



Countries: BAHAMAS, BOLIVIA, BELIZE, CANADA, CHILE, TAIWAN, COLOMBIA, COSTA RICA, DOMINICAN REPUBLIC, ECUADOR, EL SALVADOR, TRINIDAD AND TOBAGO, UNITED STATES, URUGUAY, VENEZUELA, ARUBA, NICARAGUA, PERU, PUERTO RICO, Curaçao, GUAM, GUATEMALA, GUYANA, HAITI, HONDURAS, JAMAICA, KOREA, SOUTH KOREA, PANAMA

Document ID: IK1200921

Availability: ISIS, FleetISIS

Major System: ENGINES

Current Language: English

Other Languages: NONE

Viewed: 4424

Revision: 11

Created: 6/18/2013

Last Modified: 6/8/2015

Author: Will (Mark) Wiley

[Less Info](#)

Hide Details

Coding Information

Copy Link 	Copy Relative Link 	Bookmark View My Bookmarks	Add to Favorites 	Print 	Provide Feedback 	Helpful 43	Not Helpful 6
----------------------	-------------------------------	--	-----------------------------	------------------	-----------------------------	--------------------------	-----------------------------

Title: N9 / N10 and N13 Aftertreatment Private Data Link Troubleshooting

Applies To: 2010 Navistar N13 Engine 2015 Navistar N13 Engine 2014 Navistar N9 / N10 Engine

Change Log

Dealers: Please refer to the change log text box below for recent changes to this article:

- 06/08/2015 - Updated connector composites for N13. Added private data link schematics showing backbone routing.
- 09/26/2014 - Added N9/N10 information

Description

When troubleshooting this system it's important to know the difference between PRIVATE and PUBLIC 1939 data link and how they are used with this system. The first thing to note is the DEF sending unit, NH3, both NOx sensors, SCR Temp Sensor Module are on the PRIVATE data link and **NOT** the PUBLIC 1939. Components that are on the private data link **only** will not show as a detected module when using any diagnostic tool.

- The ACM communicates on **both** the Private and the Public data link with the ECM.
- If the ACM shows up on the Helios, Intune or ServiceMaxx J1939 sniffer, then the ACM is communicating on the Public J1939.
- The ACM will show as Source Address 85
- The engine / aftertreatment private data link consists of engine and aftertreatment modules communicating to each other.
 - You cannot use a diagnostic tool to communicate with the private data link.
- Navistar engines have terminating resistors internal to the ECM and ACM
- Cummins engines have a terminating resistor internal to the VGT Actuator, and an external terminating resistor

For troubleshooting the Public data link, refer to [IK0800080 - J1939 Data Link Troubleshooting](#).

Diagnostic Trouble Codes

SPN	FMI	Description
3216	19	NOx IN not detected on J1939
4346	19	SCR Temp Sensor Module not Detected on J1939
3226	19	NOx OUT not Detected on J1939
1761	19	DEFTL not Detected on J1939
4360	19	SCR Temp Sensor Module not Detected on J1939
609	19	ACM not Detected on J1939

Service Procedure

Any Sensor or Module with 1939 faults, you must verify power/ground and ignition feeds to that component. If each passes a load test, move forward with the below 1939 circuit test at each suspect component with the complaint present.

Use the Navistar engine wiring schematic found in the [Service Portal Master Service Information](#) page for the engine you are working on. For Cummins products, use the electrical schematic book. The schematics below show the private data link only. They show the various harnesses the data link is routed through and identifies the harnesses as Navistar or Cummins harnesses.

- [N13 Private Data Link Schematic](#)
- [N9 / N10 Private Data Link Schematic](#)
- [ISX Private Data Link Schematic](#)

If the PDC cover behind the DEF Tank is removed, ensure the cover is reinstalled fully.

- 1. Check for datalink voltage + and - at each sensor or module with the key on.**
 - You should have approximately 5v total when you add the voltages from each wire together, i.e. 2.7v on one and 2.3v on the other.
 - These 2 wires should not have exactly the same voltage on them. If they do, you might have the 2 wires shorted together. Check the resistance between the 2 wires in Step 2 to be sure.
 - If you get 0v or close to it on either wire, you probably have a short to ground on that wire.
- 2. Check the resistance measuring across the + and - terminals. (Batteries must be disconnected)**
 - You should have approximately 60 ohms.
 - If you get 0 ohms, then you have a short between the 2 wires.
 - If you get 120 ohms, you have an open somewhere in the datalink or you're missing one of the resistors.
 - If you get 40 ohms, and extra terminating resistor has been added.
- 3. Check for short to ground. Check the resistance from + to ground and then – to ground. (Batteries must be disconnected)**
 - Resistance should be greater than 1,000 ohms.
 - If resistance is less than 1,000 ohms, then you have a short to ground.

Connector Composites

- The composites below were taken from an N13. Many of the connectors are used on multiple chassis. The engine sensor harness is the main difference between the different chassis types.

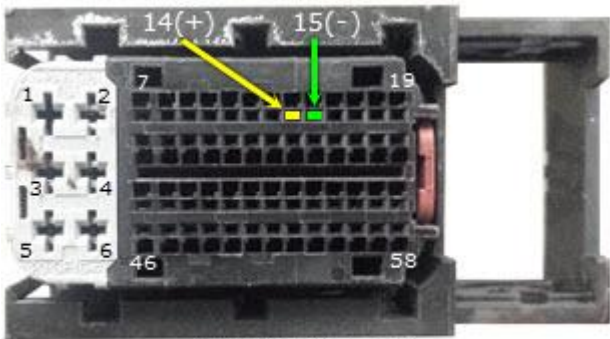
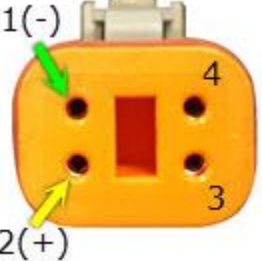
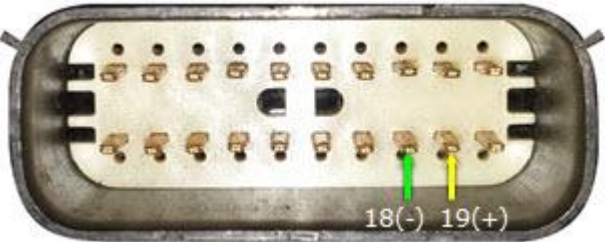
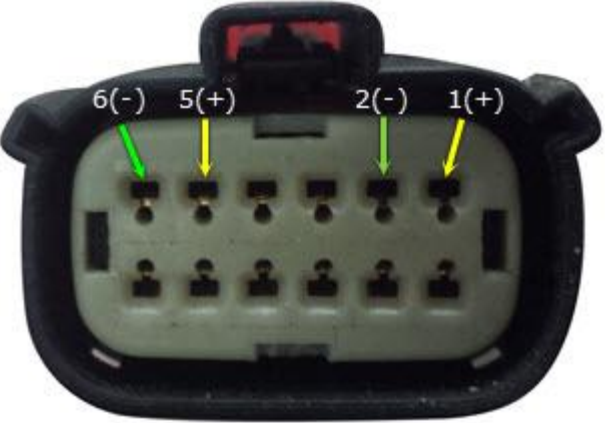

Private J1939 Data Link (CAN) Pin out for Aftertreatment System	J1939 Pins	Connector View
---	------------	----------------

(Private Data Link Only)

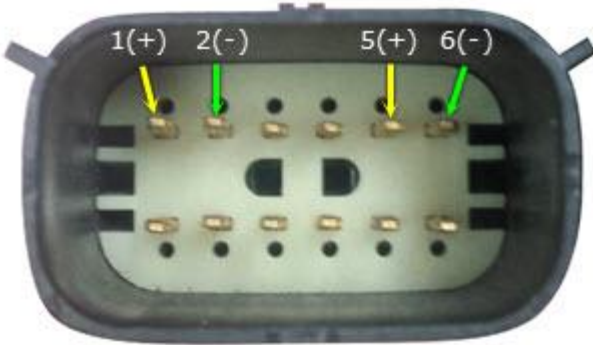
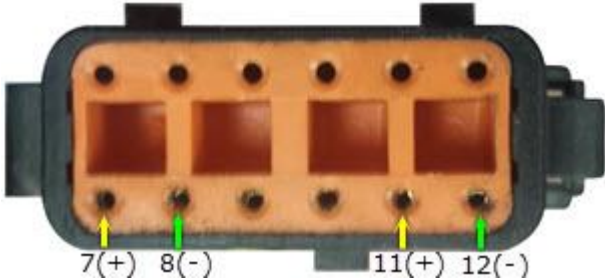
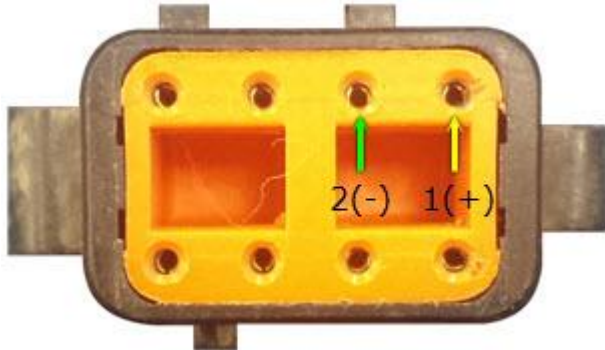
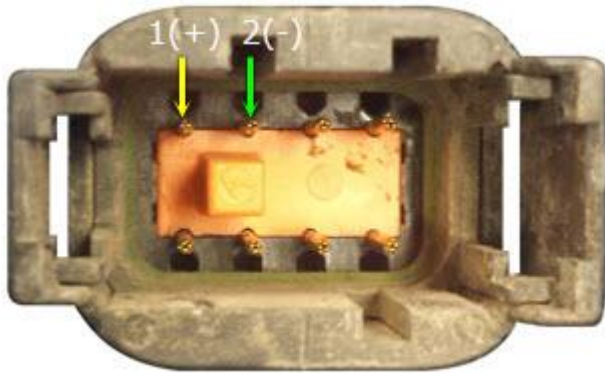
Module	Connector	Location	Pin (+)	Pin (-)	
DEF Harness Connectors *Navistar Harness					
ACM - J2	686 (58 Pin Connector)		14 (+)	15 (-)	 <p style="text-align: center;">Private Data Link</p>
DEF Tank Level / Temp	678 (4 Pin Connector)		2 (+)	1(-)	
	674 M (20 Pin Connector)		19 (+)	18 (-)	
	670 F (12 Pin Connector)		1 (+) 5 (+)	2(-) 6(-)	
AFT Jumper Harness Connectors *Navistar Harness					

	<p>670 M (12 Pin Connector)</p>		<p>1 (+)</p>	<p>2(-))</p>	
	<p>671 F (12 Pin Connector)</p>		<p>7 (+)</p>	<p>8(-))</p>	
	<p>672 F (8 Pin Connector)</p>		<p>1 (+)</p>	<p>2(-))</p>	
<p>DOC and DPF Harness Connectors *Cummins Harness</p>					
	<p>672 M (8 Pin Connector)</p>		<p>1 (+)</p>	<p>2(-))</p>	
	<p>DOC / DPF Temperature Module</p>		<p>3 (+)</p>	<p>2(-))</p>	

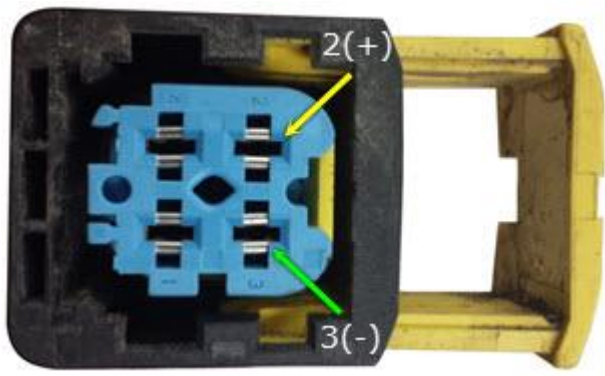
	(4 Pin Connector)				
SCR Harness Connectors *Cummins Harness					
	671 M 12 Pin Connector		7 (+) 11 (+)	8(-) 12 (-)	
	NOx Out Sensor Module 4 Pin Connector		3 (+)	2(-)	
	SCR Temperature Sensor Module 4 Pin Connector		3 (+)	2(-)	
			2 (+)	3(-)	

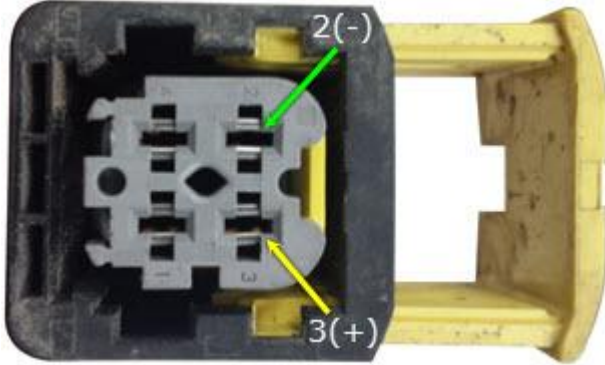
	Ammonia (NH ³) Sensor Module 4 Pin Connector				
Engine Chassis Harness *Navistar Harness					
	674 20 Pin Connector		19 (+)	18 (-)	
NOx In Sensor Module	608 4 Pin Connector		3 (+)	2 (-)	
Engine Interface	6033 21 Pin Connector		16 (+)	17 (-)	

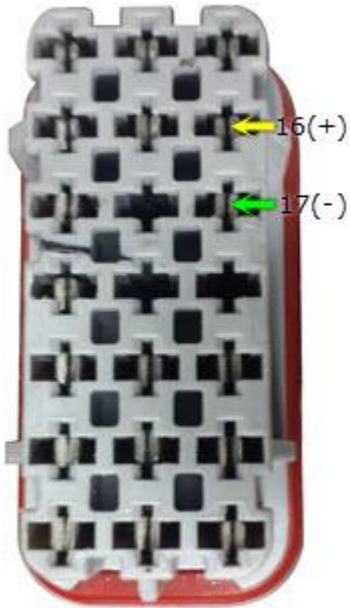
									
--	--	--	--	--	--	--	--	--	--

Engine Sensor Harness *Navistar Harness

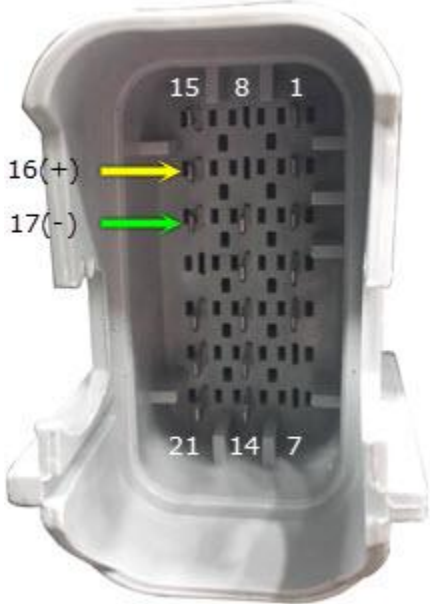
Engine Interface	6033 21 Pin Connector		16 (+)	17 (-)	
------------------	--------------------------	--	--------	--------	---

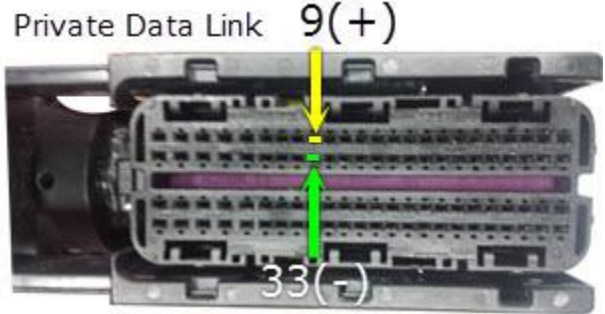
ECM - E1 N13	96 Pin Connector		E1 - 09 (+)	E1 - 33 (-)	
-----------------	------------------	--	-------------------	-------------------	--

	EGR Valve Jumper		1 (+)	2(-)	
--	------------------	--	-------	------	--

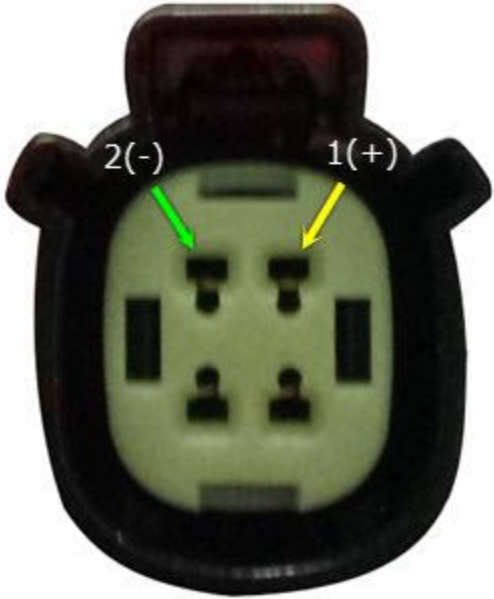
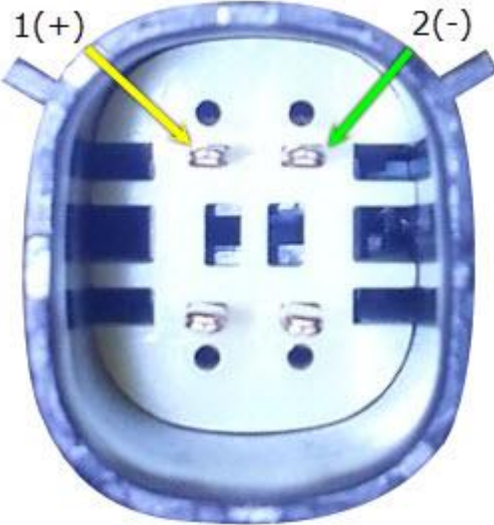
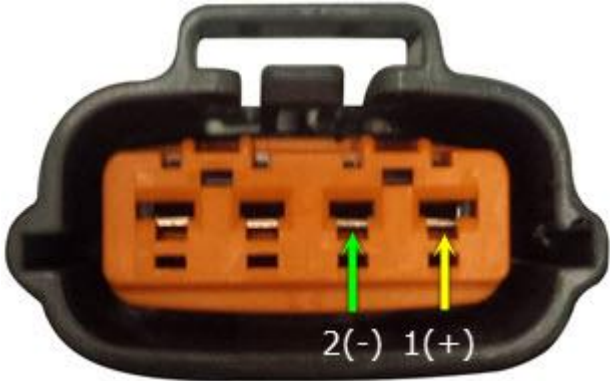
	<p>Harness 4 Pin Connector</p> <p>*2015- Newer N13 Only</p>				
<p>EGR Valve Jumper Harness *Navistar Harness</p>					
	<p>EGR Valve Jumper Harness</p> <p>4 Pin Connector</p> <p>*2015- Newer N13 Only</p>		<p>1 (+)</p>	<p>2(-)</p>	
	<p>EGR Valve 4 Pin Connector</p> <p>*2015- Newer N13 Only</p>		<p>1 (+)</p>	<p>2(-)</p>	

 Hide Details

Feedback Information

Viewed: 4423

Helpful: 43

Not Helpful: 6

No Feedback Found

Copyright © 2015 Navistar, Inc.