

PREVOST

WARRANTY BULLETIN

WB15-13

DATE :	MARCH 2015	SECTION :	16 - Suspension
EXPIRATION:	MARCH 2017		
SUBJECT :	IFS LEVEL VALVE CONTROL ROD POSSIBLE CONTACT		

Revision A This version supersedes previous versions
 June 02 2015: Added X and H vehicles.

APPLICATION

NOTICE TO SERVICE CENTERS <i>Verify vehicle eligibility by checking warranty bulletin status with SAP or via ONLINE WARRANTY SYSTEM available on Service / Warranty tab of Prevost website.</i>	
Model	VIN 
H3-45 coaches Model Year : 2012 - 2015	Vehicles with Independent Front Suspension 2PCH33495 <u>CC712019</u> ; 2PCH33494 <u>DC712272</u> ; 2PCH33499 <u>EC712544</u> 2PCH33495 <u>EC712556</u> ; 2PCH33499 <u>EC712558</u>
X3-45 coaches Model Year : 2012 - 2015	Vehicles with Independent Front Suspension 2PCG33499 <u>CC735170</u> ; 2PCG33490 <u>CC735171</u> ; 2PCG33496 <u>CC735241</u> 2PCG33498 <u>CC735242</u> ; 2PCG33491 <u>CC735275</u> ; 2PCG33493 <u>CC735276</u> 2PCG3349X <u>CC735291</u> ; 2PCG33490 <u>DC735382</u> ; 2PCG33492 <u>DC735383</u> 2PCG3349X <u>DC735387</u> ; 2PCG33491 <u>DC735388</u> ; 2PCG3349X <u>DC735390</u> 2PCG33491 <u>DC735391</u> ; 2PCG33493 <u>DC735392</u> ; 2PCG33495 <u>DC735393</u> 2PCG33497 <u>DC735444</u> ; 2PCG33496 <u>DC735449</u> ; 2PCG33493 <u>EC735586</u> 2PCG33497 <u>EC735588</u> ; 2PCG33497 <u>EC735591</u> ; 2PCG33494 <u>EC735659</u> 2PCG33492 <u>EC735661</u> ; 2PCG33494 <u>EC735662</u> ; 2PCG33498 <u>EC735664</u> 2PCG33493 <u>FC735797</u> ; 2PCG3349X <u>FC735814</u> ; 2PCG33491 <u>FC735815</u> 2PCG33495 <u>FC735817</u> .
This bulletin does not necessarily apply to all the above-mentioned vehicles, some vehicles may have been modified before delivery. The owners of the vehicles affected by this bulletin will be advised by a letter indicating the Vehicle Identification Number (VIN) of each vehicle concerned.	

DESCRIPTION

On the independent front suspension level valve linkage of the vehicles affected by this bulletin, a control rod may come in contact with an air reservoir outlet when vehicle rises from Low to High Buoy. As a result, the vehicle may be leveled higher in "Normal" position.

The interference is corrected by changing the side on which the rod is attached to the linkage.

MATERIAL

No parts are required for this bulletin.

PROCEDURE



DANGER

Park vehicle safely, apply parking brake, stop engine and set battery master switch(es) to the OFF position prior to working on the vehicle.

1. On the front axle, locate the front suspension sway bar. (Fig. 1)

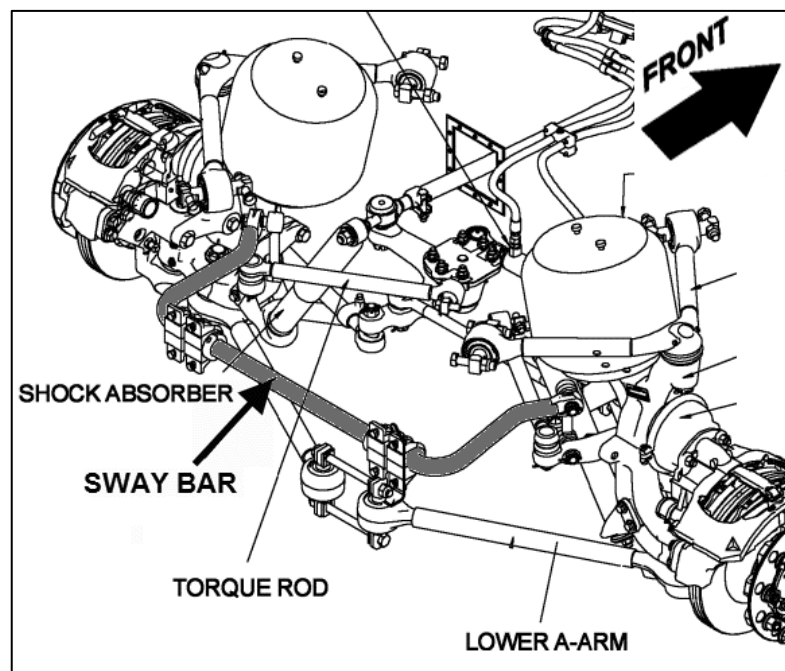

Figure 1

2. In the middle of the sway bar you will find a bracket clamped on the tube. The bracket supports two control rods (Fig. 2)

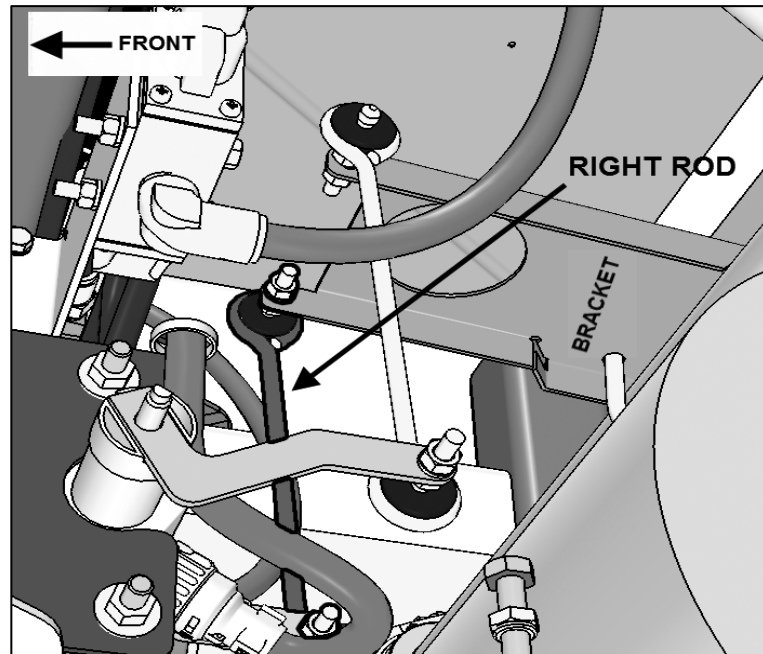

Figure 2

3. On the right hand side rod. (Fig.2) Unscrew the upper and lower mounting nuts.
4. Flip the rod over to the opposite side of the control lever and bracket tab above. (Arrow, Fig. 3)
5. Re-assemble hardware. (Fig.3)

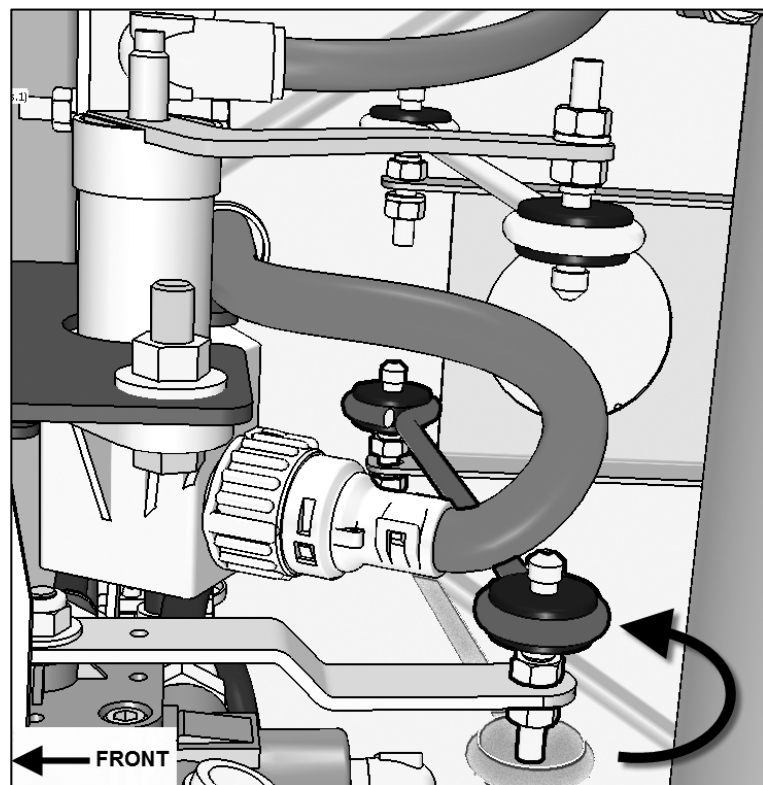

Figure 3 : Flip upper and lower connection of control rod.

6. Adjust ride height to 12 7/8" ±1/4". (328mm ±6mm)

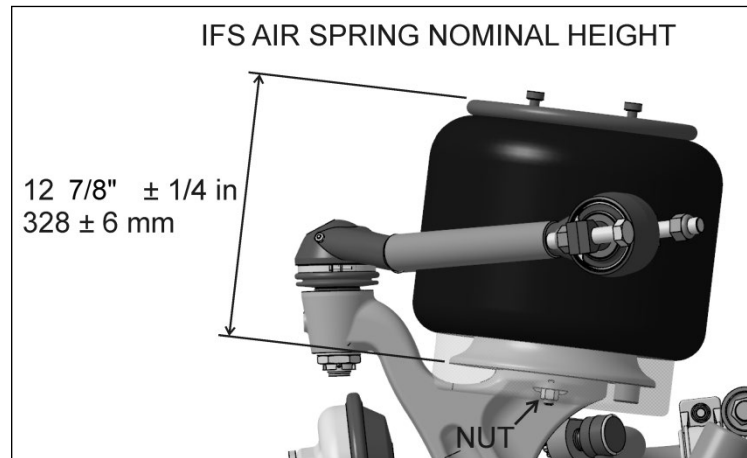

Figure 4

PARTS / WASTE DISPOSAL

DO NOT RETURN THE REPLACED PARTS. Discard waste according to applicable environmental regulations (Municipal/State[Prov.]/ Federal)

WARRANTY

This modification is covered by Prevo's normal warranty. We will reimburse you forty-five minutes (45min) of labor upon receipt of a warranty claim. Please submit claim via our Online Warranty System, available at www.prevo.com (under Service \ Warranty section). Use Claim Type: "Bulletin/Recall" and select "Warranty Bulletin WB15-13".

OTHER

VBC Bulletin	N/A
Fail Code	16.05
Defect Code	09
Syst.Cond.	B
Causal Part	131609

Access all our Service Bulletins on <https://secureus5.volvo.com/technicalpublications/en/pub.asp> or scan the QR-Code with your smart phone.

E-mail us at technicalpublications_prev@volvo.com and type "ADD" in the subject to receive our warranty bulletins by e-mail.

