



Service Bulletin

SPECIAL COVERAGE

SUBJECT: Special Coverage Adjustment – Rear Fascia Heat Distortion or Hole from License Plate Lamps

MODELS: 2010-2013 Chevrolet Camaro
Without Rear Tow Hooks (RPO VJR)

CONDITION

On some 2010-2013 model year Chevrolet Camaro vehicles, the license-plate lamp housing-retention features could fracture off the housing. If this occurs, the bulb socket could move out of its original-design location, which could cause an illuminated bulb to touch and melt the lamp housing and the adjacent rear bumper fascia cover. The hot rear bumper fascia cover, or the hot bulb itself, depending on the severity of the melting, could come into contact with someone who is loading or unloading the trunk.

SPECIAL COVERAGE ADJUSTMENT

This special coverage covers the condition described above for a period of 10 years or 120,000 miles (193,000 km), whichever occurs first, from the date the vehicle was originally placed in service, regardless of ownership.

Dealers are to replace the current license plate lamp housings with a new housing and repair any damage to the rear fascia. The repairs will be made at no charge to the customer.

For vehicles covered by Vehicle Service Contracts, all eligible claims with repair orders on or after September 21, 2015, are covered by this special coverage and must be submitted using the labor operation codes provided with this bulletin. Claims with repair orders prior to September 21, 2015, must be submitted to the Service Contract provider.

VEHICLES INVOLVED

All involved vehicles are identified by Vehicle Identification Number on the Applicable Warranties section in GM Global Warranty Management system. Dealership service personnel should always check this site to confirm vehicle involvement prior to beginning any required inspections and/or repairs. It is important to routinely use this tool to verify eligibility because not all similar vehicles may be involved regardless of description or option content.

PART INFORMATION

Parts required to complete this program are to be obtained from General Motors Customer Care and Aftersales (GMCC&A). Please refer to your “involved vehicles listing” before ordering parts. Normal orders should be placed on a DRO = Daily Replenishment Order. In an emergency situation, parts should be ordered on a CSO = Customer Special Order.

Part Number	Description	Quantity/Vehicle
23388071	*Lamp, Rear License Plate	2
13500812	Bulb	2

* This lamp comes with a new rubber seal. Ensure the new seal is installed on the bulb socket.

SERVICE PROCEDURE

Use the following steps to replace the two rear license lamp housings and bulbs. If the rear bumper fascia is damaged (localized dimple caused by license lamp bulb) refer to the **Rear Fascia Repair** section of this bulletin.

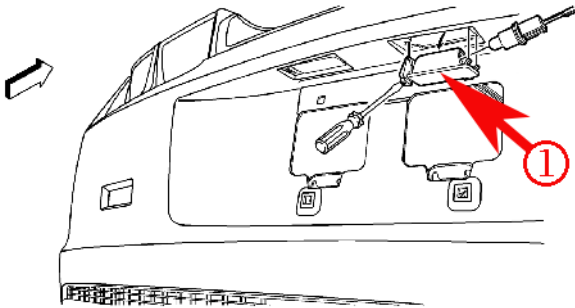

4178909

Note: Before reinstalling the bulb sockets into the license lamp housings, remove the existing O-ring seals on the bulb sockets and replace them with the new O-ring seals contained in the container for 23388071.

Replace the two rear license lamp housings (1) and bulbs. Refer to *Rear License Plate Lamp Replacement* in SI.

Rear Fascia Repair

1. Remove the rear bumper fascia. Refer to *Rear Bumper Fascia Replacement* in SI.

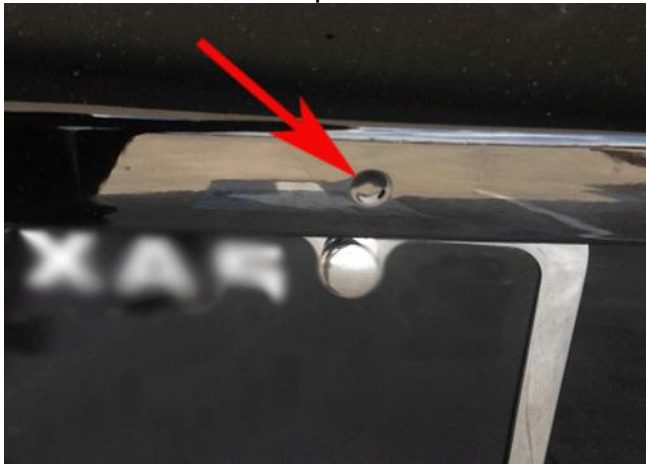

4178911

2. Using standard flexible part repair procedure, repair the affected area of the fascia.
3. *Refinish as required.
4. Reinstall the bumper fascia. Refer to *Rear Bumper Fascia Replacement* in SI.

* Refer to the 2014 GM Approved Refinish Materials booklet (GMW-15406) for specific products. To access the booklet, go to www.genuinegmparts.com. Click on Collision Repair. From this page, Click on Paint Shop. Select 2014 GM Approved Refinish Materials. In Canada, the GM Approved Refinish Materials Booklet is also available in GM GlobalConnect by choosing LIBRARY, SERVICE and then PAINT SHOP.

CUSTOMER REIMBURSEMENT - For US

Customer requests for reimbursement of previously paid repairs to correct the condition described in this bulletin are to be submitted to the dealer by October 31, 2016, unless otherwise specified by state law. If this is not convenient for the customer, the customer may mail the completed Customer Reimbursement Request Form and all required documents to the GM Customer Assistance Center. Repairs must have occurred within the 10 years of the date the vehicle was originally placed in service, or 120,000 miles, whichever occurs first.

All reasonable and customary costs to correct the condition described in this bulletin should be considered for reimbursement. Any questions or concerns should be reviewed with your GM representative prior to processing the request.

When a customer requests reimbursement, they must provide the following:

- A completed Customer Reimbursement Request Form. This form is mailed to the customer or can be obtained through GM GlobalConnect.
- The name and address of the person who paid for the repair.
- Paid receipt confirming the amount of the repair expense, a description of the repair, and the person or entity performing the repair.

IMPORTANT: GM requires dealers to approve or deny a reimbursement request within 30 days of receipt. If a reimbursement request is approved, the dealer should immediately issue a check to the customer and submit an appropriate warranty transaction for the incurred expense. If a

reimbursement request is denied, the dealer MUST provide the customer with a clear and concise explanation, in writing, as to why the request was denied. The bottom portion of the Customer Reimbursement Request Form may be used for this purpose. If the denial was due to missing documents, the customer can resubmit the request when the missing documents are obtained, as long as it is still within the allowed reimbursement period.

Warranty transactions for customer reimbursement of previously paid repairs are to be submitted as required by GM Global Warranty Management. Additional information can also be found in Warranty Administration Bulletin 11-00-89-004.

CUSTOMER REIMBURSEMENT - For Canada and Export

Customer requests for reimbursement of previously paid repairs to correct the condition described in this bulletin are to be submitted to the dealer prior to or by October 31, 2016. Repairs must have occurred within the 10 years of the date the vehicle was originally placed in service, or 193,000 kilometers, whichever occurs first.

When a customer requests reimbursement, they must provide the following:

- Proof of ownership at time of repair.
- Original paid receipt confirming the amount of unreimbursed repair expense(s) (including Service Contract deductibles), a description of the repair, and the person or entity performing the repair.

All reasonable and customary costs to correct the condition described in this bulletin should be considered for reimbursement. Any questions or concerns should be reviewed with your GM representative prior to processing the request.

COURTESY TRANSPORTATION – For US and Canada

The General Motors Courtesy Transportation program is intended to minimize customer inconvenience when a vehicle requires a repair that is covered by the New Vehicle Limited Warranties. The availability of courtesy transportation to customers whose vehicles are within the warranty coverage period and involved in a product program is very important in maintaining customer satisfaction. Dealers are to ensure that these customers understand that shuttle service or some other form of courtesy transportation is available and will be provided at no charge. Dealers should refer to the General Motors Service Policies and Procedures Manual for Courtesy Transportation guidelines.

WARRANTY TRANSACTION INFORMATION

Submit a transaction using the table below. All transactions should be submitted as a ZREG transaction type, unless noted otherwise.

For Use With Vehicles <u>Still Covered</u> Under Applicable New Vehicle Limited Warranties			
Labor Code	Description	Labor Time	Net Item
2041760	Rear License Plate Lamp Replacement (Use With Vehicles Covered Under Warranty That Do Not Require Fascia Repair)	0.2	N/A

Note: For reimbursements on vehicles covered under warranty, refer to the Policies and Procedures Manual.

For Use With Vehicles <u>No Longer Covered</u> Under Applicable New Vehicle Limited Warranties			
Labor Code	Description	Labor Time	Net Item
9900168	Rear License Plate Lamp Replacement	0.2	N/A
9900169	*Rear License Plate Lamp Replacement Including Fascia Repair	3.8	N/A
9900170	Customer Reimbursement Approved	0.2	**
9900171	Customer Reimbursement Denied - For US dealers only	0.1	N/A

Note: To avoid having to "H" route the customer reimbursement transaction for approval, it must be submitted prior to the repair transaction.

- * This repair includes repair of the localized melted area of the fascia, prime, block, color coat repair area and clear coat the complete fascia. Paint and Mix time is also included in this time. The amount identified in Net Item should reflect the actual cost of the paint and material allowance (AR).
- ** The amount identified in "Net Item" should represent the dollar amount reimbursed to the customer.

CUSTOMER NOTIFICATION

General Motors will notify customers of this special coverage on their vehicles (see copy of typical customer letter included with this bulletin - actual divisional letter may vary slightly).



October 2015

This notice applies to your vehicle, **VIN:** _____

Dear General Motors Customer:

As the owner of a 2010-2013 model year Chevrolet Camaro your satisfaction with our product is very important to us.

This letter is intended to make you aware that on some 2010-2013 model year Chevrolet Camaro vehicles, the license-plate lamp housing-retention features could fracture off the housing. If this occurs, the bulb socket could move out of its original-design location, which could cause an illuminated bulb to touch and melt the lamp housing and the adjacent rear bumper fascia cover. The hot rear bumper fascia cover, or the hot bulb itself, depending on the severity of the melting, could come into contact with someone who is loading or unloading the trunk.

Do not take your vehicle to your GM dealer as a result of this letter unless you believe that your vehicle has the condition as described above.

What We Have Done: General Motors is providing owners with additional protection for the condition described above. If this condition occurs on your 2010-2013 model year Camaro within 10 years of the date your vehicle was originally placed in service or 120,000 miles (160,000 km), whichever occurs first, the condition will be repaired for you at **no charge**. Diagnosis or repair for conditions other than the condition described above is not covered under this special coverage program.

What You Should Do: If you believe that your vehicle has the condition described above, repairs and adjustments qualifying under this special coverage must be performed by a General Motors dealer. You may want to contact your GM dealer to find out how long they will need to have your vehicle so that you may schedule the appointment at a time that is convenient for you. This will also allow your dealer to order parts if they are not already in stock. Keep this letter with your other important glove box literature for future reference.

Reimbursement: If you have paid for repairs for the condition described in this letter, please complete the enclosed reimbursement form and present it to your dealer with all required documents. Working with your dealer will expedite your request, however, if this is not convenient, you may mail the completed reimbursement form and all required documents to Reimbursement Department, PO Box 33170, Detroit, MI 48232-5170. The completed form and required documents must be presented to your dealer or received by the Reimbursement Department by October 31, 2016, unless state law specifies a longer reimbursement period.

If you have any questions or need any assistance, just contact your dealer or the appropriate Customer Assistance Center at the number listed below.

Division	Number	Text Telephones (TTY)
Chevrolet	1-800-222-1020	1-800-833-2438
Guam	65-6267-1752	
Puerto Rico – English	1-800-496-9992	
Puerto Rico – Español	1-800-496-9993	
Virgin Islands	1-800-496-9994	

We are sorry for any inconvenience you may experience; however, we have taken this action in the interest of your continued satisfaction with our products.

Alicia S. Boler-Davis
Sr. Vice President
Global Connected Customer Experience

Enclosure
15030

GM CUSTOMER CARE AND AFTERSALES
DCS3780
URGENT - DISTRIBUTE IMMEDIATELY

Date: September 21, 2015

Subject: 15030 – Special Coverage Adjustment
Rear Fascia Heat Distortion or Hole from License Plate Lamps

Models: 2010-2013 Chevrolet Camaro
Without Rear Tow Hooks (RPO VJR)

To: All Chevrolet Dealers

Attention: General Manager, Service Advisor, Service Manager, Parts and
Service Director, Parts Manager, Used Vehicle Sales Manager,
and Warranty Administrator

General Motors is releasing Special Coverage Adjustment 15030 today. The total number of U.S. vehicles involved is approximately 381,787. Please see the attached bulletin for details.

Customer Letter Mailing

The customer letter mailing will begin in Mid-October, 2015.

Global Connect (GWM)

The "Investigate Vehicle History" (IVH) screen will be updated September 22, 2015.

Campaign Initiation Detail Report (CIDR)

The CIDR is not available for Special Coverage Adjustments.

END OF MESSAGE
GM CUSTOMER CARE AND AFTERSALES