

# Technical Bulletin

Model(s)	Year	Eng. Code	Trans. Code	VIN Range From	VIN Range To
Jetta, Jetta Wagon	2009	2.0L TDI (CBEA)	All	All	All
Golf, Jetta, Jetta SportWagen	2010-2013	2.0L TDI (CJAA)	All	All	All
Passat	2012-2013	2.0L TDI (CKRA)	All	All	All
Touareg	2009-2010	3.0L TDI (CKRA)	All	All	All
Touareg	2011-2013	3.0L TDI (CNRB)	All	All	All
Beetle	2013	2.0L TDI (CJAA)	All	All	All

## Condition

01 15 18 July 20, 2015 2023591 Supersedes T. B. V011231 dated October 24, 2012 to add additional text about readiness codes on UDS vehicles.

### TDI Clean Diesel I/M (Inspection Maintenance) Testing Issues due to Readiness Not Set

DTCs were recently erased from the vehicle's engine control module (ECM).

A Volkswagen TDI clean diesel is not ready for I/M (Inspection Maintenance) testing due to readiness codes not being fully set.

#### Tip:

This does not indicate any technical problems with the vehicle, only that more driving may be necessary to set full OBD readiness.

Certain environmental conditions and customer driver profiles may extend the drive time required to fully set readiness on TDI clean diesel vehicles. Fully setting the DPF monitoring function requires a cycle of building soot and burning the soot off during a regeneration process.

#### Tip:

If possible, advise customer not to service vehicle directly before I/M inspection. If the readiness bits are reset, this can create a condition where extensive driving is required prior to setting full readiness.

# Technical Bulletin

## Technical Background

Some readiness codes on TDI clean diesel vehicles require special driving conditions to be set. If DTCs have been recently erased from the vehicle's ECM, it may take additional driving under different conditions to fully set OBD readiness parameters.

MVB 89 (on non-UDS protocol ECM's) will store correct data concerning OBD readiness. Figure 1 illustrates how to manually read OBD readiness codes.

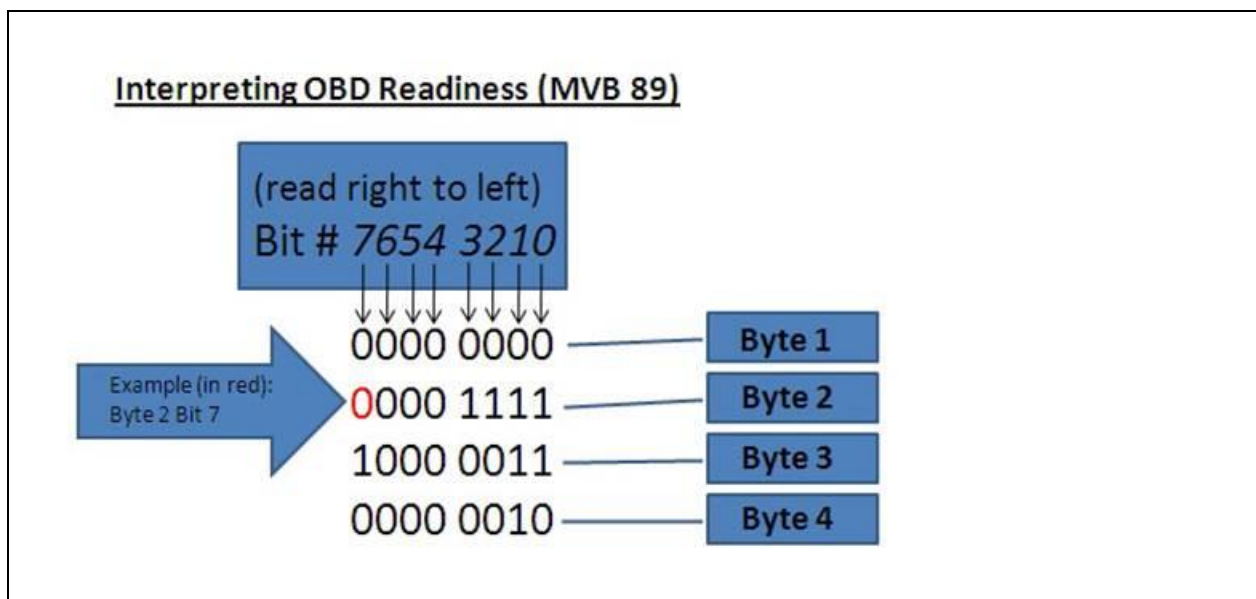

**Figure 1.** An example of a possible MVB 89 reading. Actual values will depend on vehicle tested and OBD readiness status.

**Tip:**

To check readiness code status, verify ODIS is at the latest software level and utilize the following:

From the control module list view, right click on the ECM and select Vehicle OBD. Then select OBD customer service. Left click on Mode 01: "Check current diagnostic data. PID 01".

Click on each individual selection to verify status.

# Technical Bulletin

**Additional Information:**

**Interpreting Bit Values:**

MVB89 is displayed as an 8-bit value. Depending on which diagnostic tester is used, the measurement value may be displayed as follows: „1010 0100“. All positions in the measurement value are described in bits, where Bit0 is the rightmost position and Bit7 is the leftmost position.

**Example:**

MVB89/4 = 1000 0011

- Bit0 1 Test NMHC catalyst monitoring (1 = not complete; 0 = complete)
- Bit1 1 Test NOx/SCR aftertreatment monitoring (1 = not complete; 0 = complete)
- Bit2 0 optional
- Bit3 0 Test Boost pressure system monitoring (1 = not complete; 0 = complete)
- Bit4 0 optional
- Bit5 0 Test Exhaust gas sensor monitoring (1 = not complete; 0 = complete)
- Bit6 0 Test PM filter monitoring (1 = not complete; 0 = complete)
- Bit7 1 Test EGR system monitoring (1 = not complete; 0 = complete)

MVB 89 (EOBD Status 1)

MVB 89/1	MVB 89/2	MVB 89/3	MVB 89/4
Monitor status since DTCs cleared DATA A	Monitor Status since DTCs cleared DATA B	Monitor Status since DTCs cleared DATA C	Monitor Status since DTCs cleared DATA D

**" MVB 89/1" Describes whether DTCs are stored and how many**

- \_000 XXXX # of DTCs stored in this ECU
- X000 0001 1 DTCs stored
- X000 0010 2 DTCs stored
- X000 0011 3 DTCs stored
- .....
- X000 1000 8 DTCs stored
- 0XXX XXXX MIL-Lampe off
- 1XXX XXXX MIL-Lampe on

# Technical Bulletin

---

## **"MVB 89/2" Describes which functions are supported and the fuel type**

- Bit0 Support: Misfire monitoring (1 = supported; 0 = not supported)
- Bit1 Support: Fuel system monitoring (1 = supported; 0 = not supported)
- Bit2 Support: Comprehensive component monitoring (1 = supported; 0 = not supported)
- Bit3 Compression ignition monitoring = Diesel
- Bit4 Test Misfire monitoring (1 = not complete; 0 = complete)
- Bit5 Test Fuel system monitoring (1 = not complete; 0 = complete)
- Bit6 Test Comprehensive component monitoring (1 = not complete; 0 = complete)
- Bit7 optional

## **" MVB 89/3" Describes which monitors are supported on this vehicle**

- Bit0 Support: NMHC catalyst monitoring (1 = supported; 0 = not supported)
- Bit1 Support: NOx/SCR after-treatment monitoring (1 = supported; 0 = not supported)
- Bit2 optional
- Bit3 Support: Boost pressure system monitoring (1 = supported; 0 = not supported)
- Bit4 optional
- Bit5 Support: Exhaust gas sensor monitoring (1 = supported; 0 = not supported)
- Bit6 Support: PM filter monitoring (1 = supported; 0 = not supported)
- Bit7 Support: EGR system monitoring (1 = supported; 0 = not supported)

## **" MVB 89/4" provides the readiness status of the SUPPORTED systems from MVB 89/3**

- Bit0 Test NMHC catalyst monitoring (1 = not complete; 0 = complete)
- Bit1 Test NOx/SCR after-treatment monitoring (1 = not complete; 0 = complete)
- Bit2 optional
- Bit3 Test Boost pressure system monitoring (1 = not complete; 0 = complete)
- Bit4 optional
- Bit5 Test Exhaust gas sensor monitoring (1 = not complete; 0 = complete)
- Bit6 Test PM filter monitoring (1 = not complete; 0 = complete)
- Bit7 Test EGR system monitoring (1 = not complete; 0 = complete)

# Technical Bulletin

---

## Production Solution

No Production Solution required.

## Service

1. To check the correct status of OBD readiness, refer to MVB 89 and the supplemental information in the *Technical Background* section (applies to non-UDS protocol vehicles). For ECMs with UDS protocol, readiness status can be obtained by reading the Mode 1 – Mode 10 data within the OBD section of the scan tool.
2. If any OBD system indicates incomplete monitoring (“1” shown in Byte 4) with no DTCs stored in the ECM, no repair is necessary.

### Tip:

There is no need to repair any vehicle system due to readiness not being set. Repair work is required *only* if there is a relevant DTC stored within the ECM and the MIL is illuminated. Ignore pending DTCs.

### Tip:

Do *not* reset the ECM unless a DTC is saved in memory and the MIL is illuminated. Ignore pending DTCs. Resetting the ECM will erase the readiness codes and additional driving will be required to set the readiness codes.

3. The vehicle requires additional driving to complete the OBD readiness checks. Drive the vehicle until all required monitoring systems indicate complete readiness before attempting emissions testing. Do not send a customer to I/M testing until the readiness meets the minimum state requirements.
4. Contact the VW Technical Helpline (TAC) if there are difficulties setting readiness on a TDI clean diesel vehicle.

### Procedure:

#### Required conditions for running this procedure:

Switch OFF accessories (ex. Heated seats, rear defroster, climate control, lights, etc.).

No fault entries recorded in the Engine Control Module (ECM).

Driving profile requires approximately 60-90 minutes.

#### General procedure in order to achieve “Readiness” (diagnostic checks complete)

The engine should be running (leave ignition key “on) during the entire procedure so that the driving profile is not extended unnecessarily.

Some of the bits described in the table may be set by driving the vehicle a certain way. In this case, the corresponding test procedure steps can be skipped.

# Technical Bulletin

## Procedure for Diesel Particulate Filter (DPF) Regeneration

Only one DPF regeneration is necessary per driving cycle. This means, if points 1-7 need to be carried out, only one DPF regeneration is required.

### In order to carry out regeneration:

Start adaptation channel 13 (DPF service regeneration) with security access. The DPF light switches ON and stays ON for the entire time during regeneration. If the light switches OFF, then the regeneration process is completed.

During regeneration, the vehicle needs to be driven at constant speed (50-70 mph or 80-120 km/h), preferably using cruise control over a stretch of highway or country road. Periods of vehicle acceleration or coasting should be avoided.

 **Note:**

Obey all local and state traffic laws.

### Description of Table 2

The column “**NO.**” shows an optimal sequence for conducting the readiness vehicle profile split into individual “readiness categories”. The “**Number**” stands for a particular “readiness category”, and the “**Letter**” stands for a “subcategory” which needs to be set in order to test the “readiness category”.

The column “**MVB 89 Ok = 0**” describes the “readiness category”. This bit = 0 when this category has achieved readiness. The “subcategories” belonging to this “readiness category” no longer need to be carried out.

The column “**MVB 86 Ok = 1**” describes the readiness “subcategory”. This bit = 1 after the “category” has been tested. The “subcategories” no longer need to be tested when the “readiness category” bit for the particular “subcategory” has already been set.

The column “procedure” describes the required vehicle profile which is necessary to set the bits in the “readiness category” or in the “subcategory”.

**Table 1: Description of Readiness categories**

No.	PiD01 readiness categories <b>since</b> SAE-J1979 (mai 2007 (new))	PiD01 readiness description <b>before</b> SAE-J1979 (mai 2007)
1.	Misfiring monitoring	Misfire monitoring
2.	PM filter monitoring	Oxygen sensor heater monitoring
3.	EGR system monitoring	EGR system monitoring
4.	NMHC catalyst monitoring	Catalyst monitoring

# Technical Bulletin

5.	NOx/SCR after-treatment monitoring	Heated catalyst monitoring
6.	Exhaust gas sensor monitoring	Oxygen sensor monitoring
7.	Boost pressure system monitoring	Secondary air system monitoring

**Table 2: Readiness-Bits and Driving Procedure**

NO.	MVB 89 Ok = 0	MVB 86 Ok = 1	Procedure
1a	89/2 Bit 4	-	Monitor must be restarted and idle for 45 seconds
2a	89/4 Bit 6	86/2 Bit 7	Drive for 30 minimum 30 sec. at 3000 rpm in 4 <sup>th</sup> -5 <sup>th</sup> gear
2a	89/4 Bit 6	86/2 Bit 6	Drive for 30 minimum 30 sec. at 3000 rpm in 4 <sup>th</sup> -5 <sup>th</sup> gear. Additionally "A total of" roughly 140 sec. dynamic driving (coasting/acceleration transmissions), Gas pedal position at max. 50%, (vehicle profile interruptions are allowed).
2b	89/4 Bit 6	86/2 Bit 4	DPF regeneration <sup>1</sup> and drive: The vehicle must be driven for 5 min. at a constant speed (50-70 mph, 80-120 km/h), preferably using cruise control over a stretch of highway or country road. Phases of acceleration or coasting are to be avoided in order to set MVB 86/2 Bit 4.
2b	89/4 Bit 6	86/2 Bit 5	DPF regeneration <sup>1</sup> and drive: When MVB 100/1 > 575°C (1073°F) (EGT3, drive for 150 additional seconds then, if possible, immediately pull over, stop, and let the vehicle idle for 60 sec. until MVB 86/2 Bit5 is set. Finally, continue with regeneration.
2c	89/4 Bit 6	-	DPF regeneration <sup>1</sup> until the light goes out.
3a	89/4 Bit 0	-	DPF regeneration <sup>1</sup> until the light goes out.
4a	89/4 Bit 7	86/1 Bit 7	MVB 100/2 > 300°C (573°F). Maintain this condition for about 60 sec. (avoid coasting).
4b	89/4 Bit 7	86/1 Bit 3	Drive at constant speed for 20 sec. in 3 <sup>rd</sup> gear at 1800 rpm.
4c	89/4 Bit 7	86/1 Bit 6	Coast for 8 sec. when motor is warm.

# Technical Bulletin

5a	89/4 Bit 1	-	Drive 30-40 min. at constant speed, (50-70 mph, 80-120 km/h), in 5-6 <sup>th</sup> gear.
6a	89/4 Bit 5	86/3 Bit 0	Test run in order to warm up exhaust system
6a	89/4 Bit 5	86/3 Bit 1	Test run in order to warm up exhaust system (2 min. no coasting)
6a	89/4 Bit 5	86/4 Bit 0	Test run in order to warm up exhaust system
6a	89/4 Bit 5	86/4 Bit 1	Test run in order to warm up exhaust system (2 min. no coasting)
6b	89/4 Bit 5	86/3 Bit 4	Leave vehicle idling for 30 sec.
6b	89/4 Bit 5	86/4 Bit 4	Leave vehicle idling for 30 sec.
6c	89/4 Bit 5	86/3 Bit 2	Moderate acceleration up to 2500 rpm, then quickly release gas pedal.
6c	89/4 Bit 5	86/4 Bit 2	Moderate acceleration up to 2500 rpm, then quickly release gas pedal.
6d	89/4 Bit 5	86/3 Bit 3	Coasting phase at 3000 rpm in 4 <sup>th</sup> gear (min. 10 sec.)
6d	89/4 Bit 5	86/4 Bit 3	Coasting phase at 3000 rpm in 4 <sup>th</sup> gear (min. 10 sec.)
6e	89/4 Bit 5	86/3 Bit 5	Drive 30-45 min, at constant speed, (50-70 mph, 80-120 km/h), in 5-6 <sup>th</sup> gear.
6e	89/4 Bit 5	86/4 Bit 5	Drive 30-45 min, at constant speed, (50-70 mph, 80-120 km/h), in 5-6 <sup>th</sup> gear.
7a	89/4 Bit 3	-	Drive 30-45 min, at constant speed, (50-70 mph, 80-120 km/h), in 5-6 <sup>th</sup> gear.
<sup>1</sup> = carry out DPF regeneration. See part 3: Procedure for DPF Regeneration			

**Note:**

During winter conditions, the setting of the readiness flag for Nox after-treatment MVB 89/4 Bit 1 will be delayed. In this case, the vehicle must be driven for a much longer period.





# Technical Bulletin

---

## Warranty

Information Only.

## Required Parts and Tools

No Special Parts required.

Tool Description	Tool No:
Midtronics Battery Tester/Charger	InCharge 940 (INC-940)
VAS Diagnostic Tool	VAS 6150/X & VAS 6160/X with ODIS Service with: current online updates

## Additional Information

All part and service references provided in this Technical Bulletin are subject to change and/or removal. Always check with your Parts Dept. and Repair Manuals for the latest information.