



Technical Bulletin

Model(s)	Year(s)	Eng. Code(s)	Trans. Code(s)	VIN Range From	VIN Range To
Jetta	2013	All	All	All	All
Jetta Hall 84	2014	All	All	AJ_EM350000	AJ_EM426630
Jetta Hall 04	2014	All	All	AJ_EM200001	AJ_EM282126

Condition

87 15 02 March 5, 2015 **2037255** Supersedes Technical Bulletin V871406 dated June 19, 2014 to update air distribution box production date.

Whistle Noise from Center Vent Area; Blower Set On 3 or 4 with Full Heat Selected

Technical Background

Customer may hear a high pitched whistle when the Climatic temperature knob is on full heat and the blower is set to either 3 or 4. The temperature flaps allow air to escape past the temperature flap seal.

Production Solution

Introduction of improved air distribution unit CW13/14.

Technical Bulletin

Service

Install temperature flap lever kit

! Note:

Vehicles built before 9/30/2013: Install both left and right levers.

Vehicles built after 9/30/2013: Inspect the air distribution unit production date.



Figure 1

- Remove the radio, see Repair Group 91 in Elsa.
- The label on the air distribution unit is located on the front of the distribution unit assembly (Figure 1).
- Check the production date of the air distribution unit (Figure 2).

! Note:

The production date is Day/Month/Year (120913 = Sep 12th 2013) (Figure 2).

All air distribution units built before 9/30/2013 will require both the left and the right temperature flap levers.

Air distribution boxes built between **October 1st 2013 and **March 20th 2014** will require only the right (Black) temperature flap lever.**



Figure 2

Technical Bulletin

Repair Procedure Left Side Air Distribution Unit



Installation of driver side temperature flap lever (White).

 **Note:**

Set the temperature to full cold position to set the temperature flaps. This will aid in the installation.



- Locate the left temperature flap lever (White) on the distribution housing (Figure 3).

Figure 3

Technical Bulletin



Figure 4

- Using the needle-nose pliers remove the cam lever linkage. (Figure 4).

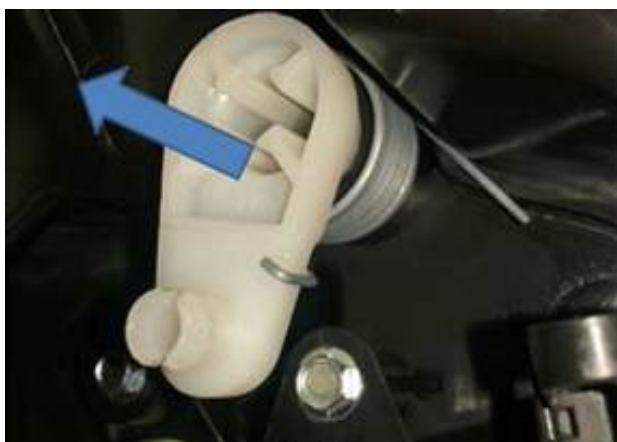

Figure 5

- Firmly pull the temperature flap lever for distribution housing driver side (White Lever) to detach it (Figure 5).

Technical Bulletin



- Remove the left temperature flap lever and replace it with the new white lever and firmly insert it in the same position.
- Compress the spring and ensure that spring is placed in the correct position (Figure 6).



Figure 6



- Assemble the plastic cam lever link back on the temperature flap lever (Figure 7).
- Verify the correct function of air conditioning temperature control.

Figure 7

Technical Bulletin

Repair Procedure Right Side Air Distribution Unit



Installation of the passenger side temperature flap lever. (Black)

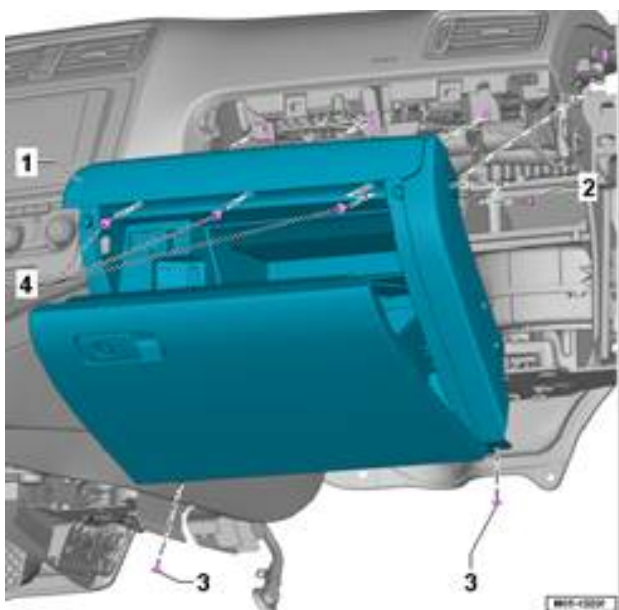

- Disassemble the glove box
- See repair manual/ body/ body interior/ 68 interior equipment/ removal and installation/ storage compartment and covers in Elsa (Figure 8).

Figure 8

Technical Bulletin

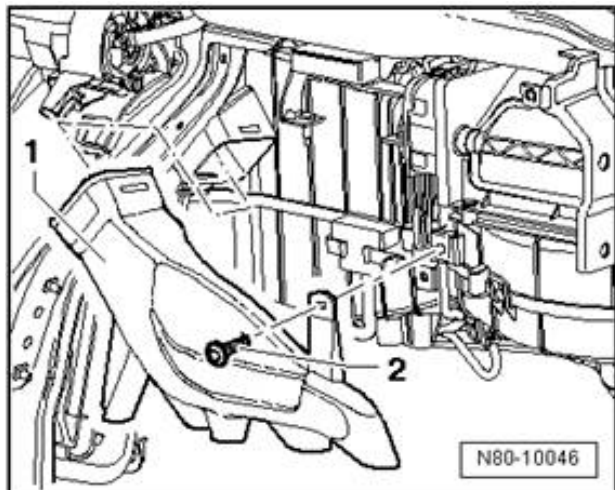

- Remove the right foot duct assembly (Figure 9).

Figure 9



- Insert the right side (black) temperature flap lever (Figure 10).

Figure 10

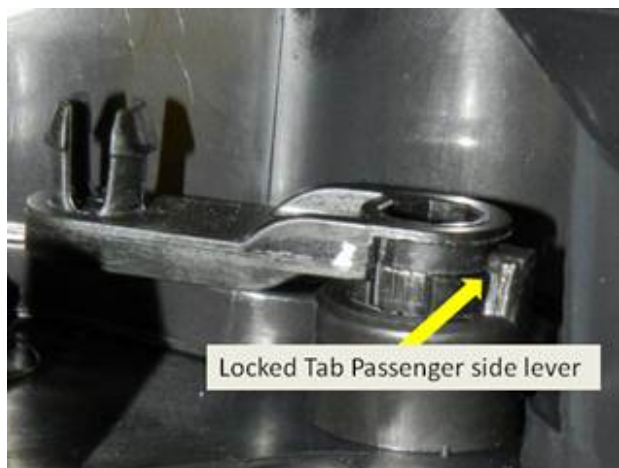

- Make sure the right flap lever is fully inserted behind the lock tab (Figure 11).
- Reassemble the foot vent and glove box assembly.
- Check operation of the temperature controls.

! Note:

The right side temp lever does not have any linkage that needs to be assembled.

Figure 11



Technical Bulletin

Warranty

To determine if this procedure is covered under Warranty, always refer to the Warranty Policies and Procedures Manual ¹⁾					
Model(s)	Year(s)	Eng. Code(s)	Trans. Code(s)	VIN Range From	VIN Range To
Jetta	2013	All	All	All	All
Jetta Hall 84	2014	All	All	AJ_EM350000	AJ_EM426630
Jetta Hall 04	2014	All	All	AJ_EM200001	AJ_EM282126
SAGA Coding					
Claim Type:		Use applicable Claim Type ¹⁾			
Service Number:	Damage Code	HST		Damage Location (Depends on Service No.)	
8515	0010	--		Use applicable when indicated in ElsaPro (L/R)	
Parts Manufacturer		Jetta		3VM ²⁾	
Labor Operation ³⁾ : Remove and Install Glove Compartment			68151900 = 30 TU		
Labor Operation ³⁾ : Modify air distribution unit			85153299 = 10 TU		
Causal Part:			5C0 898 001		
Diagnostic Time ⁴⁾					
GFF Time expenditure	01500000 = 00 TU max.			NO	
Road Test	01210002 = 00 TU 01210004 = 00 TU			NO	
Technical Diagnosis	01320000 = 00 TU max.			NO	
Claim Comment: Input "As per Technical Bulletin 2037255" in comment section of Warranty Claim.					
¹⁾ Vehicle may be outside any Warranty in which case this Technical Bulletin is informational only					
²⁾ Code per warranty vendor code policy.					



Technical Bulletin

³⁾ Labor Time Units (TUs) are subject to change with ELSA updates.

⁴⁾ Documentation required per Warranty Policy Procedures Manual.

Required Parts and Tools

Part Description	Part No:	Quantity
Flap Lever Kit	5C0 898 001	1

No Special Tools required.

Additional Information

All part and service references provided in this Technical Bulletin are subject to change and/or removal. Always check with your Parts Dept. and Repair Manuals for the latest information.