



# Technical Bulletin

---

Model(s)	Year(s)	Eng. Code(s)	Trans. Code(s)	VIN Range From	VIN Range To
Routan	2010	All	6 spd. Automatic (LGG)	All	All

## Condition

**38 15 01** February 3, 2015 **2024846** Supersedes T. B. V381302 dated July 16, 2013 to update part and tool numbers in the required parts and tools section.

### Transfer Gear Bearing Noise

Customers may indicate that they hear a high pitch noise or growl coming from the left side of the vehicle. If the symptom is present, perform the following Repair Procedure.

## Technical Background

Some vehicles may have been built with transmission transfer gear bearings that have an incorrect bearing preload, which can result in transfer gear bearing noise.

## Production Solution

Improved preload specification introduced into production as of July 28<sup>th</sup> 2010.

# Technical Bulletin

## Service

### Procedure

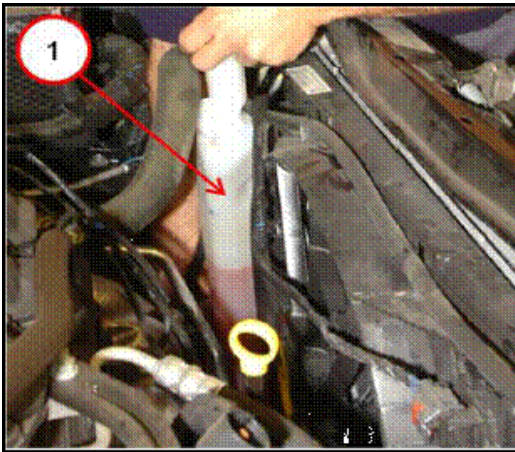

- Open hood
- Disconnect and isolate the negative battery cable.
- Remove the battery.
- Disconnect the radiator overflow hose from the radiator filler neck.
- Remove the engine coolant overflow bottle (1).

The bottle is secured to the radiator support by bayonet style attachments. Remove the coolant recovery container by pulling the coolant bottle upwards off of the radiator fan shroud.

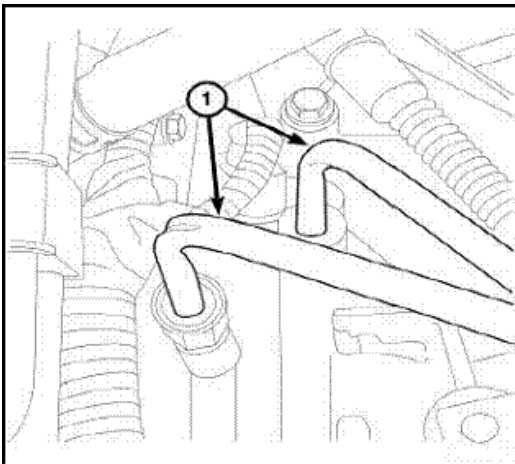

- 3.8L vehicles, remove the exhaust cross over pipe, see repair manual group 26 Exhaust System, Emission Control in ElsaWeb.
- Place a drain pan under the transmission.
- Disconnect the oil cooler lines (1) from transaxle using Trans Cooler Disconnect tool 8875A.
- Allow residual transmission fluid to drain into the drain pan and then move the lines out of the way.

# Technical Bulletin

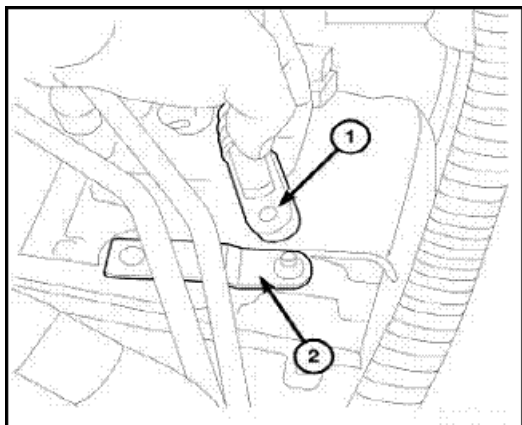

- Remove shift cable (1) from manual valve lever (2).

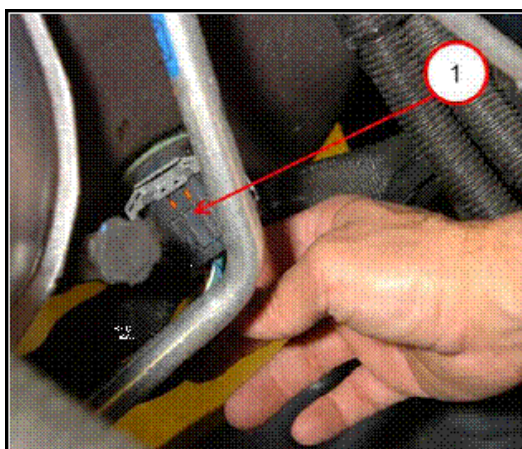

- Remove the solenoid pack connector (1) at the valve body oil pan.

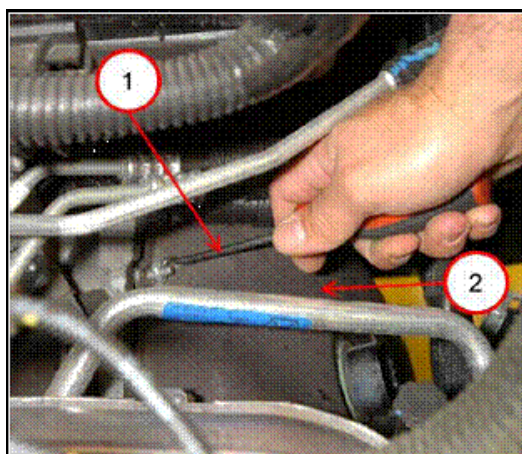

- Remove the engine coolant heater tube hold down clamp bolt located at the left side of the engine.
- Remove the engine coolant heater tube hold down clamp attached at the front of the engine
- Position the engine coolant heater tube out of the way.
- Remove the three valve body oil pan sound deadener retaining clips (1), and remove the sound deadener (2).

# Technical Bulletin

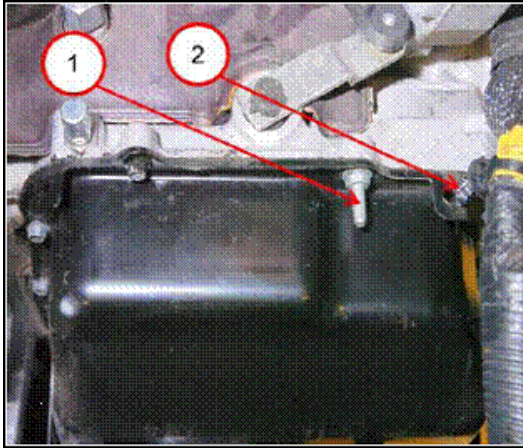

- Take note of each sound deadener stud (1) location (x3) for reference later, and remove each stud.
- Remove the wiring harness retaining clip (2) from the valve body oil pan.
- Remove the top valve body oil pan bolts.

- Raise the vehicle on a hoist.
- If the vehicle is equipped with wheel center caps that cover the wheel nuts, remove the left front wheel's cap with an appropriate removal tool utilizing the notch located between the wheel and outer edge of the cap. Use care not to damage the wheel coating.
- Remove left front wheel.

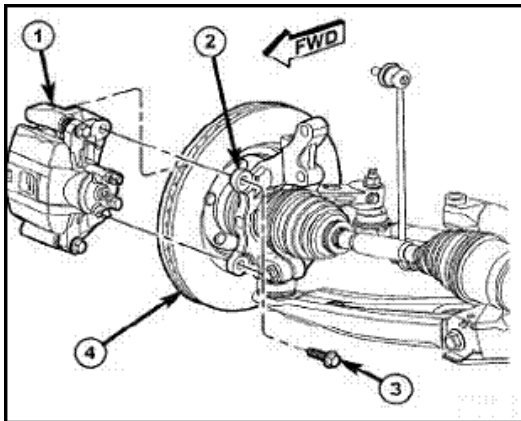

- Remove the two bolts (3) securing disc brake caliper and adapter bracket (1) to the steering knuckle (2).
- Remove brake caliper and bracket (1) from steering knuckle (2) and rotor (4) as a unit, and hang the assembly out of the way. **Use care not to over extend the brake hose.**

# Technical Bulletin

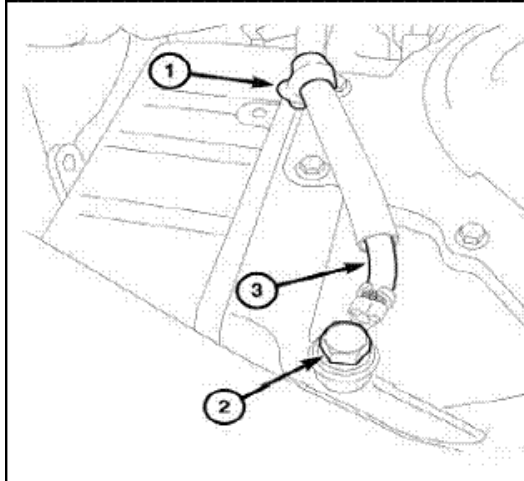

- Rotate steering fully left, and if equipped, remove the bolt (2) at the ground cable.
- If equipped, remove the ground cable clip (1) at the valve body pan and position the cable (3) away from the valve body pan.
- Position a drain pan under the lower oil pan.
- Loosen the lower oil pan bolts and tap the pan at one corner to break it loose allowing the fluid to drain, and then remove the pan.

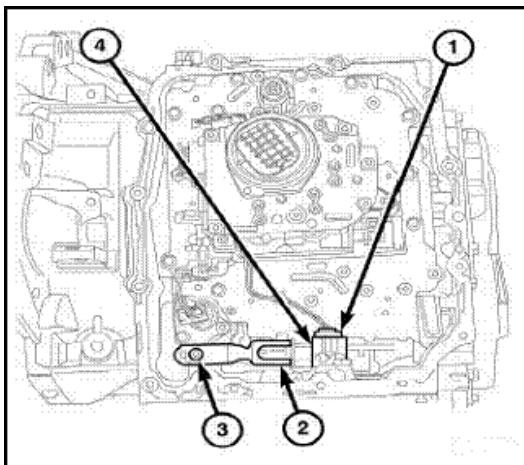

- Remove the nuts at the oil filter and discard filter.
- Remove the lower valve body oil pan bolts.
- Remove the valve body oil pan.
- Remove the electrical connector (1) at the valve body.

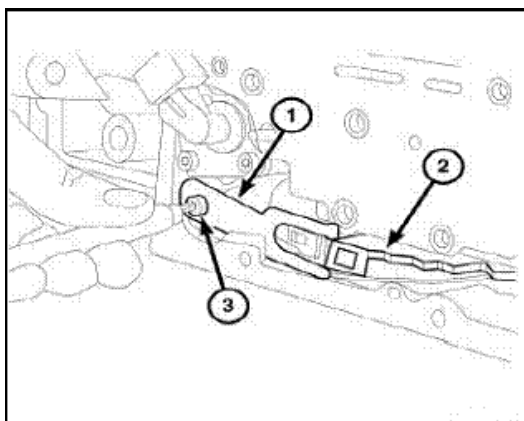

- Remove the screw (3) at the detent arm (1) and remove arm.



# Technical Bulletin

---

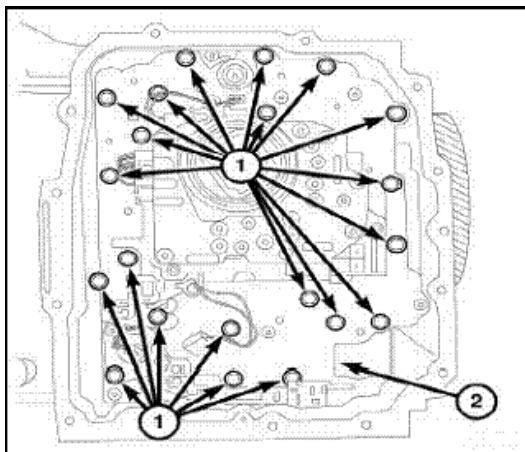

- Remove the 21 valve body to case bolts (1). **One valve body bolt is hidden by the manual valve rooster comb.**

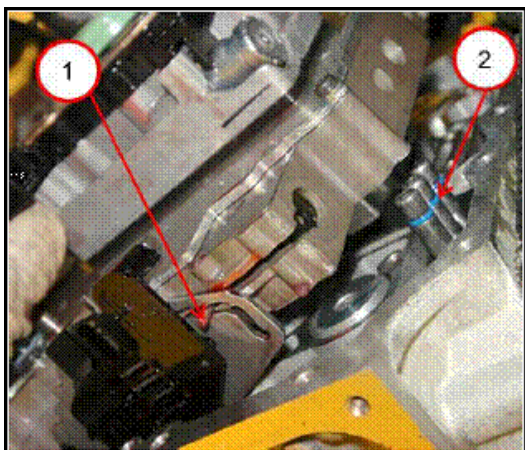

- Pull the valve body away from the underdrive compounder oil transfer tubes (2).

# Technical Bulletin

---

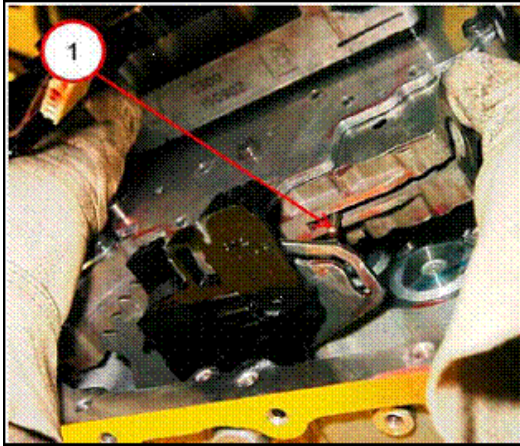

- Lift up on the valve body to clear the manual valve pin (1) past the slot in the rooster comb.

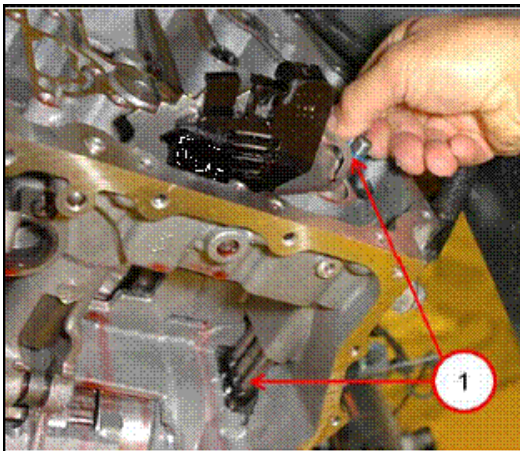

- Separate the underdrive compounder transfer tubes (1) from the underdrive compounder.



- Remove tubes (1).

# Technical Bulletin

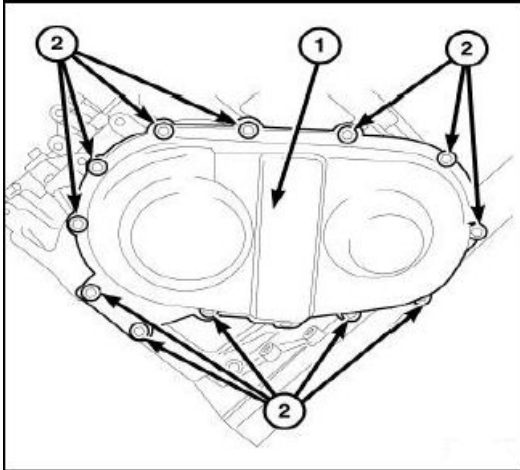

- Remove transfer gear cover-to-case bolts (2) and remove cover (1).

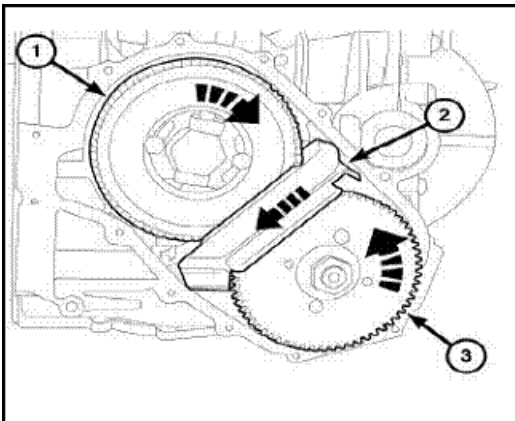

- Remove the oil scavenger (2).

**! Note:**

The scavenger is secured to the transmission case with small tabs. These tabs break easily. Use extreme care when removing the scavenger from the transmission.

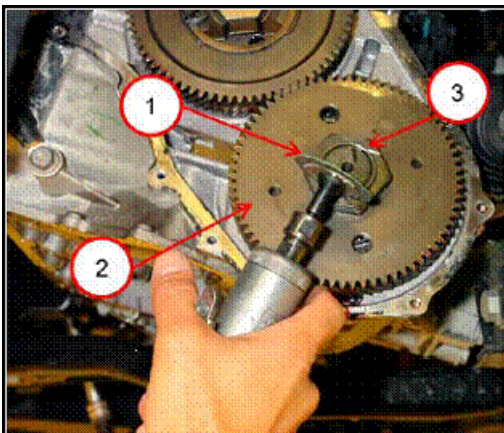

- Grind the staked tabs (3) from the transfer gear (2) (underdrive compounder side). **Take care not to damage the transfer shaft threads.**



# Technical Bulletin

---

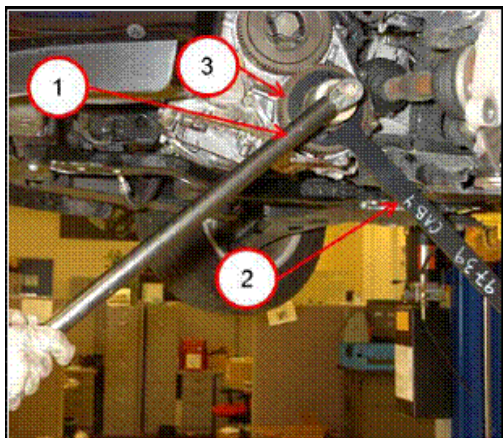

- Install the gear holder (2) P/N 9739 onto the transfer gear (3) (underdrive compounder side) and remove the nut.

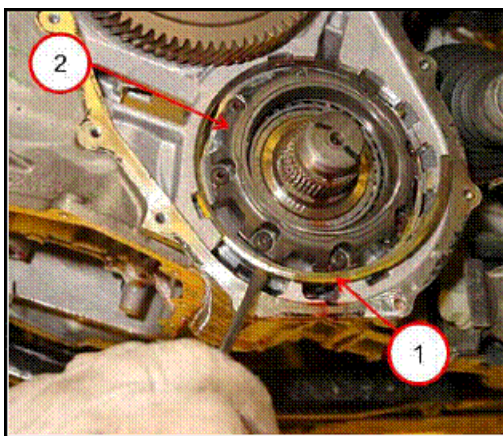

- Remove the snap ring (1) at the underdrive compounder assembly (2).

**! Note:**

The underdrive compounder snap ring is tapered. Note the direction of the snap ring taper before removal so that upon reassembly, it will be installed properly.

# Technical Bulletin

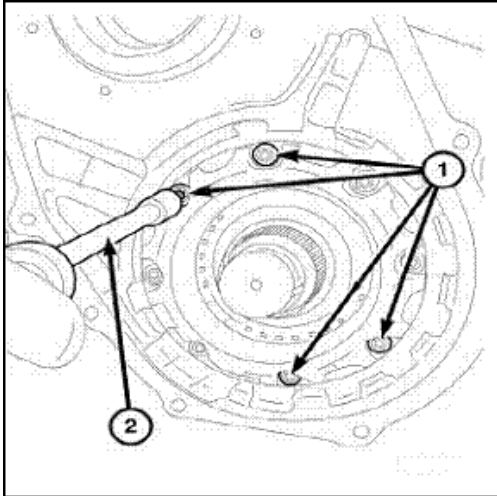

- Using an impact driver (2), loosen all transfer gear bearing retainer screws (1).
- Remove the four screws (1) shown.

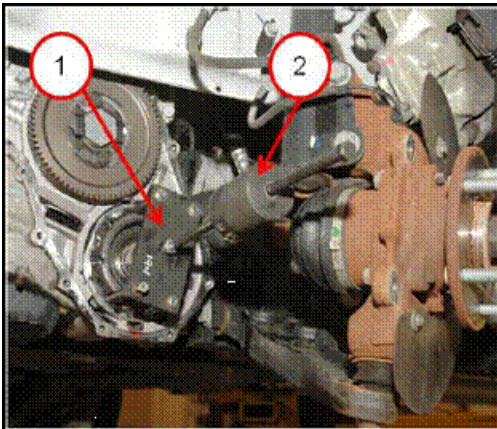

- Install puller adaptor (1) P/N 9908 to the compounder bearing retainer.

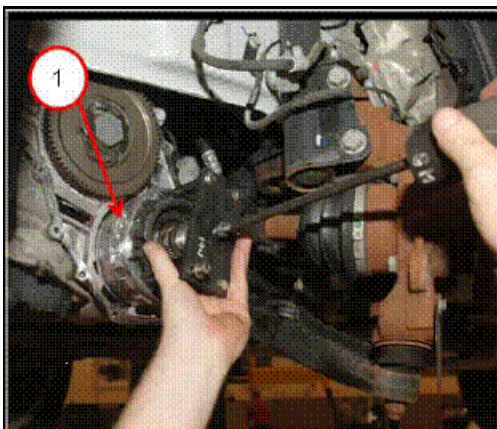

- Install slide hammer P/N C-3752 to puller adaptor P/N 9908 and pull the underdrive compounder assembly (1) from the case.
- Remove the underdrive compounder assembly.

# Technical Bulletin

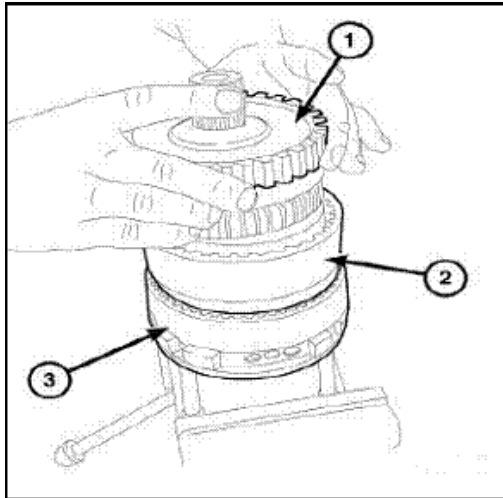

- Remove the slide hammer from the adaptor P/N 9908 and clamp the adaptor into a vise to support the underdrive compounder (3) during the disassembly process.

**! Note:**

The planetary gear set/output hub may still be in the transmission case. If the planetary gear set/output hub is in the transmission, remove it and continue.

- Remove the planetary gear set/output hub (1).

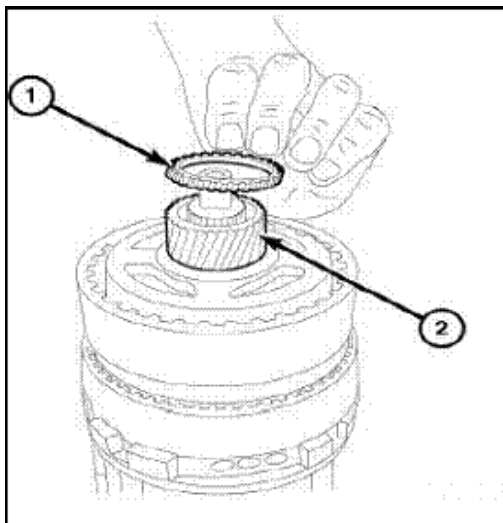

- Remove the helical shim (1).

**! Note:**

If the helical shim is not on the sun gear, it may still be located in the planetary gear set.

It will not be necessary to remove the helical shim from the planetary gear set/output hub.



# Technical Bulletin

---

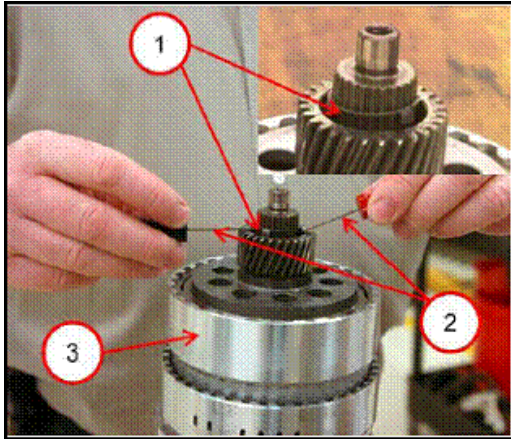

- Using two small picks (2), remove retaining clip (1) from transfer/underdrive shaft. **A new retaining clip will be used during assembly.**
- Remove the sun gear from the shaft.

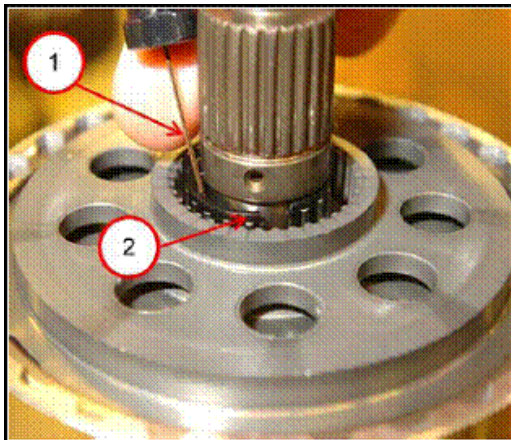

- Remove the split bearing (2) using a small pick.

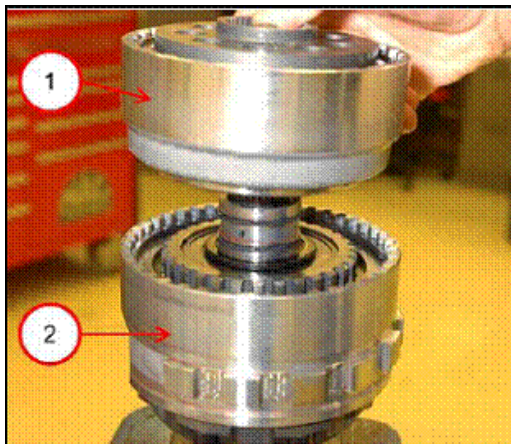

- Remove the underdrive compounder direct clutch (1) from the low clutch (2).



# Technical Bulletin

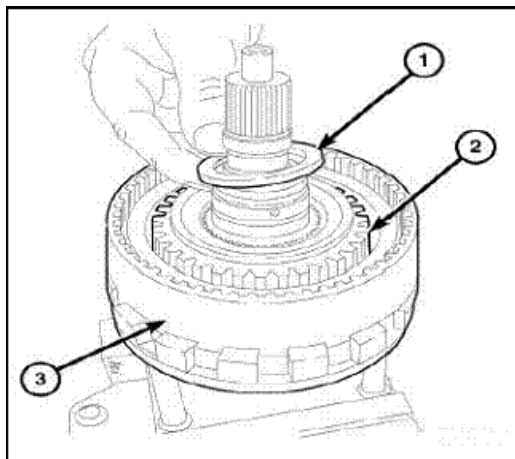

- Remove the thrust bearing (1) from the transfer shaft.

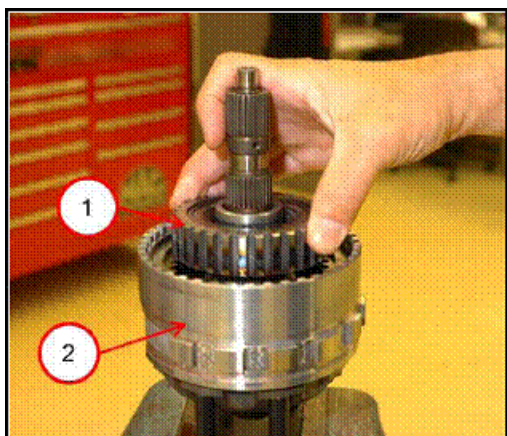

- Remove the overrunning clutch (1) from the low clutch (2).

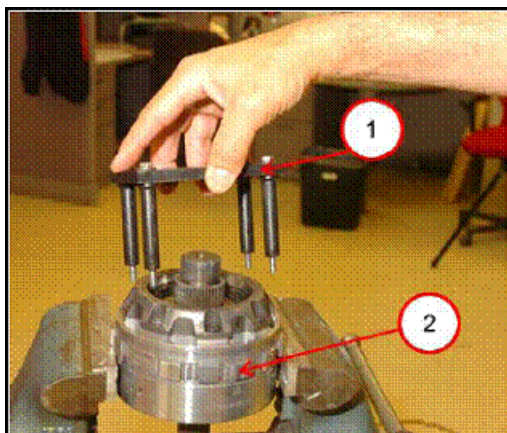

- Carefully clamp the underdrive compounder low clutch (2) into a soft jaw vise.
- ! **Note:**
- Care must be taken not to overtighten the vise as damage to the underdrive compounder low clutch may result.
- Remove puller adapter P/N 9908 (1) from the low clutch.

# Technical Bulletin

---

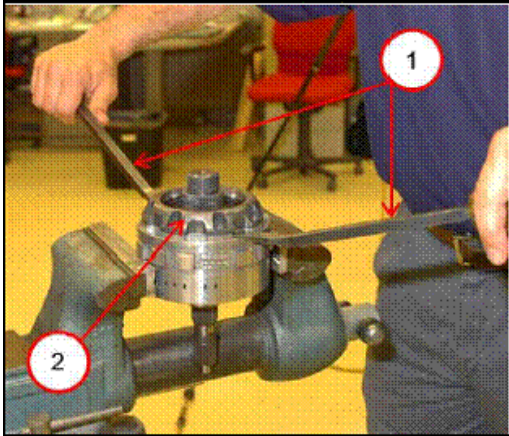

- Remove remaining fasteners securing the transfer shaft bearing retainer and remove the retainer (2).

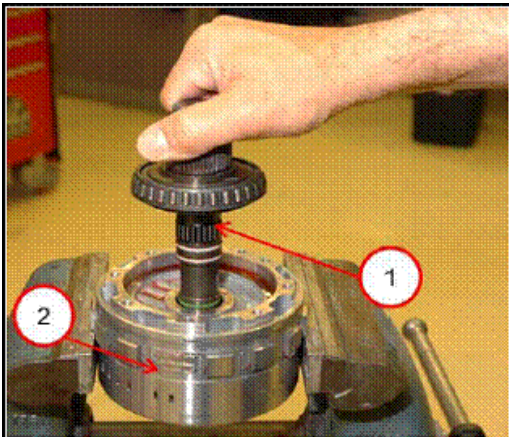

- Remove the transfer shaft (1) from the low clutch (2).

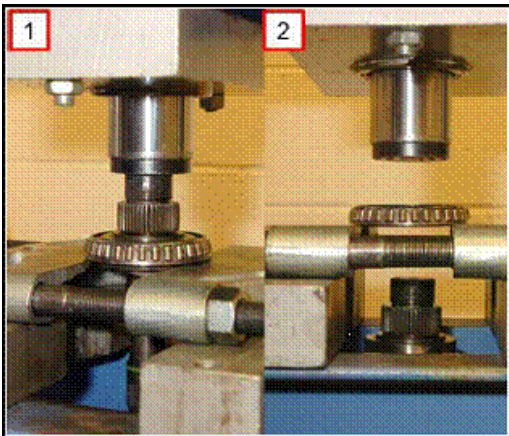

- Using a bearing splitter P/N 1130 (VW Tool 15/3) and a press, remove the transfer shaft bearing.

# Technical Bulletin

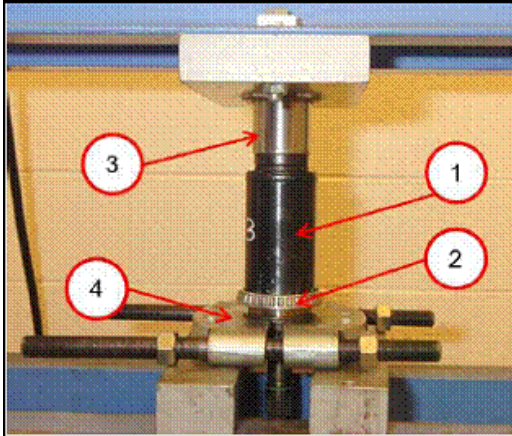

- Using installer P/N 6756 and a press, install the transfer bearing Part. No. **7B0323415A** onto the transfer shaft.

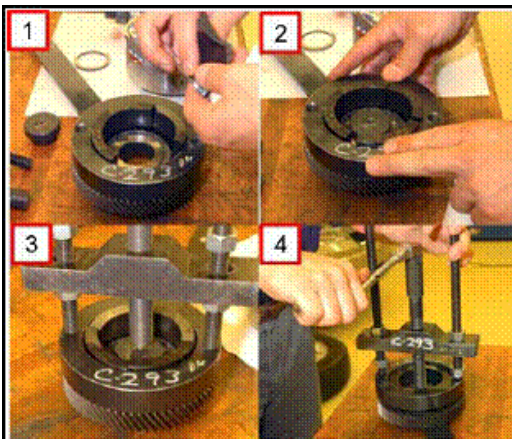

- Using press puller P/N C-293-PA , Adaptors P/N 9738 and a press plug P/N 9678, remove compounder transfer gear bearing cone.



- Install the transfer gear bearing cone Part No. **7B0323415A** using installer Part No. 6756.



# Technical Bulletin

---

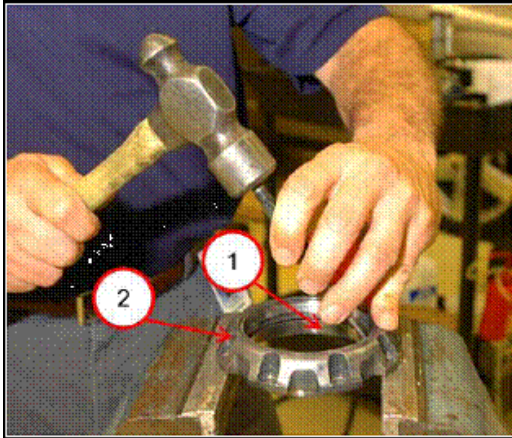

- Using a suitable tool drive the transfer shaft bearing inner race (1) from the transfer shaft bearing retainer (2).

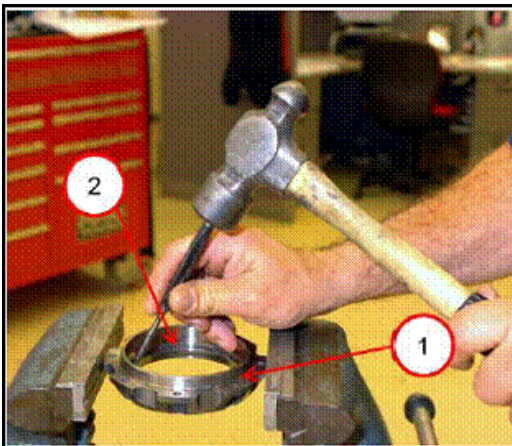

- Using a suitable tool drive the transfer shaft bearing outer race (2) from the transfer shaft bearing retainer (1).

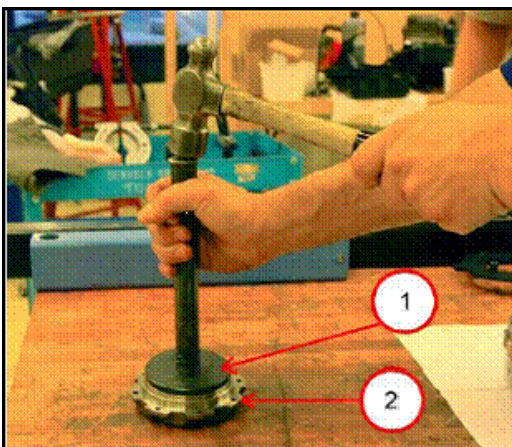

- Install the new bearing inner race into the transfer shaft bearing retainer (2) using Bearing Race Installer 9952 and Handle C4171 (1).



# Technical Bulletin

---

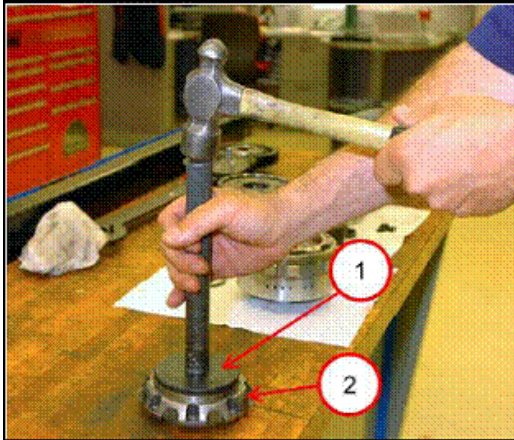

- Install the new bearing outer race into the transfer shaft bearing retainer (2) using Bearing Race Installer 9952 and Handle C4171 (1).

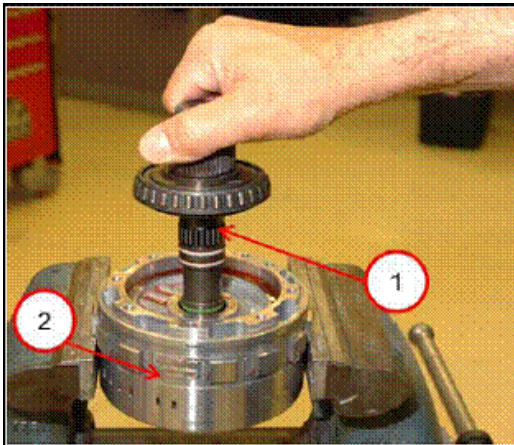

- Install the transfer shaft (1) onto the low clutch (2).
- Lube the transfer shaft and transfer gear bearings with clean ATF Part No. **G 0001621Q** (VW ATF+4).

# Technical Bulletin

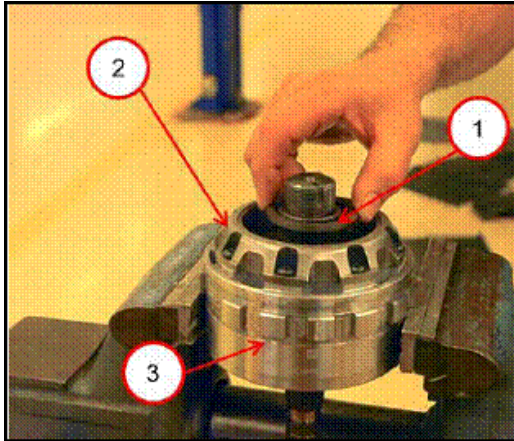

- Install transfer bearing retainer onto the low clutch.
- Install all of the bearing retainer screws and tighten to 12 Nm (105 in. lbs.).
- Install the selectable shim.

**! Note:**

The selectable shim will determine turning torque.

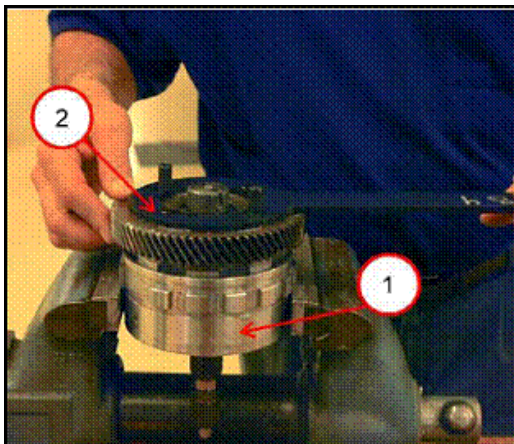

- Install the transfer gear onto the transfer shaft (1) and Holder Part No. 9739 onto the transfer gear (2).

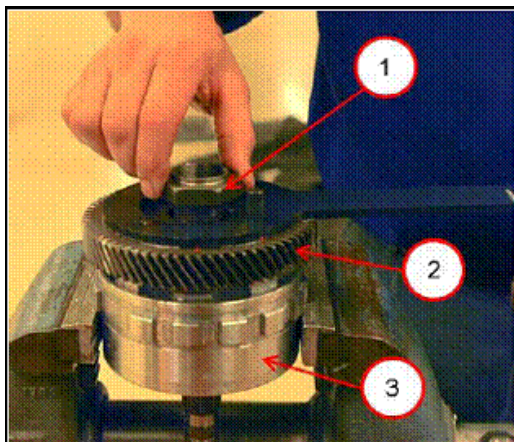

**! Note:**

Care must be taken not to overtighten the vise as damage to the underdrive compounder low clutch may result.

- Install transfer gear nut (1).

# Technical Bulletin

---

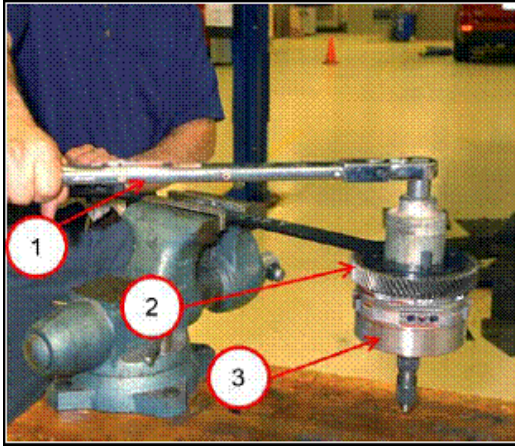

- Clamp Holder 9739 into vise as shown.
- Tighten transfer gear (2) nut to 271 Nm (200 ft. lbs.).
- Remove holder 9739 from transfer gear.
- Carefully clamp the underdrive compounder low clutch into a soft jaw vise.

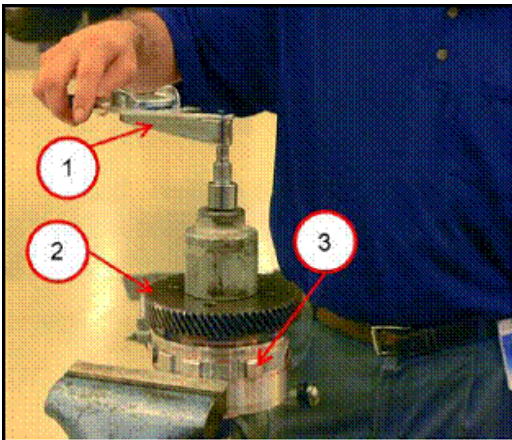

- Rotate the transfer gear (2) four complete revolutions clockwise, and then four complete revolution counter-clockwise to seat the new bearings.
- Check turning torque using an inch pound beam style torque wrench (1). Initial break away torque should be disregarded. Turning torque should be between 4.0 and 12.0 in. lbs. (drag). If more than 12.0 in. lbs. (drag), choose a larger shim and recheck turning torque. If less than 4.0 in. lbs. (drag), choose a smaller shim and recheck turning torque.



# Technical Bulletin

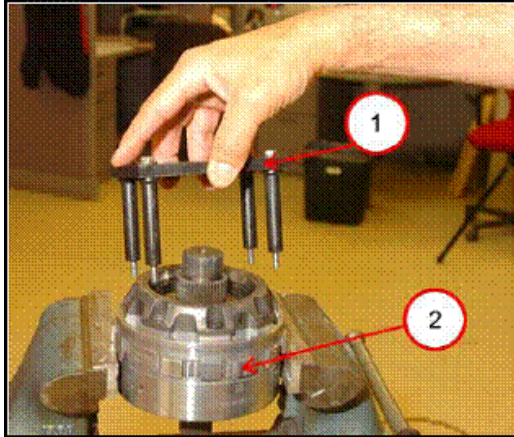

- Install Holder 9739 (1) onto transfer gear and clamp the holder into a vise.
- Remove transfer gear nut and gear.
- Install the Bearing Retainer Assembly Adaptor 9908 onto the low clutch.
- Clamp adapter into a vise to support the underdrive compounder during assembly process.

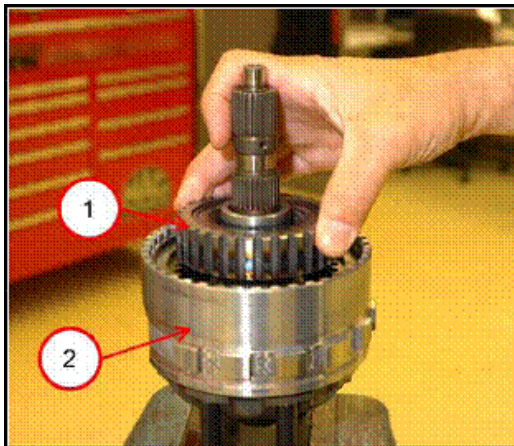

- Install overrunning clutch (1) into low clutch (2).

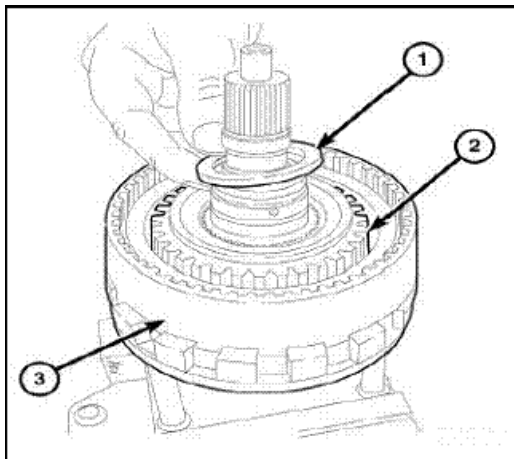

- Install thrust bearing (1) onto transfer shaft.



# Technical Bulletin

---

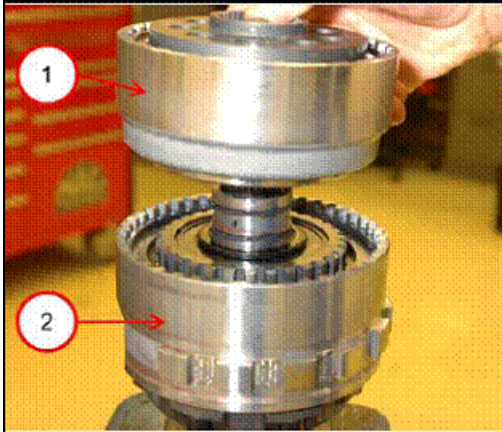

- Install the direct clutch (1) onto the low clutch (2).

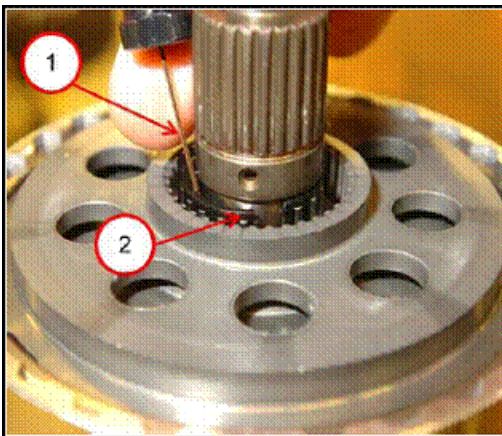

- Install split bearing (2) and lock into place.

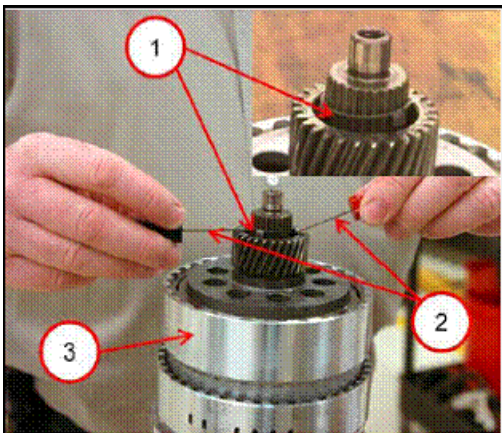

- Install sun gear onto the shaft.
- Install the new sun gear retaining clip (1) Part No. 7BO323433AE onto the transfer/underdrive shaft.

# Technical Bulletin

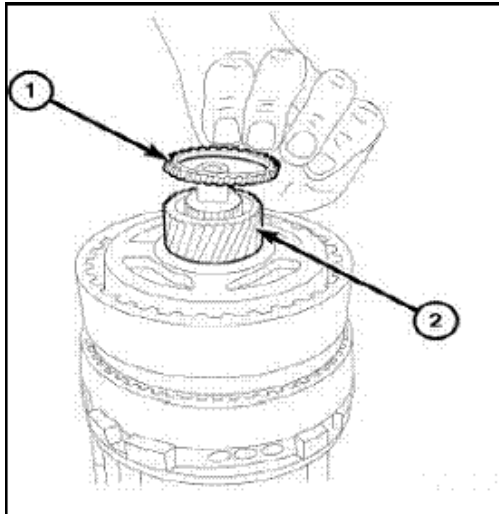

- If necessary, install the helical shim (1).

**! Note:**

- If the helical shim is not on the sun gear, then it still may be located in the planetary gear set. It will not be necessary to remove the helical shim from the planetary gear set/output hub.

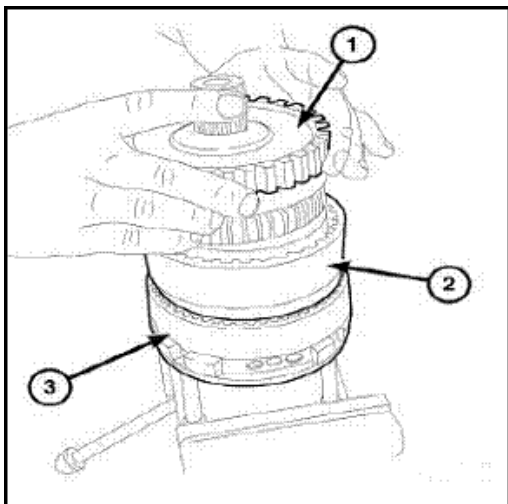

- Install the planetary gear (1) set/output hub onto the direct clutch (2).

# Technical Bulletin

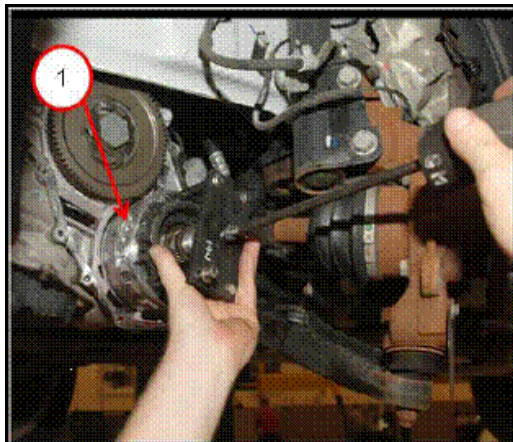

- Install the underdrive compounder (1) assembly into the tranaxle case.
- Remove Adaptor 9908 from compounder bearing retainer.
- Install all the bolts at the compounder bearing retainer and tighten to 12 Nm (105 in. lbs.)

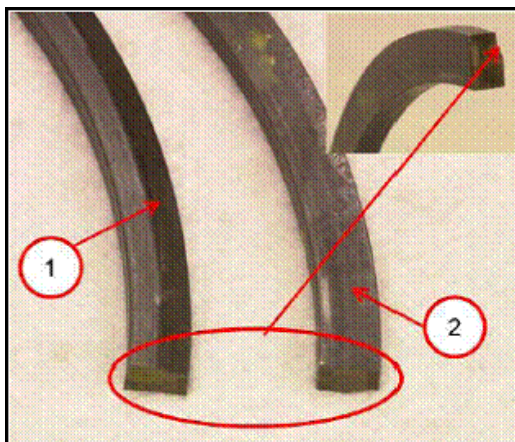

- Install underdrive compounder snap ring at top of the compounder bearing retainer

1= Tapered side

2=Flat side

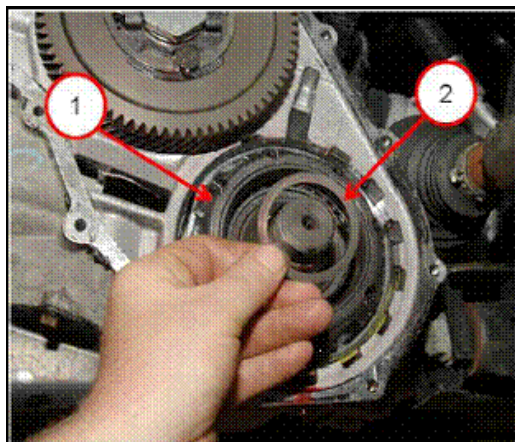

- Make sure select fit shim (2) is located on the transfer shaft (1) prior to installing the transfer gear.



# Technical Bulletin

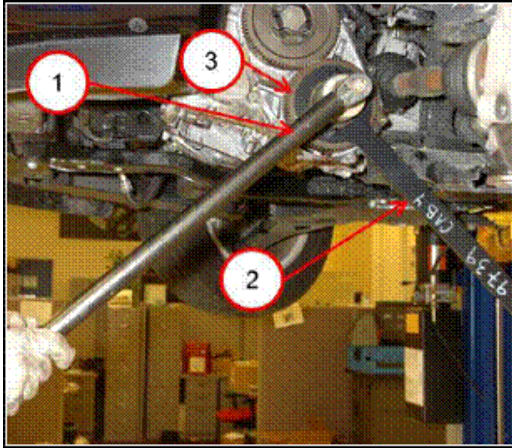

- Install transfer gear (3) onto transfer shaft.
- Install Holder (2) 9739 onto the transfer gear (underdriver compounder side).
- Install new transfer gear (underdrive compounder side) nut Part No. WHT004510 and tighten to 271 Nm (200 ft. lbs.).
- Use stake tool 9721 and stake new nut.

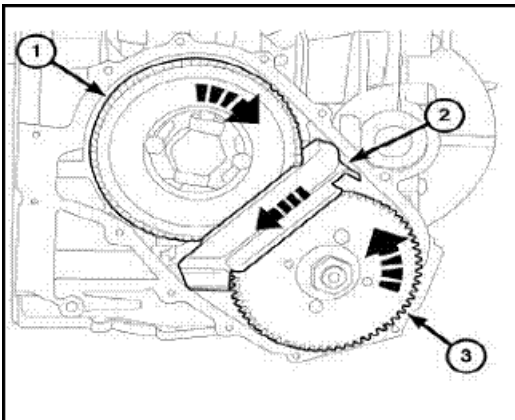

- Clean the transfer gear cover sealing surface and mating surface.
- Install the oil scavenger (2).

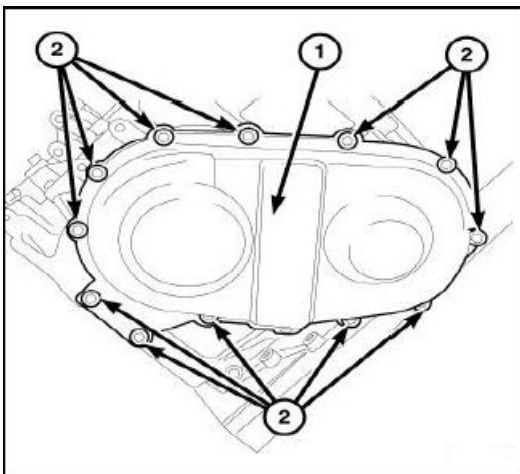

- Spread a bead of sealant Part No. D 1763212O onto the transfer gear cover sealing surface.
- Install transfer gear cover (1) to case bolts (2) and tighten to 12 Nm (105 in. lbs.).



# Technical Bulletin

---

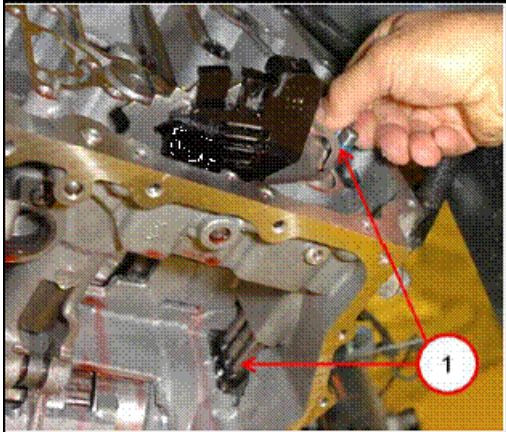

- Install the underdrive compounder oil transfer tubes (1) into the underdrive compounder.

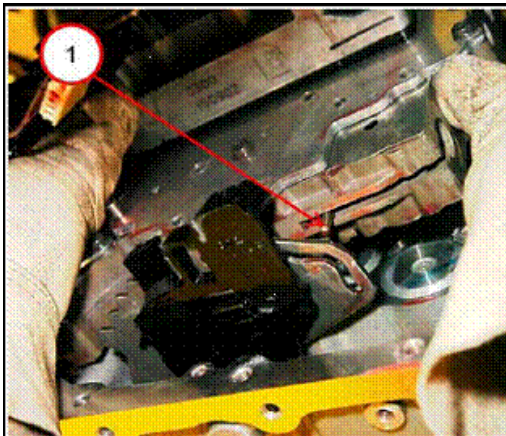

- Position the valve body near the underdrive compounder oil transfer tubes and slide the valve body manual valve pin (1) into the slot in the rooster comb.

# Technical Bulletin

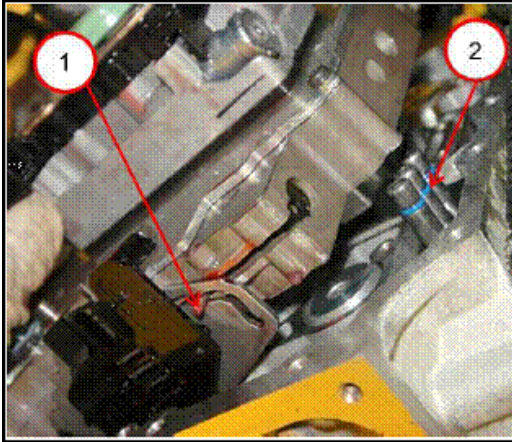

- Slide the valve body onto the underdrive compounder transfer tubes (2).

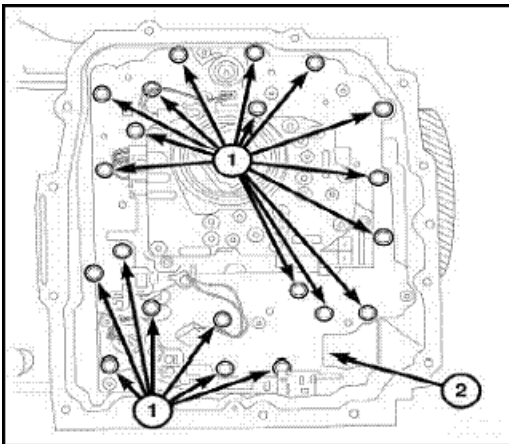

- Install the twenty one valve body to case bolts and tighten to 6 Nm (50 in. lbs.).

**! Note:**

Valve body to case bolt torque is critical during valve body installation. Failure to torque bolts could result in improper operation.

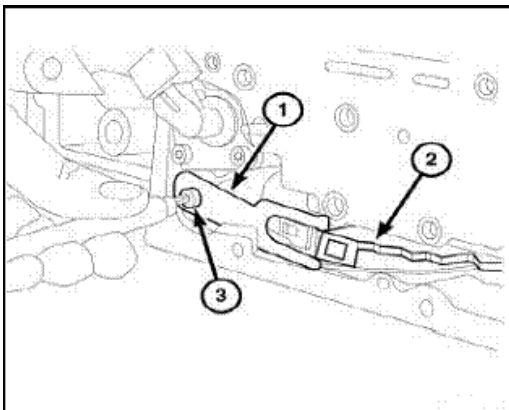

- Install the detent arm (1) onto the pin at the valve body.
- Install the screw (3) at the detent arm and tighten to 6 Nm (50 in. lbs.).

# Technical Bulletin

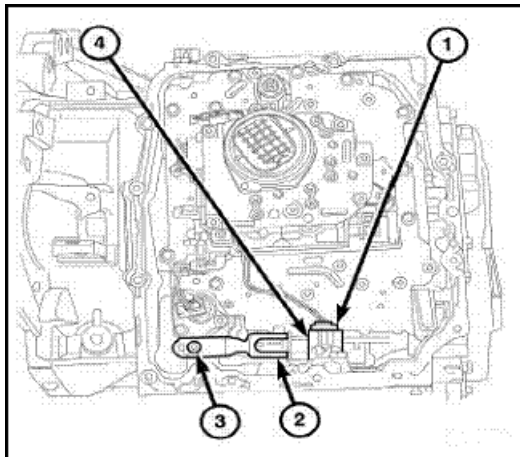

- Install the electrical connector at the valve body.
- Install new transmission filter and nuts, tighten to 5 Nm (40 in. lbs.).
- Clean the oil pan and magnet.
- Spread a bead of Sealant Part No. **D 1763212O** onto the oil pan sealing surface.
- Install oil pan and tighten oil pan bolts to 6 Nm (50 in. lbs.).

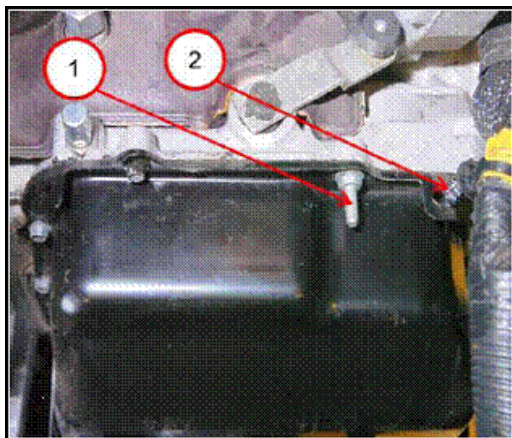

- Spread a bead of Sealant Part No. **D 1763212O** onto the valve body oil pan sealing surface.
- Install the valve body oil pan and tighten bolts to 12 Nm (105 in. lbs.).

**! Note:**

Install the three oil pan studs in the locations recorded in removal procedure.

- If equipped, install the ground cable and tighten bolt.
- If equipped, install the ground cable clip at the valve body pan.
- Install the disc brake caliper and adaptor bracket assemble over the rotor and knuckle.
- Install the mounting bolts securing the caliper adapter bracket to the knuckle and tighten bolts to 169 Nm (125 ft. lbs.).
- Place wheel and tire into position on hub and lightly snug all five wheel mounting nuts. **DO NOT** tighten wheel at this time.
- Lower vehicle.
- Progressively tighten all wheel mounting nuts in the proper sequence. Tighten nuts to a final torque of 135 Nm (100 ft. lbs.).
- If applicable, install wheel center cap.



# Technical Bulletin

---

- Install the wire harness retaining clip onto the valve body oil pan.
- Install the three valve body sound deadener retaining clips Part No. WHT004266.
- Reposition the engine coolant heater tube and secure the tube with the hold down bolt located on the left side of the engine, and the hold down clamp bolt attached to the front of the engine.
- Attach the solenoid pack connector at the valve body oil pan and secure it with the connector lock.
- Install the shift cable onto the manual lever.
- Reconnect the oil cooler lines onto the transaxle.
- 3.8L vehicles, install the exhaust crossover pipe.
- Reconnect radiator over flow hose onto the radiator fill neck and install the recovery bottle.
- Install Battery.
- Top off transmission fluid with Part No. ATF Part No. **G 0001621Q** (VW ATF+4).





# Technical Bulletin

## Warranty

All Routan pre and post road test, StarMOBILE and wiTECH time units are included in the labor operation. Therefore, no road test time units will appear in the designated area within the warranty table.

<b>To determine if this procedure is covered under Warranty, always refer to the Warranty Policies and Procedures Manual <sup>1)</sup></b>					
Model(s)	Year(s)	Eng. Code(s)	Trans. Code(s)	VIN Range From	VIN Range To
Routan	2010	All	6 spd. Automatic (LGG)	All	All
Claim Type:	Use applicable Claim Type <sup>1)</sup>				
<b>SAGA Coding</b>					
Service Number:	Damage Code	HST	Damage Location (Depends on Service No.)	Parts Manufacturer (removed part)	
3911	0020	CWM 2024846	Use applicable when indicated in ElsaWeb (L/R)	U S M <sup>2)</sup>	
Labor Operation <sup>3)</sup> : 4.0L Only			39112099 = 470 TU (includes pre and post repair road test)		
Labor Operation <sup>3)</sup> : 3.8L Only			39116099 = 520 TU (includes pre and post repair road test)		
Causal: 4.0L select labor operation			39112099		
Causal: 3.8L select labor operation			39116099		
<b>Diagnostic Time <sup>4)</sup></b>					
GFF Time expenditure	01500000 = XX TU max.		NO		
Road Test	01210002 = 10 TU 01210004 = 10 TU		Included in Labor time		



# Technical Bulletin

Technical Diagnosis	01320000 = XX TU max.	NO
Claim Comment: Input "As per Technical Bulletin 2024846" in comment section of Warranty Claim.		
<sup>1)</sup> Vehicle may be outside any Warranty in which case this Technical Bulletin is informational only <sup>2)</sup> Code per warranty vendor code policy. <sup>3)</sup> Labor Time Units (TUs) are subject to change with Elsa updates. <sup>4)</sup> Documentation required per Warranty Policy Procedures Manual.		

## Required Parts and Tools

Legend: AR = as required

Part Description	Part No:	Quantity
Nut, Transfer Gear Retaining	WHT004510	1
ATF-RTV	<b>D 1763212O</b>	1 (AR)
ATF+4	<b>G 0001621Q</b>	8
Spacer, Transfer Shaft Bearing 4.13-4.15 mm (0.1626-0.1634 in.) (expected minimal usage)	7B0323345BD	1 (AR)
Spacer, Transfer Shaft Bearing 4.16-4.18 mm (0.1638-0.1646 in.) (expected minimal usage)	7B0323345BE	1 (AR)
Spacer, Transfer Shaft Bearing 4.19-4.21 mm (0.1649-0.1657 in.) (expected minimal usage)	7B0323345BF	1 (AR)
Spacer, Transfer Shaft Bearing 4.22-4.24 mm (0.1661-0.1669 in.) (expected minimal usage)	7B0323345CA	1 (AR)

# Technical Bulletin

Spacer, Transfer Shaft Bearing 4.25-4.27 mm (0.1673-0.1681 in.) (expected minimal usage)	7B0323345CB	1 (AR)
Spacer, Transfer Shaft Bearing 4.28-4.30 mm (0.1685-0.1693 in.) (expected minimal usage)	7B0323345CC	1 (AR)
Spacer, Transfer Shaft Bearing 4.31-4.33 mm (0.1697-0.1705 in.) (expected minimal usage)	7B0323345CD	1 (AR)
Spacer, Transfer Shaft Bearing 4.34-4.36 mm (0.1709-0.1717 in.) (expected minimal usage)	7B0323345CE	1 (AR)
Spacer, Transfer Shaft Bearing 4.37-4.39 mm (0.1720-0.1728 in.) (expected minimal usage)	7B0323345CF	1 (AR)
Spacer, Transfer Shaft Bearing 4.40-4.42 mm (0.1732-0.1740 in.) (expected minimal usage)	7B0323345DA	1 (AR)
Spacer, Transfer Shaft Bearing 4.43-4.45 mm (0.1744-0.1752 in.) (expected minimal usage)	7B0323345DB	1 (AR)
Spacer, Transfer Shaft Bearing 4.46-4.48 mm (0.1756-0.1764 in.) (expected minimal usage)	7B0323345DC	1 (AR)
Spacer, Transfer Shaft Bearing 4.49-4.51 mm (0.1768-0.1776 in.) (expected minimal usage)	7B0323345DD	1 (AR)
Spacer, Transfer Shaft Bearing	7B0323345DE	1 (AR)



# Technical Bulletin

4.52-4.54 mm (0.1780-0.1787 in.) (expected minimal usage)		
Spacer, Transfer Shaft Bearing 4.55-4.57 mm (0.1791-0.1799 in.) (expected minimal usage)	7B0323345DF	1 (AR)
Snap ring	7B0323433AE	1
Bearing and Cup	7B0323415A	2
Filter kit	7B0325433	1
Gasket	7B0253315	2 (3.8L engine only)
Nut	WHT004266	3

Tool Description	Tool No:
Tube quick connect removal tool	8875A
Gear Holder	9739
Nut staking tool	9721
Impact driver	-
Underdrive compounder puller adapter	9908
Slide hammer	C-3752
Bearing splitter	1130 (VW tool #15/3)
Installer	6756
Press puller	C-293-PA
Adapters	9738
Press plug	9678
Installer	9952





# Technical Bulletin

---

Drive handle	C4171
Wiring terminal removal tool	6682-2 (component of Electrical Terminal Tool Kit 8197A)
Wiring terminal removal tool	6682-3 (component of Electrical Terminal Tool Kit 8197A)

## Additional Information

All part and service references provided in this Technical Bulletin are subject to change and/or removal. Always check with your Parts Dept. and Repair Manuals for the latest information.