



Countries: AUSTRALIA, CANADA, UNITED STATES, MEXICO, NEW ZEALAND
Availability: ISIS
Major System: ACCESSORIES
Current Language: English
Other Languages: NONE
Viewed: 1197

Document ID: IK1900237
Revision: 5
Created: 10/24/2014
Last Modified: 7/2/2015
Author: Kevin Kochanek

[Less Info](#)

Hide Details

Coding Information

Copy Link 	Copy Relative Link 	Bookmark View My Bookmarks	Add to Favorites 	Print 	Provide Feedback 	Helpful 1	Not Helpful 1
----------------------	-------------------------------	--	-----------------------------	------------------	-----------------------------	-------------------------	-----------------------------

Title: Symptom 3: No-Idle HVAC Inoperative

Applies To: ProStar® and LoneStar®

CHANGE LOG

Please refer to the change log text box below for recent changes to this article:

<ul style="list-style-type: none"> 11/21/2014 - Initial Article Release 02/23/2015 - Revision 1 03/06/2015 - Added Warranty and SRT Information 07/1/2015 - Added link to IK1900238 in Step 7

DESCRIPTION

This document will guide the user through the steps necessary to diagnose No-Idle Inoperative.

SYMPTOM(s)

Diagnostic Trouble Code(s) & Dashboard Indicator Light(s):

Not Applicable

DTC/Light	Description
Not Applicable	

Customer Observations or Concerns:

- Discharged batteries
- Loose connections
- Blown fuse
- Fault code
- Broken wire or defective harness
- Park brake switch defective or wrong logic
- Blend door to housing obstruction
- Defective control panel switch
- Failed system controller
- Failed Linear Power Module (LPM)
- Failed evaporator blower motor
- Failed blend door actuator
- Failed condenser fan
- Failed compressor controller
- Failed compressor
- Refrigerant leak

SPECIAL TOOL(s) / SOFTWARE

Tool Description	Tool Number	Comments	Instructions

Relay Breakout Harness (or Navistar Test Lead Kit)	ZTSE4674 (or NAV-77066)		
--	-------------------------	--	--

[Tools Resource Center](#)

SERVICE PARTS INFORMATION

Not Applicable

Kit Description	Part Number	Quantity Required	Notes
Not Applicable			

DIAGNOSTIC STEP(s)

WARNING:

To prevent property damage, personal injury, and / or death, park vehicle on a hard, flat surface, turn engine off, set parking brake, and install wheel chocks to prevent vehicle from moving in either direction.

WARNING:

To prevent personal injury and / or death, always wear safe eye protection when performing vehicle maintenance.

CAUTION:

To prevent damage to components, do not attempt to connect battery voltage to evaporator blower motor, condenser fan motor, or A/C compressor. Electronic components within the motors are sensitive to arcing and reverse polarity.

NOTE:

Perform all of the following steps Key-OFF and Park Brake set unless otherwise directed.

NOTE:

When disconnecting harness connectors, check for pushed-back and damaged terminals.

NOTE:

After any step where a problem is detected, repair as needed and retest for original concern.

NOTE:

If operator uses No-Idle A/C with ignition switch in ACCESSORY position, verify park brake input logic to system controller is correct.

NOTE:

Vehicles built with or updated to 150A compressor relays do not use fuse (F2); Circuit protection is provided by cube fuse located in battery box.

NOTE:

When 12V No-Idle system controller senses battery voltage drop below 11.8V for 10 seconds, system will shut down.

NOTE:

No-Idle A/C faults are transferred to Body Controller (BC) at Key-ON handshake between BC and No-Idle system controller. Inactive faults are not stored in the system controller. Only those faults that are active at handshake are transferred.

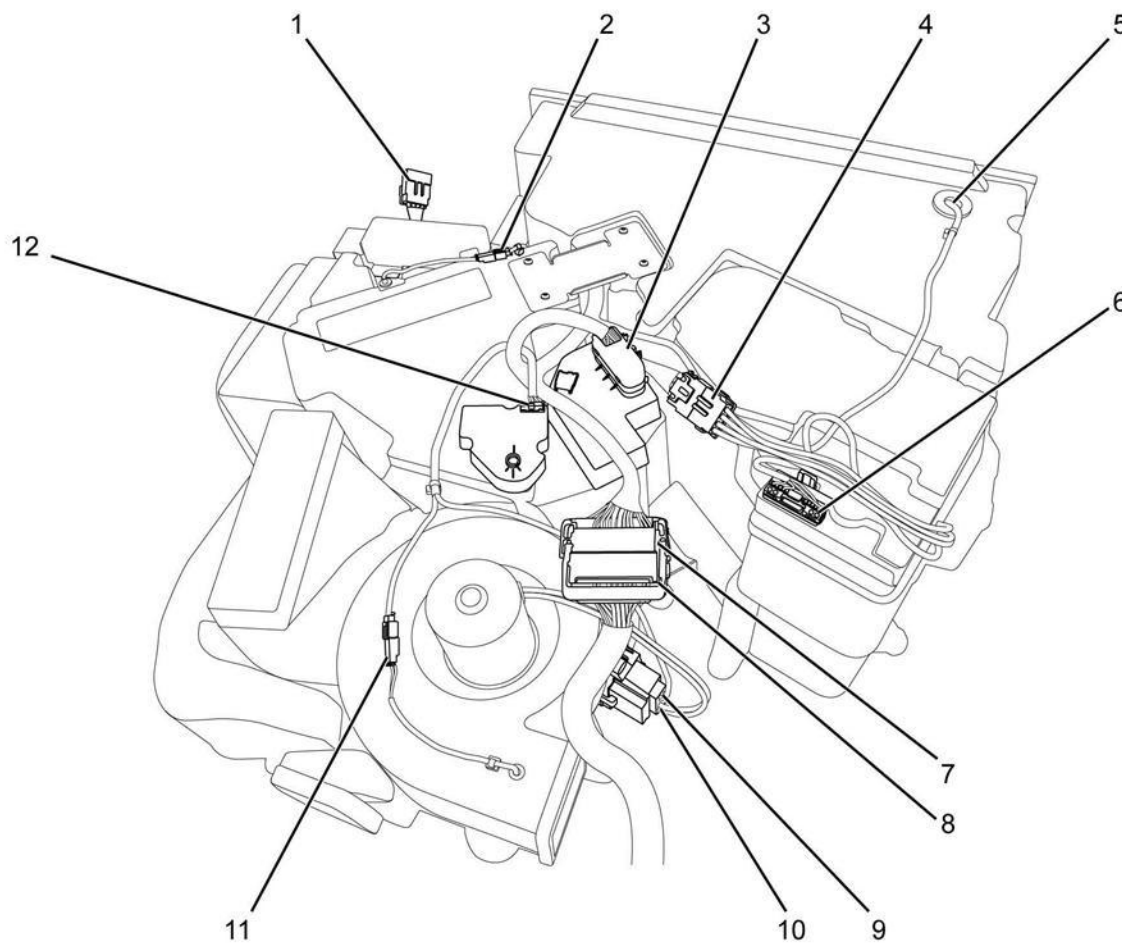

0000340001

Figure 1. 60A Relay Connector Locations.

- Item 1: No-Idle harness power / ground 4-way connector
- Item 2: Inlet temperature sensor 2-way connector
- Item 3: System controller 32-way connector
- Item 4: Compressor power / ground 4-way connector
- Item 5: No-Idle harness to condenser fan 3-way connector
- Item 6: Compressor controller 32-way connector
- Item 7: No-Idle 30-way connector (5205)
- Item 8: Chassis 30-way connector
- Item 9: Linear Power Module (LPM) 6-way connector
- Item 10: LMP 2-way connector
- Item 11: Discharge temperature sensor 2-way connector
- Item 12: Blend door actuator 6-way connector

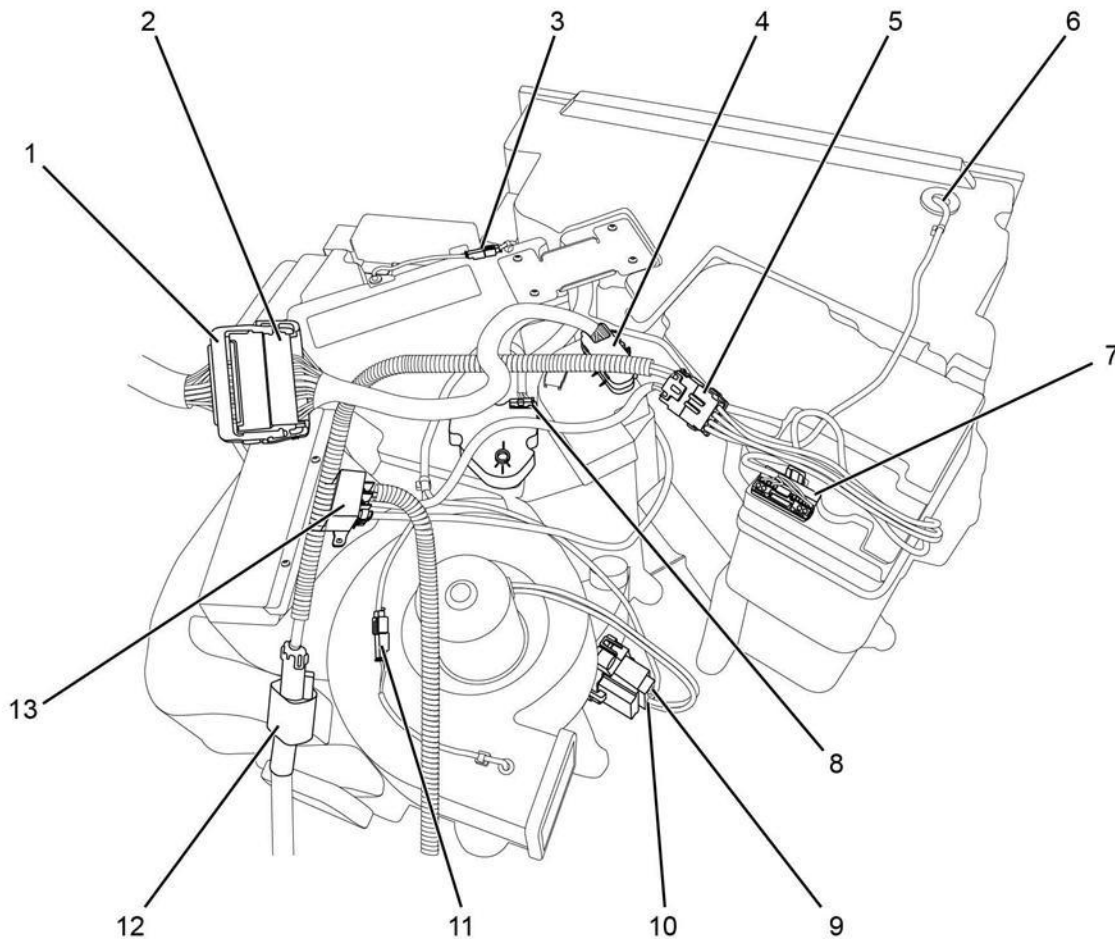

0000340021

Figure 2. 150A Relay Connector Locations.

- Item 1: Chassis 30-way connector
- Item 2: No-Idle 30-way connector
- Item 3: Inlet temperature sensor 2-way connector
- Item 4: System controller 32-way connector
- Item 5: Compressor power / ground 4-way connector
- Item 6: No-Idle harness to condenser fan 3-way connector
- Item 7: Compressor controller 32-way connector
- Item 8: Blend door actuator 6-way connector
- Item 9: LPM 6-way connector
- Item 10: LPM 2-way connector
- Item 11: Discharge temperature sensor 2-way connector
- Item 12: Compressor controller 1-way ground connector
- Item 13: 150A relay

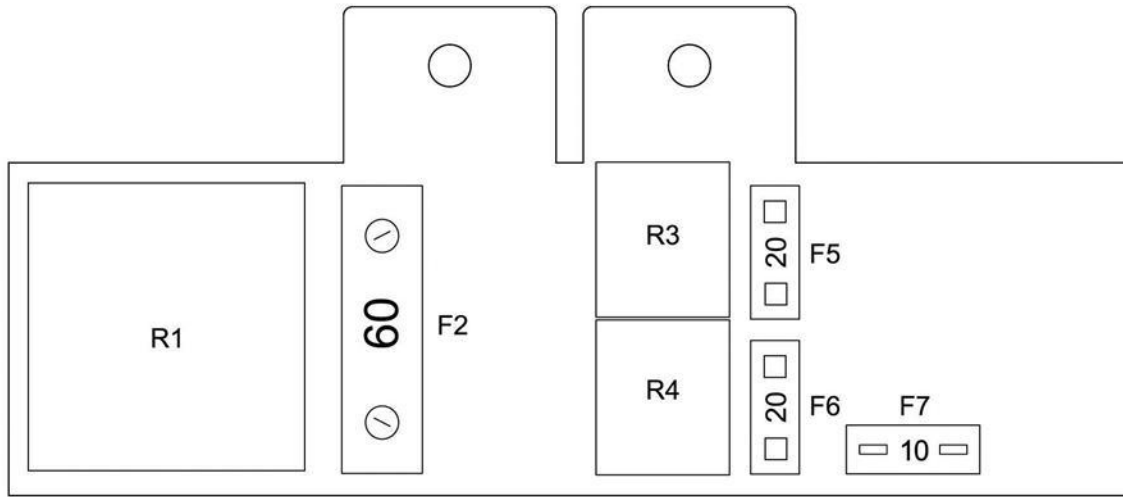

0000331281

Figure 3. Fuse / Relay Locations.

Step	Action	Decision
1	OPERATIONAL CHECK: a. Verify all operational checks have been performed.	Yes. Go to Step 2.
	Have all operational checks been performed?	No. Go to Operational Checks in IK1900235 .

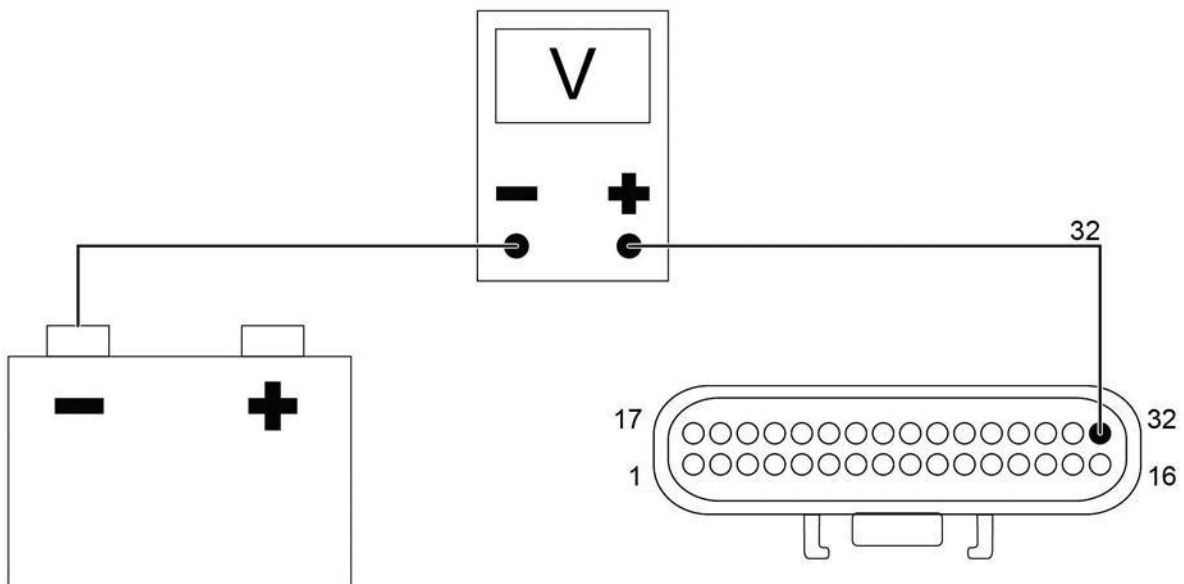

0000320781

Figure 4. 32-Way System Controller Connector Face View.

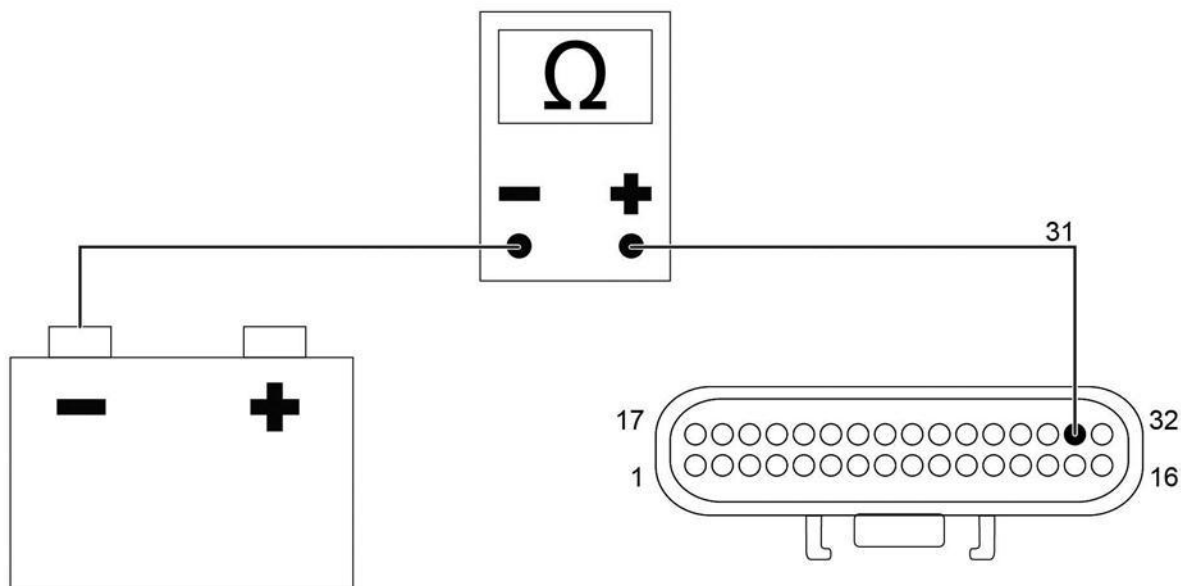

0000320801

Figure 5. 32-Way System Controller Connector Face View.

Step	Action	Decision
2	SYSTEM CONTROLLER PWR / GND CHECK: a. Disconnect 32-way system controller connector.	Yes. Go to Step 3.
	NOTE: Measurement in Step 2.b should be B+.	No. Step 2.b has low or 0.0V: Go to Step 19.
	b. Use a DMM to measure voltage between 32-way system controller connector pin-32 and a known good ground (Figure 4). NOTE: Measurement in Step 2.c should have continuity to ground.	No. Step 2.c has high resistance to ground: Go to Step 18.
	C. Measure Continuity between system controller Pin-31 and a known good ground. Pin-31 should have continuity to battery ground. D. Leave system controller connector unplugged. Do step-B and step-C meet expected readings?	

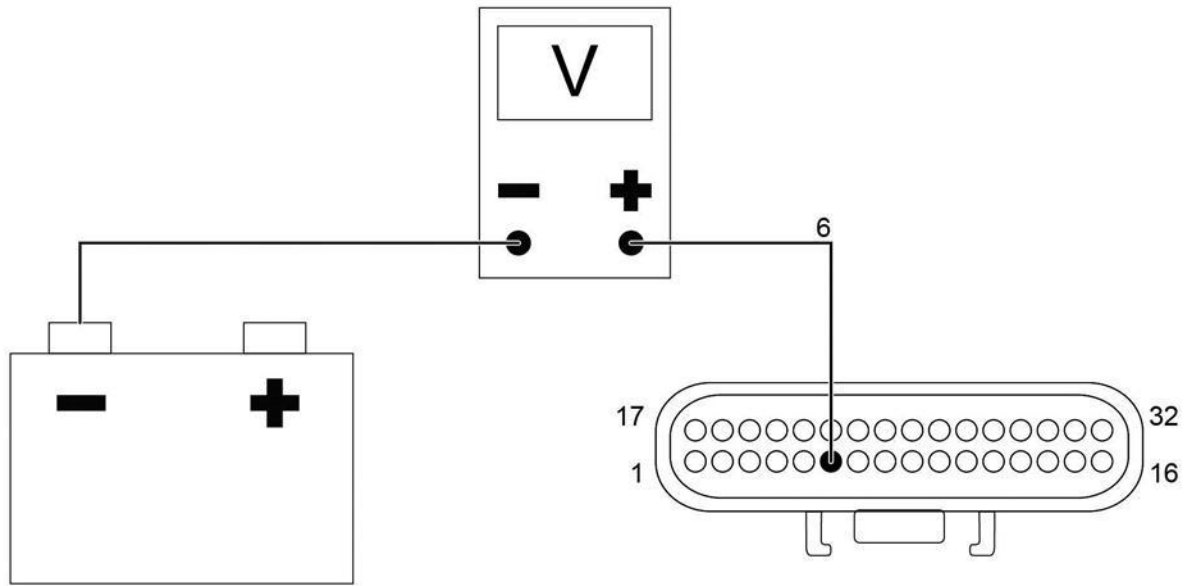

0000320826

Figure 6. 32-Way System Controller Connector Face View.

Step	Action	Decision
	COOL MEMORY SWITCH CHECK:	
	A. Use a DMM to measure voltage at system controller harness connector Pin-6 while holding the COOL switch depressed.	Yes. Leave 32-way system controller connector disconnected and go to Step 4.
3	Does Pin-6 have B+ with switch depressed?	No. Connect 32-way system controller connector and go to Step 20.

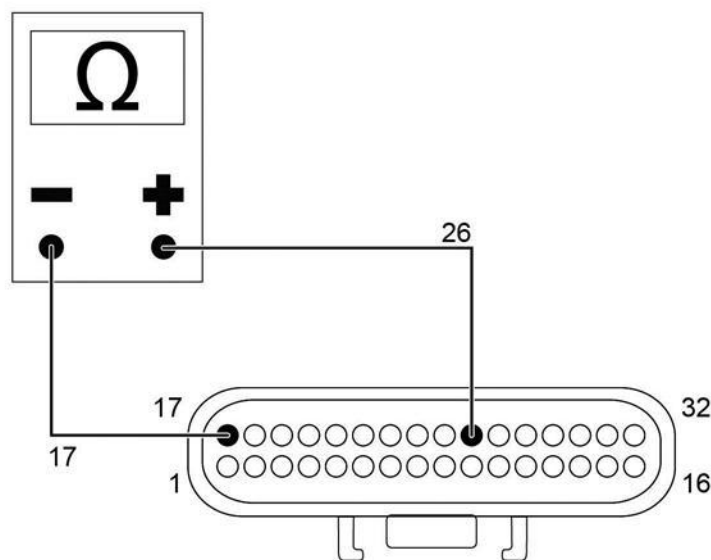

0000323341

Figure 7. 32-Way System Controller Connector Face View.

Step	Action	Decision
4	DISCHARGE TEMPERATURE SENSOR CHECK:	Yes. Leave 32-way system controller connector disconnected and go to Step 5.
	<p>A. Use a temperature probe from an A/C machine or a digital thermometer to measure the ambient temperature in the area of the discharge temperature sensor. Record the temperature.</p> <p>B. Use a DMM to measure resistance between Pin-26 and Pin-17 of the 32-way system controller connector</p> <p>C. Locate the temperature value recorded from step 4.a on the Sensor Temperature Resistance Relationship Chart.</p> <p>D. Compare the measured resistance to the min – max range on the chart.</p> <p>Does the measured resistance fall within the min-max range on the chart?</p>	No. Connect 32-way system controller connector and go to Step 41.

Discharge Sensor / Air Inlet Sensor Temperature Resistance Relationship Chart

Resistance values in Kohms.

Temp (°F)	Temp (°C)	MIN	KΩ	MAX
32.0	0	15.84		16.16
33.8	1	15.05		15.37
35.6	2	14.30		14.62
37.4	3	13.60		13.91
39.2	4	12.93		13.24
41.0	5	12.30		12.61
42.8	6	11.70		12.01
44.6	7	11.14		11.45
46.4	8	10.61		10.91
48.2	9	10.10		10.40
50.0	10	9.62		9.91
51.8	11	9.17		9.46
53.6	12	8.74		9.02
55.4	13	8.34		8.61
57.2	14	7.95		8.22
59.0	15	7.58		7.85
60.8	16	7.24		7.50
62.6	17	6.91		7.17

64.4	18	6.60		6.85
66.2	19	6.30		6.55
68.0	20	6.02		6.26
69.8	21	5.75		5.99
71.6	22	5.50		5.73
73.4	23	5.26		5.48
75.2	24	5.03		5.25
77.0	25	4.81		5.03
78.8	26	4.60		4.81
80.6	27	4.41		4.61
82.4	28	4.22		4.42
84.2	29	4.04		4.23
86.0	30	3.87		4.06
87.8	31	3.71		3.89
89.6	32	3.55		3.73
91.4	33	3.41		3.58
93.2	34	3.26		3.44
95.0	35	3.13		3.30
96.8	36	3.00		3.17
98.6	37	2.88		3.04
100.4	38	2.76		2.92
102.2	39	2.65		2.81
104.0	40	2.55		2.70
105.8	41	2.45		2.59
107.6	42	2.35		2.49
109.4	43	2.26		2.39

111.2	44	2.17		2.30
113.0	45	2.09		2.21
114.8	46	2.00		2.13
116.6	47	1.93		2.05
118.4	48	1.85		1.97
120.2	49	1.78		1.91

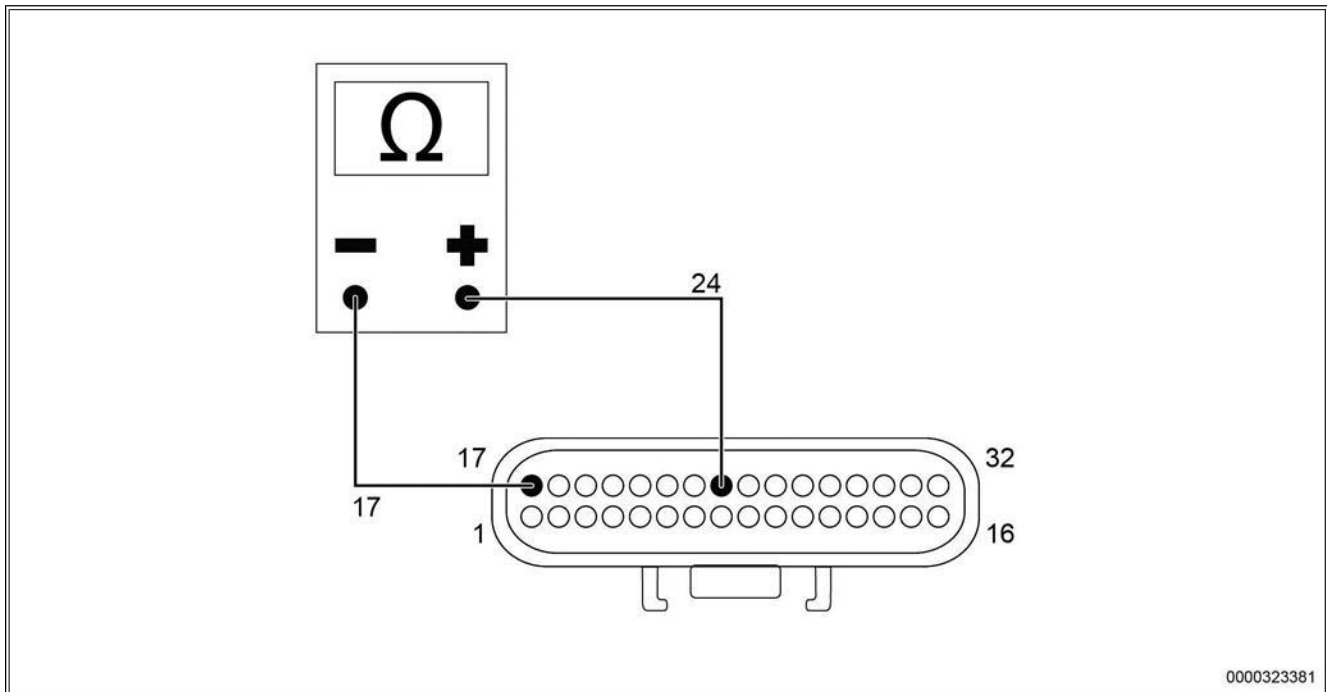
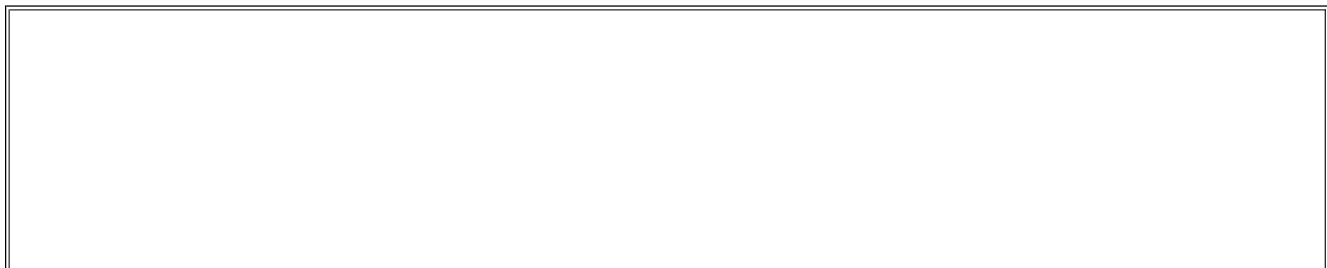
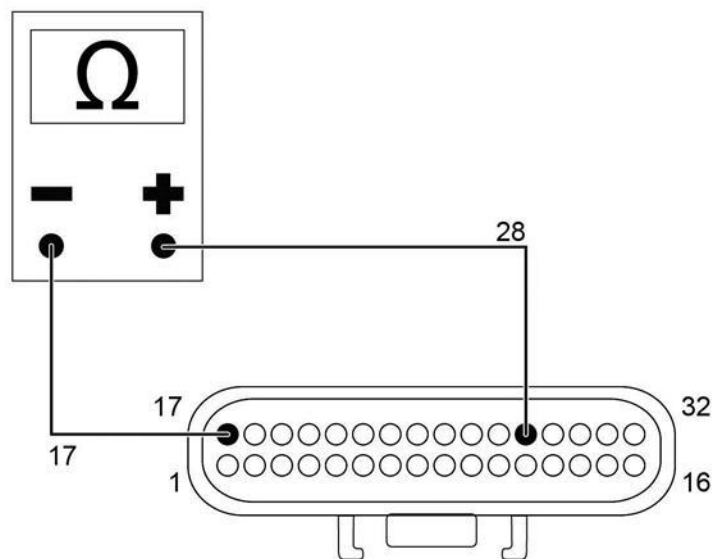

Figure 8. 32-Way System Controller Connector Face View.

Step	Action	Decision
5	INLET TEMPERATURE SENSOR CHECK: A. Use a temperature probe from an A/C machine or a thermometer to measure the ambient temperature in Celsius in the area of the inlet temperature sensor. Record the temperature. B. Use a DMM to measure resistance between system controller Pin-24 and Pin-17. C. Locate temperature value recorded from step 5.a on the Sensor Temperature Resistance Relationship Chart. D. Compare the measured resistance to the min – max range on the chart. Does the measured resistance fall within the min-max range on the chart?	Yes. Leave 32-way system controller connector disconnected and go to Step 6.
		No. Connect 32-way system controller connector and go to Step 39.





0000323401

Figure 9. 32-Way System Controller Connector Face View.

Step	Action	Decision
6	PRESSURE SWITCH CONTINUITY CHECK: A. Use a DMM to check continuity between Pin-17 and Pin-28 of the system controller connector. Is there continuity between Pin-17 and Pin-28?	Yes. Connect 32-way system controller connector and go to Step 7.
		No. Leave 32-way system controller connector disconnected and go to Step 40.

Step	Action	Decision
7	BLOWER OPERATION CHECK: A. Turn ignition Key- Off and depress the COOL-Switch to start the No-Idle A/C. B. Depress the speed-up and speed down switch to vary blower speed. Does the Evaporator Blower operate and change speeds as commanded?	Yes. Turn Off No-Idle unit and go to Step 8.
		No. Blower does not operate: Go to Step 23.
		No. Blower operates but control panel switch does not raise or lower blower speed: Go to IK1900238 - Symptom 4: No-Idle HVAC Digital Display Inoperative.

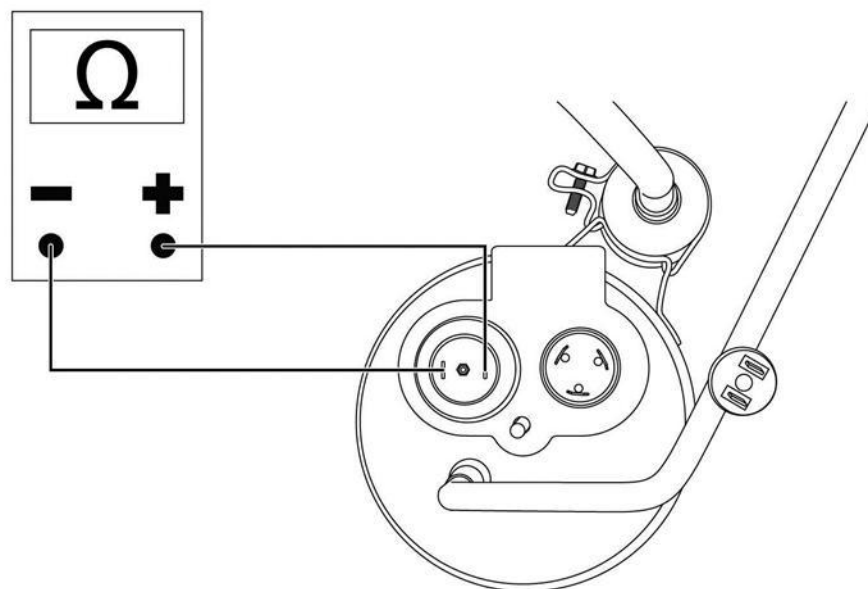

0000329221

Figure 10. Thermal Limit Switch.

Step	Action	Decision
8	<p>THERMAL LIMIT SWITCH CHECK:</p> <p>A. Remove the compressor controller cover.</p> <p>B. Remove the nut and the plastic cover over the thermal switch and the compressor harness connector.</p> <p>C. Unplug the two wires from the thermal switch and inspect the wires for damage.</p> <p>D. Use a DMM to check for continuity between the two switch terminals.</p>	<p>Yes, and thermal switch wires are not damaged: Assemble components and then go to step 9.</p>
	<p>Is there continuity between the two switch terminals?</p>	<p>Yes, but one or both of the thermal switch wires are damaged causing an open circuit: Replace the compressor controller. Assemble unit to run and retest for operator concern.</p>
		<p>No. Continuity is not present between thermal limit switch terminals: Allow thermal limit switch to cool and then retest. If switch is closed after cooling period, check for proper air flow through condenser fan grille and for debris stopping air flow around compressor. If restrictions do not exist, replace thermal limit switch.</p>

Does compressor and condenser fan cycle off when temperature setting is raised to higher levels?

No. Air temperature is cold, but digital display does not change: Shut No-Idle unit off and perform Symptom 3, Control Panel Inoperative.

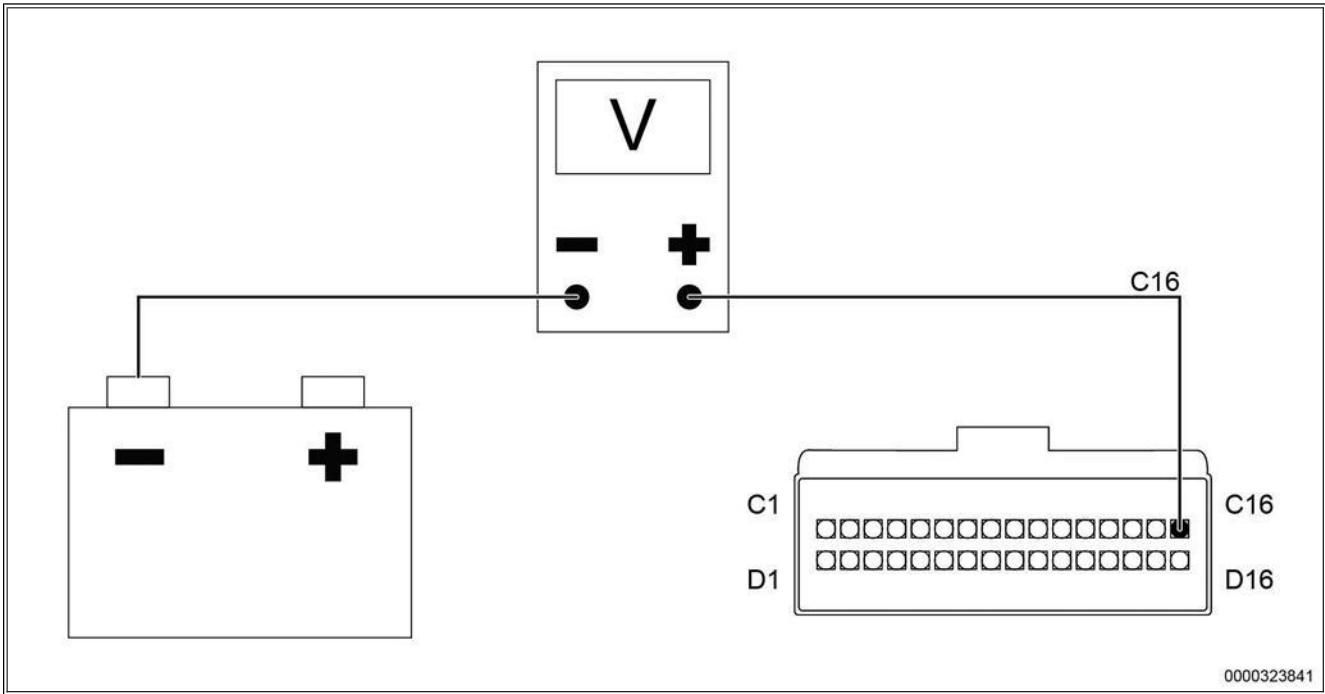
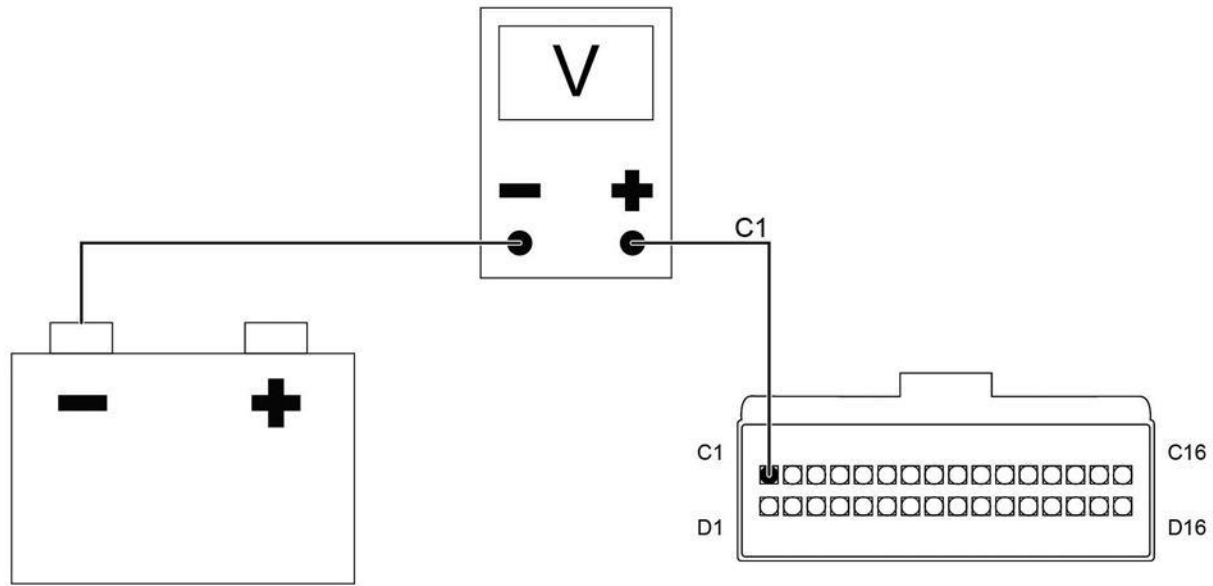

Figure 12. 32-Way Compressor Controller Connector Back View.

Step	Action	Decision
12	<p>COMPRESSOR SPEED SIGNAL CHECK:</p> <p>a. Depress digital display temperature-down switch to coldest setting.</p> <p>b. Use a DMM to back probe 32-way compressor controller connector and measure voltage between pin-C16 and a known good ground (Figure 12).</p> <p>Is voltage between 3.2V and 3.9V?</p>	<p>Yes. Leave No-Idle unit running and go to Step 13.</p> <p>No. Shut No-Idle unit off and go to Step 16.</p>



0000323781

Figure 13. 32-Way Compressor Controller Connector Back View.

Step	Action	Decision
13	COMPRESSOR CONTROLLER LOW AMP PWR CHECK: a. Use a DMM to back probe 32-way compressor controller connector and measure voltage between pin-C1 and a known good ground (Figure 13). Is there B+ at Pin-C1?	Yes. Shut No-Idle unit off and go to Step 14.
		No. Leave No-Idle unit running and go to Step 17.

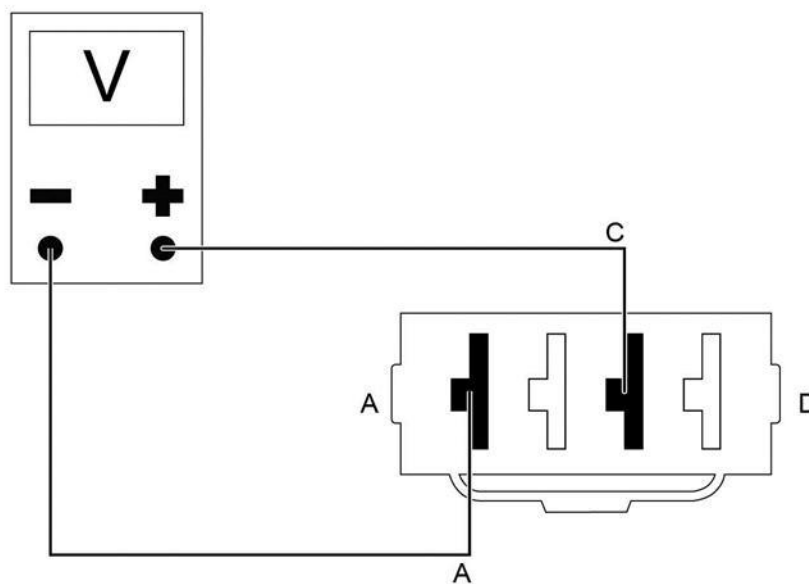

0000323821

Figure 14. 4-Way Compressor Harness Connector Back View.

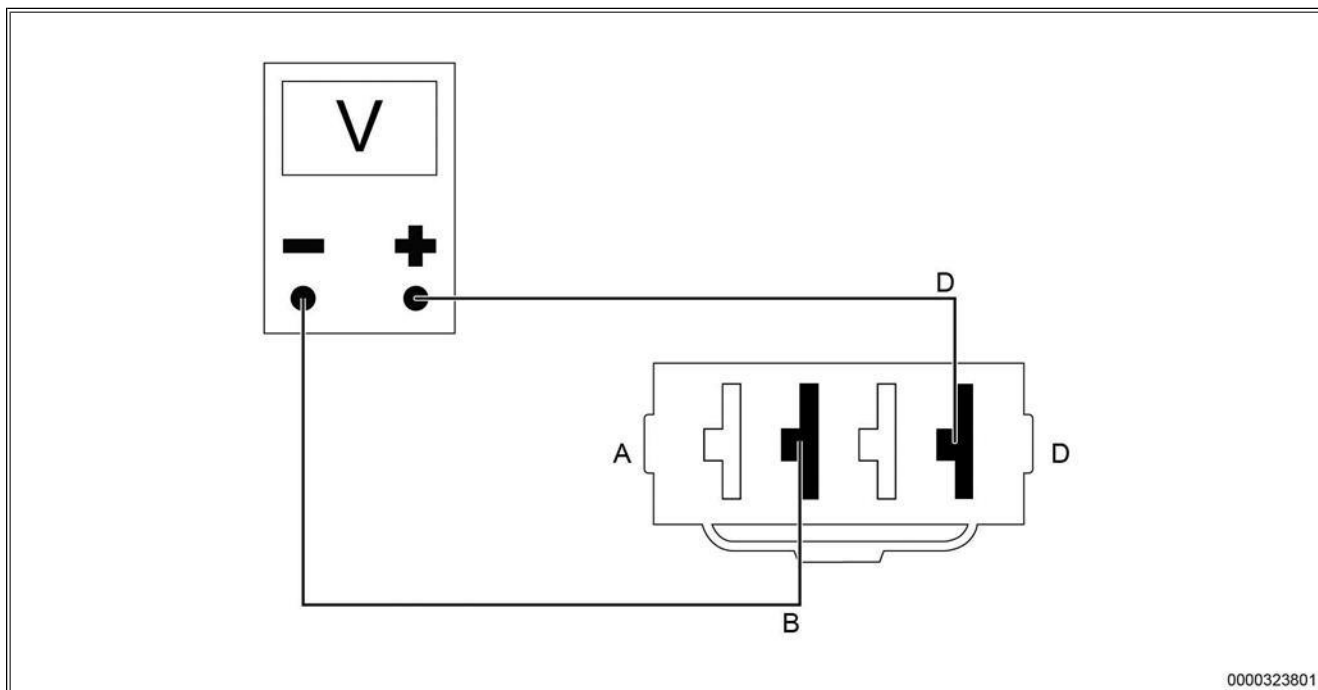

0000323801

Figure 15. 4-Way Compressor Harness Connector Back View.

Step	Action	Decision
14	<p>COMPRESSOR CONTROLLER HIGH LOW AMP PWR / GND CHECK:</p> <p>A. Unplug the compressor high amperage 4-way PWR/GND connectors.</p> <p>B. Inspect connectors for overheated plastic connector body, damaged insulation, and loose connections.</p> <p>C. Use a DMM to measure the voltage between Pin-A and Pin-C, and between Pin-B and Pin-D of the connector.</p> <p>D. Reassemble 4-way connectors</p>	<p>Yes. Reconnect the 4-way compressor controller PWR/GND connectors and then go to step 15.</p>
	<p>Is B+ voltage at 4-way compressor connector pin-C and pin-D? Are connectors and insulation in good condition?</p>	<p>No. Check Blue 60A compressor fuse (F2). * Check relay R1 (70A). Check battery box cube fuse (60A). Check for high resistance or open circuit in ground side circuits.</p> <p>Overheated connectors or wire insulation require update to 150A compressor relay and battery cables.</p> <p>* Vehicles built with, or updated to, 150A compressor relay do not use fuse (F2). Circuit protection is provided by cube fuse located in battery box and 150A relay located in heater core area of No-Idle housing.</p>

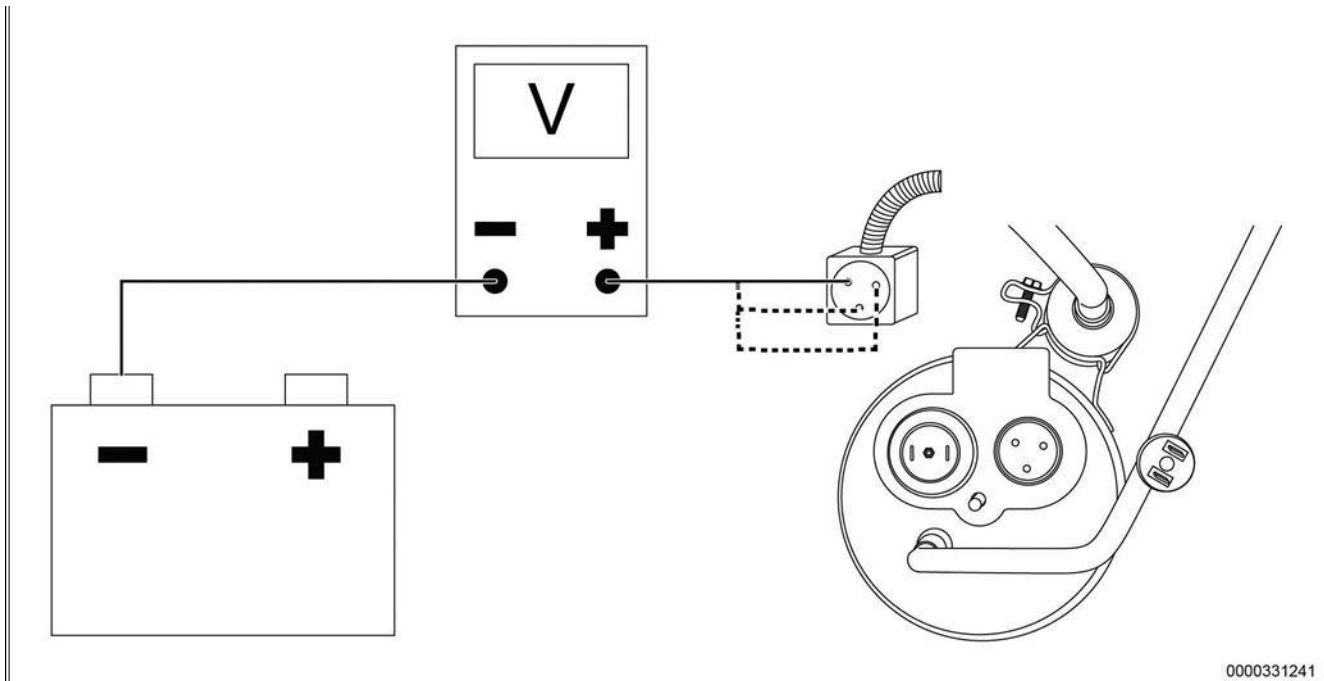

0000331241

Figure 16. 3-Way Compressor Connector.

CAUTION:

To prevent damage to components, do not attempt to connect battery voltage to evaporator blower motor, condenser fan motor, or A/C compressor. Electronic components within the motors are sensitive to arcing and reverse polarity.

Step	Action	Decision
15	<p>COMPRESSOR CONTROLLER OUTPUT CHECK:</p> <ul style="list-style-type: none"> a. Stop No-Idle unit. b. Remove compressor controller cover. c. Disconnect compressor controller harness 3-way connector from compressor. d. Turn ignition Key-Off and depress COOL switch to start No-Idle A/C. e. Depress digital display Temp switch to coldest setting. f. When the condenser fan starts, Use a DMM to measure voltage between compressor controller harness 3-way connector power wire and a known good ground. g. Repeat Step 15.F for remaining two wires. <p>Is the voltage between 5 - 6V ? Is the voltage correct on all three wires?</p>	<p>Yes. Replace the refrigerant component. Assemble unit to run and retest for operator concern.</p>
		<p>No. Replace compressor controller. Assemble unit to run and retest for operator concern.</p>

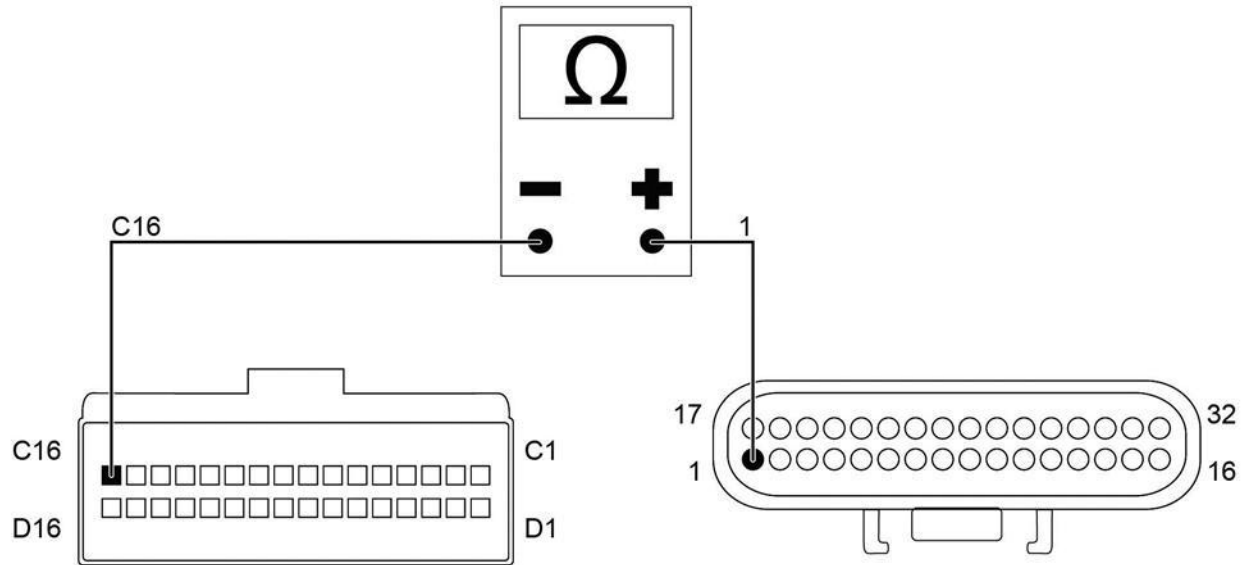

0000323501

Figure 17. 32-Way Compressor Controller Connector Face View and 32-Way System Controller Connector Face View.

Step	Action	Decision
16	<p>COMPRESSOR SPEED SIGNAL CIRCUIT CHECK:</p> <p>a. Stop No-Idle unit.</p> <p>b. Disconnect 32-way compressor controller connector from compressor controller.</p> <p>c. Disconnect 32-way system controller connector from system controller.</p> <p>d. Use a DMM to check continuity between 32-way system controller connector pin-1 and 32-way compressor controller connector pin-C16 (Figure 17).</p> <p>e. Use a DMM to check resistance between 32-way compressor controller connector pin-C16 and a known good ground (Figure 17).</p> <p>Is Step 16.d measurement less than 5 Ohms and Step 16.e greater than 1000 Ohms?</p>	<p>Yes. Replace system controller. Assemble unit to run and retest for operator concern.</p>
		<p>No. Replace No-Idle harness. Assemble unit to run and retest for operator concern.</p>

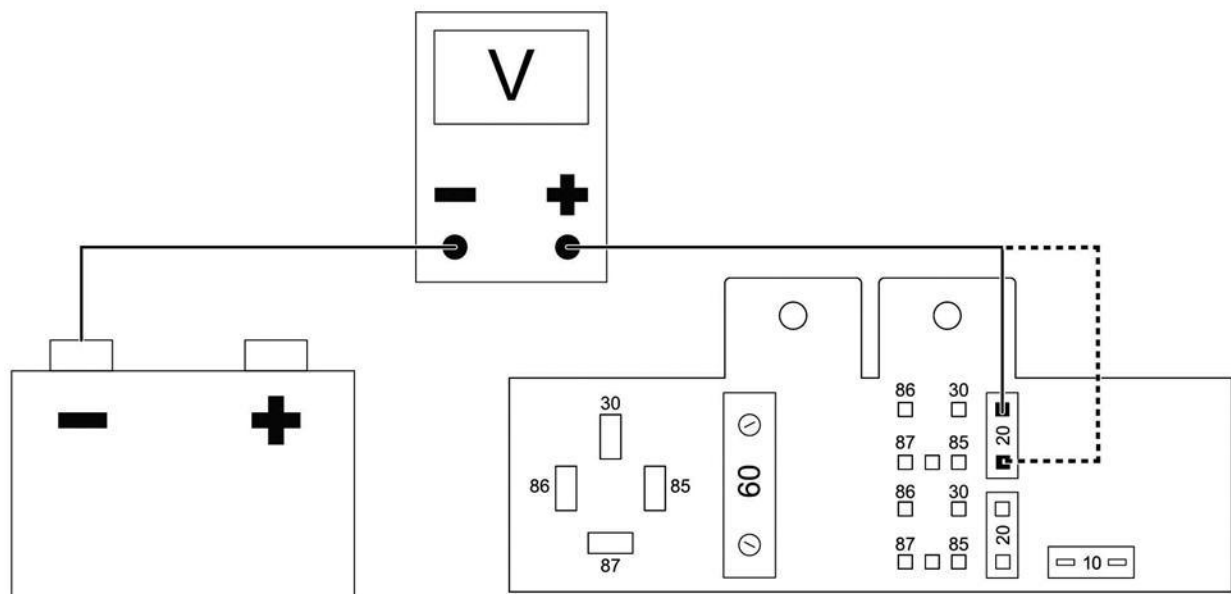

0000329281

Figure 18. Blower Fuse (F5).

Step	Action	Decision
17	<p>COMPRESSOR CONTROLLER LOW AMP PWR CIRCUIT CHECK:</p> <p>a. Check for B+ on each side of yellow 20A blower fuse (F5)</p> <p>Does Yellow 20A blower fuse (F5) have B+ on both sides?</p>	<p>Yes. Replace No-Idle harness. Assemble unit to run and retest for operator concern.</p>
		<p>No. If Yellow blower fuse (F5) is good, check pin-A7 and pin-A8 of 30-way chassis / No-Idle harness connector for pushed back pins. Check cube fuse.</p>
		<p>No. If Yellow blower fuse (F5) is replaced and it blows again, go to Step 43.</p>

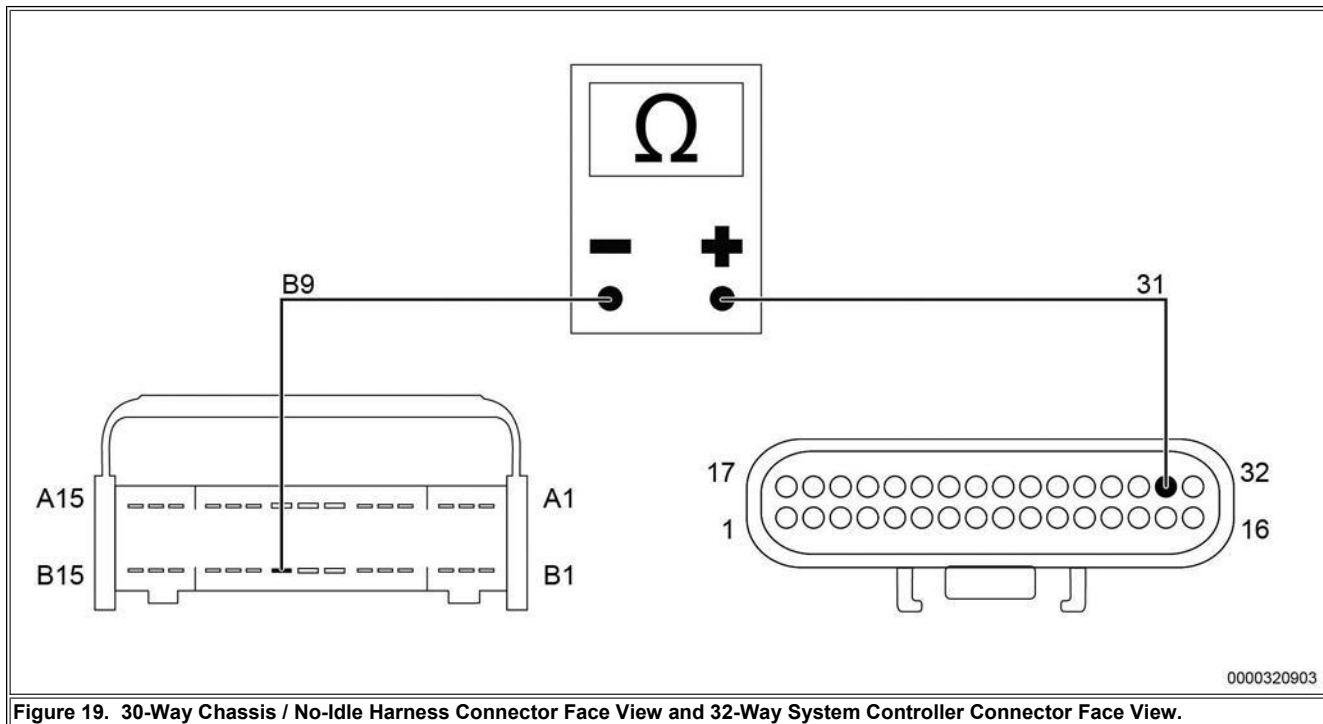
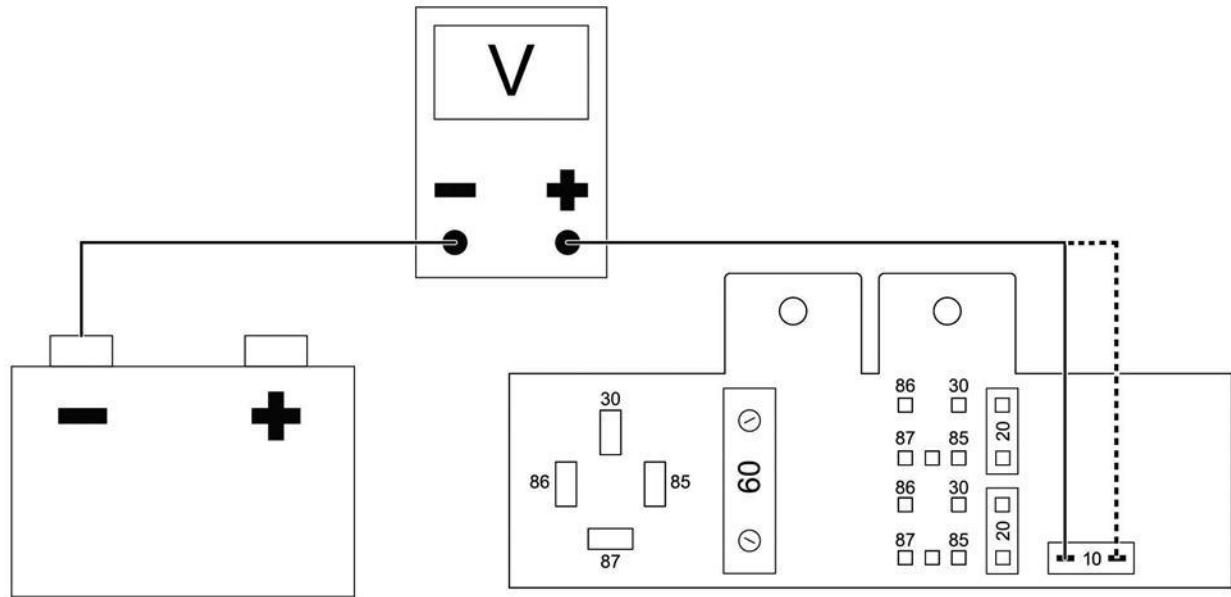

Figure 19. 30-Way Chassis / No-Idle Harness Connector Face View and 32-Way System Controller Connector Face View.

Step	Action	Decision
18	<p>SYSTEM CONTROLLER GND CHECK:</p> <p>a. Stop No-Idle unit.</p> <p>b. Disconnect 30-way chassis / No-Idle harness connector (5205).</p> <p>c. Use a DMM to check continuity between 32-way system controller harness connector pin-31 and 30-way chassis / No-Idle harness connector (5205) pin-B9 (Figure 19).</p> <p>Is continuity between pin-31 and pin-B9?</p>	<p>Yes. Check continuity between 30-way connector 5205 Pin-B9 and battery ground. Repair or replace chassis harness as needed. Reassemble unit to run and retest for operator concern.</p>
		<p>No. Replace No-Idle harness. Assemble unit to run and retest for operator concern.</p>



0000329261

Figure 20. 10A Fuse (F7).

Step	Action	Decision
19	<p>SYSTEM CONTROLLER PWR CHECK:</p> <p>a. Use a DMM to measure voltage on each side of Red 10A fuse (F7) (Figure 20).</p> <p>Does Red 10A fuse (F7) have B+ on both sides?</p>	<p>Yes. Replace No-Idle harness. Assemble unit to run and retest for operator concern.</p>
		<p>No. Go to Step 44.</p>

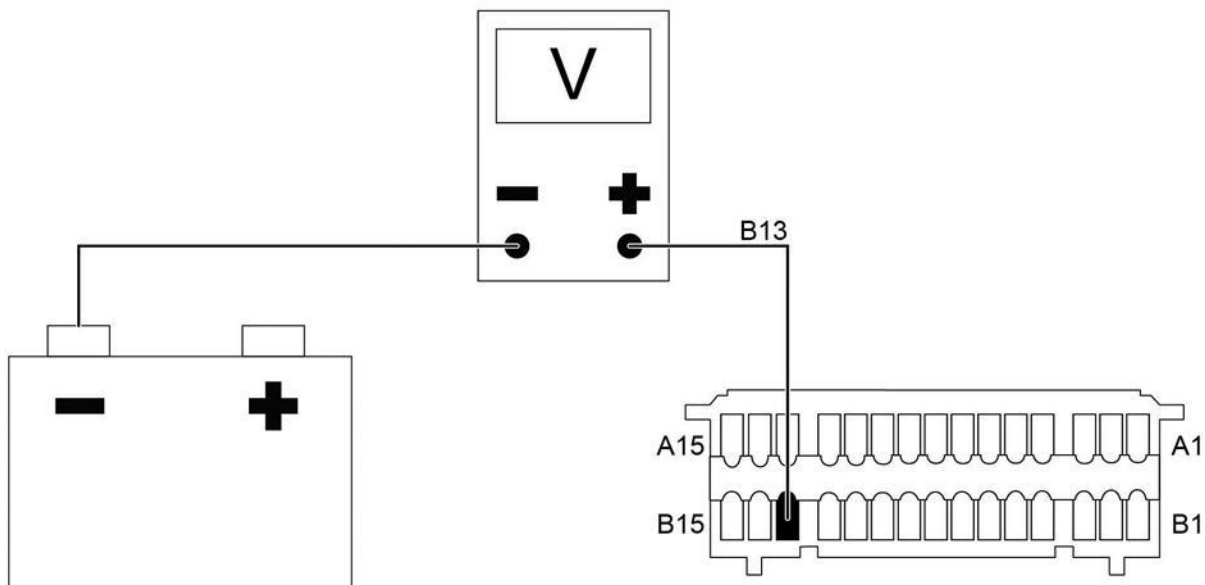

0000323862

Figure 21. 30-Way Chassis / No-Idle Harness Connector (5205) Side Back View.

Step	Action	Decision
20	CONTROLLER COOL SWITCH INPUT CHECK: a. Stop No-Idle unit. b. Use a DMM to back probe chassis side of 30-way chassis / No-Idle harness connector (5205) pin-B13 while holding control panel COOL switch depressed (Figure 21).	Yes. Replace No-Idle harness. Assemble unit to run and retest for operator concern.
	Does Pin B13 have B+ when the cool switch is depressed?	No. Go to Step 21.

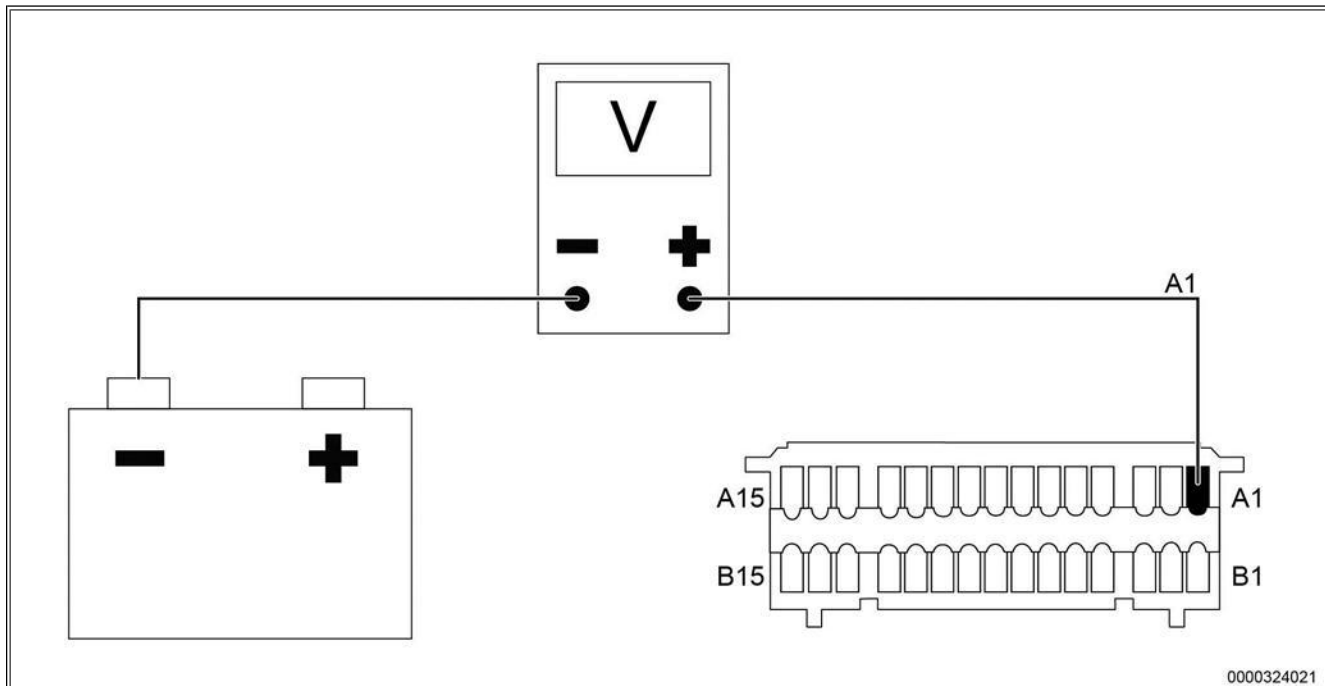

0000324021

Figure 22. 30-Way Chassis / No-Idle Harness Connector (5205) Chassis Side Back View.

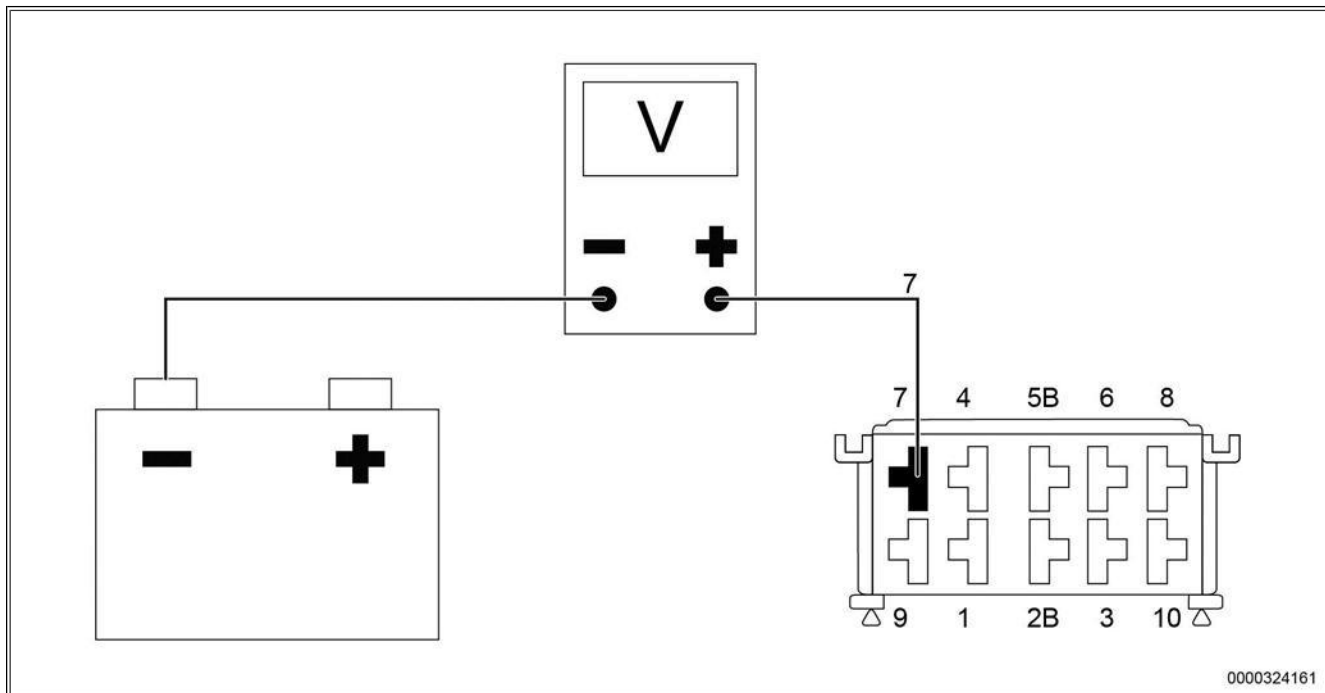

0000324161

Figure 23. COOL Rocker Switch Back View.

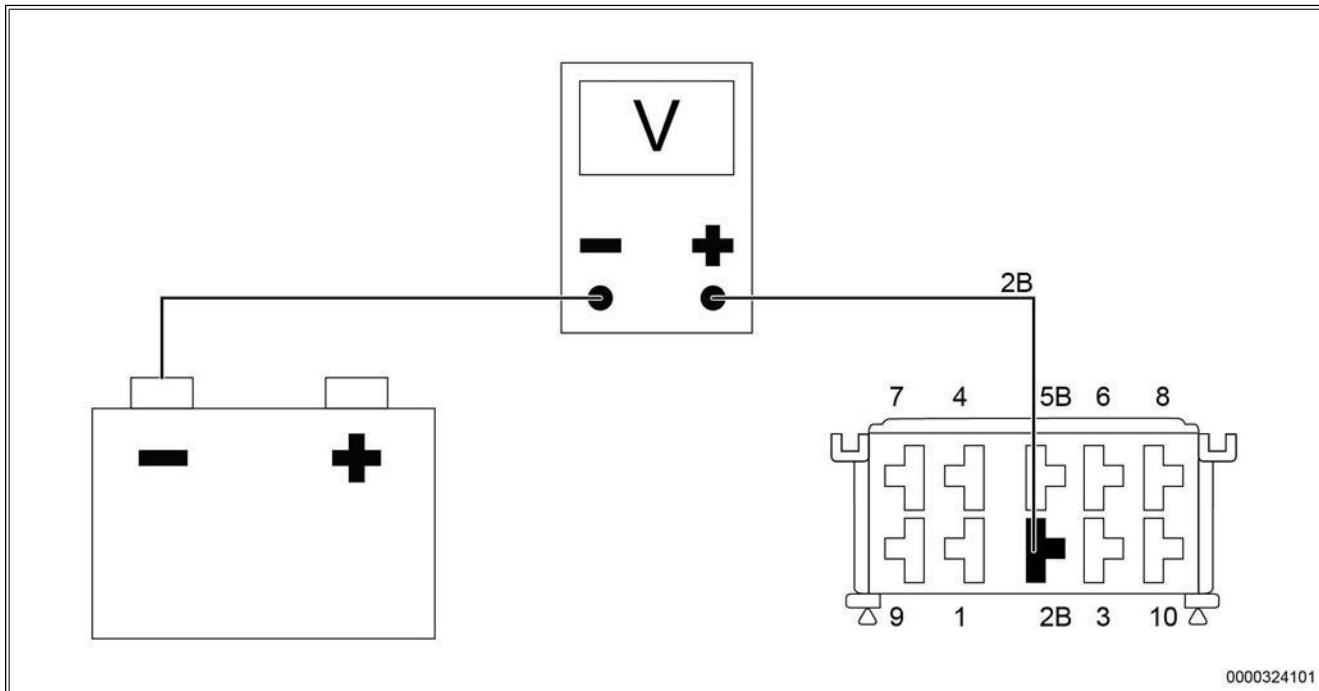

0000324101

Figure 24. COOL Rocker Switch Back View.

Step	Action	Decision								
21	COOL SWITCH CIRCUIT CHECK:	Yes. Leave connector 5205 disconnected and go to step 22.								
	A. Use a DMM to back probe the chassis/No-idle connector (5205); measure voltage between connector 5205 Pin-A1 and a known good GND.	No. Step 22.a has B+, Step 22.b has B+, and Step 22.c has <B+: Replace COOL rocker switch. Assemble unit to run and retest for operator concern.								
	B. Use a DMM to back probe the COOL rocker switch; measure voltage between COOL Pin-7 and a known good GND.	No. Step 22.a has B+, Step 22.b and Step 22.c have <B+: Circuit is open between 30-way chassis / No-Idle harness connector (5205) pin-A1 and COOL rocker switch pin-7. Repair as needed. Assemble unit to run and retest for operator concern.								
	C. Use a DMM to back probe the No-Idle rocker switch; measure voltage between COOL No-Idle rocker switch Pin-2B and a known good GND as the switch is held DEPRESSED.	No. Steps 22.a through 22.c have <B+: Check Red 10A controller fuse (F7)*. Check continuity from Red 10A controller fuse (F7) to 30-way chassis / No-Idle harness connector (5205) pin-A1 for an open. If circuit is open, replace No-Idle harness.								
	Record measurements									
	<table border="1"> <thead> <tr> <th>Step</th> <th>22.a</th> <th>22.b</th> <th>22.c</th> </tr> </thead> <tbody> <tr> <td>Voltage</td> <td></td> <td></td> <td></td> </tr> </tbody> </table>	Step	22.a	22.b	22.c	Voltage				
Step	22.a	22.b	22.c							
Voltage										
	Are all three measurements B+?	* If Red 10A controller fuse (F7) blows, go to Step 44.								

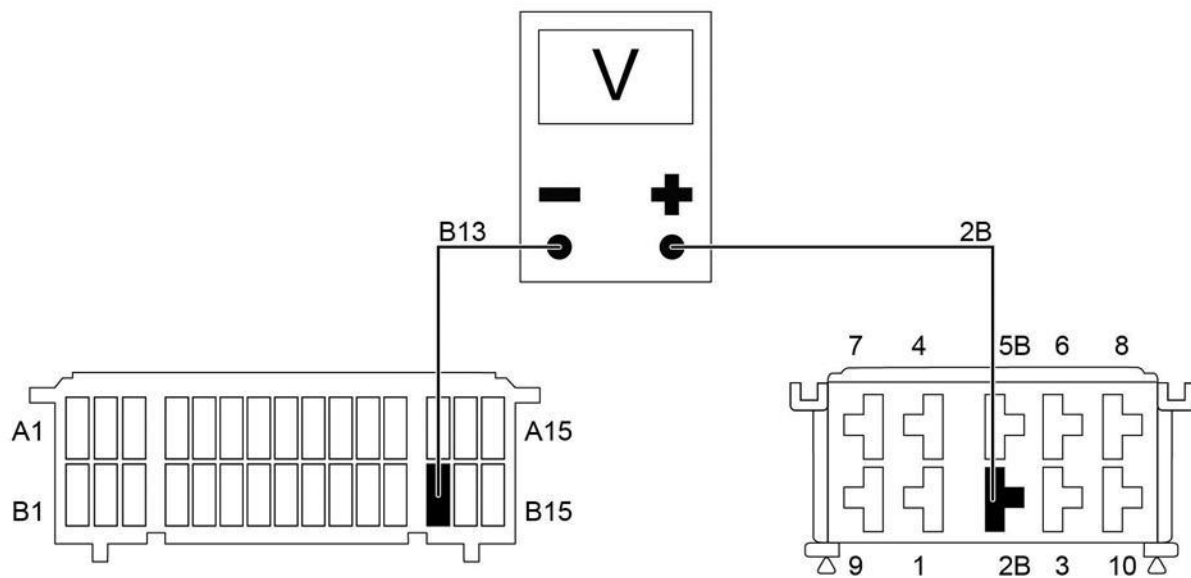

0000324201

Figure 25. 30-Way Chassis / No-Idle Harness Connector (5205) Chassis Side Face View and COOL Rocker Switch Back View.

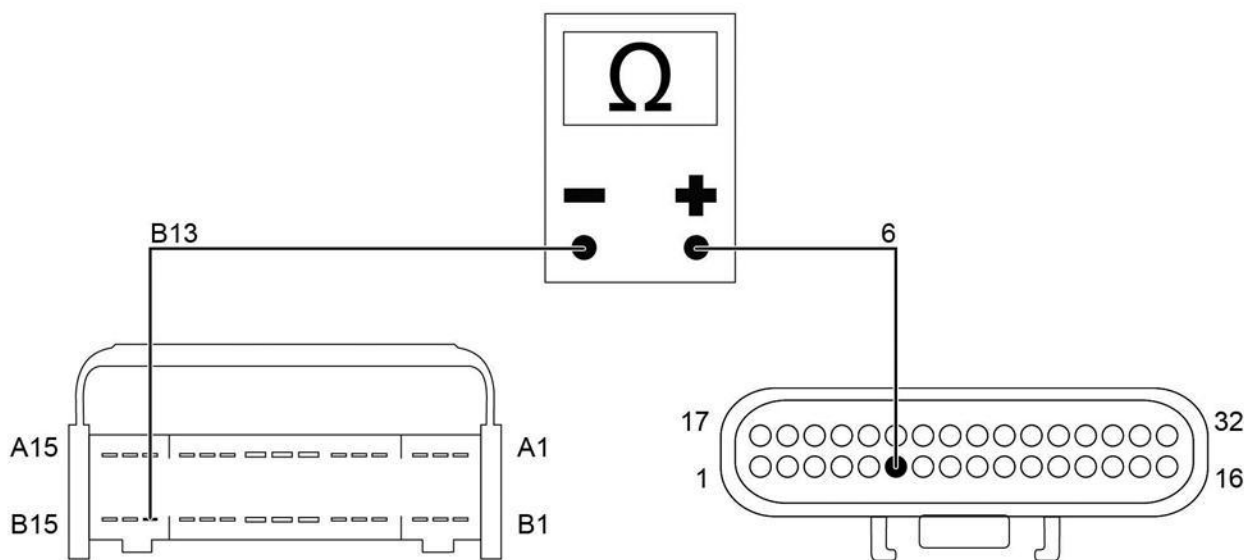

0000320961

Figure 26. 30-Way Chassis / No-Idle Harness Connector (5205) No-Idle Side Face View and 32-Way System Controller Connector Face View.

Step	Action	Decision
22	<p>COOL SWITCH SIGNAL CHECK:</p> <p>a. Stop No-Idle unit.</p> <p>b. Disconnect 32-way system controller connector.</p> <p>c. Use a DMM to check continuity between control panel COOL switch pin-2B and connector 5205 pin-B13 (Figure 25).</p> <p>d. Use a DMM to check continuity between connector 5205 pin-B13 and 32-way system controller pin-6 (Figure 26).</p>	<p>22c. Chassis Harness does not have continuity. Repair or replace chassis wiring from connector 5205 pin-B13 to control panel COOL switch pin-2B as needed. Assemble unit to run and retest for operator concern.</p> <p>22d. No-Idle Harness does not have continuity. Replace No-Idle harness. Assemble unit to run and retest for operator concern.</p>

Does Chassis harness - Cool switch pin-2B to 30-way chassis / No-Idle harness connector (5205) pin-B13 have an open circuit?

Chassis Harness		No-Idle Harness	
COOL switch	30-way Connector (5205)	30-way connector	System Controller Pin
Pin-2B	Pin-B13	Pin-B13	6

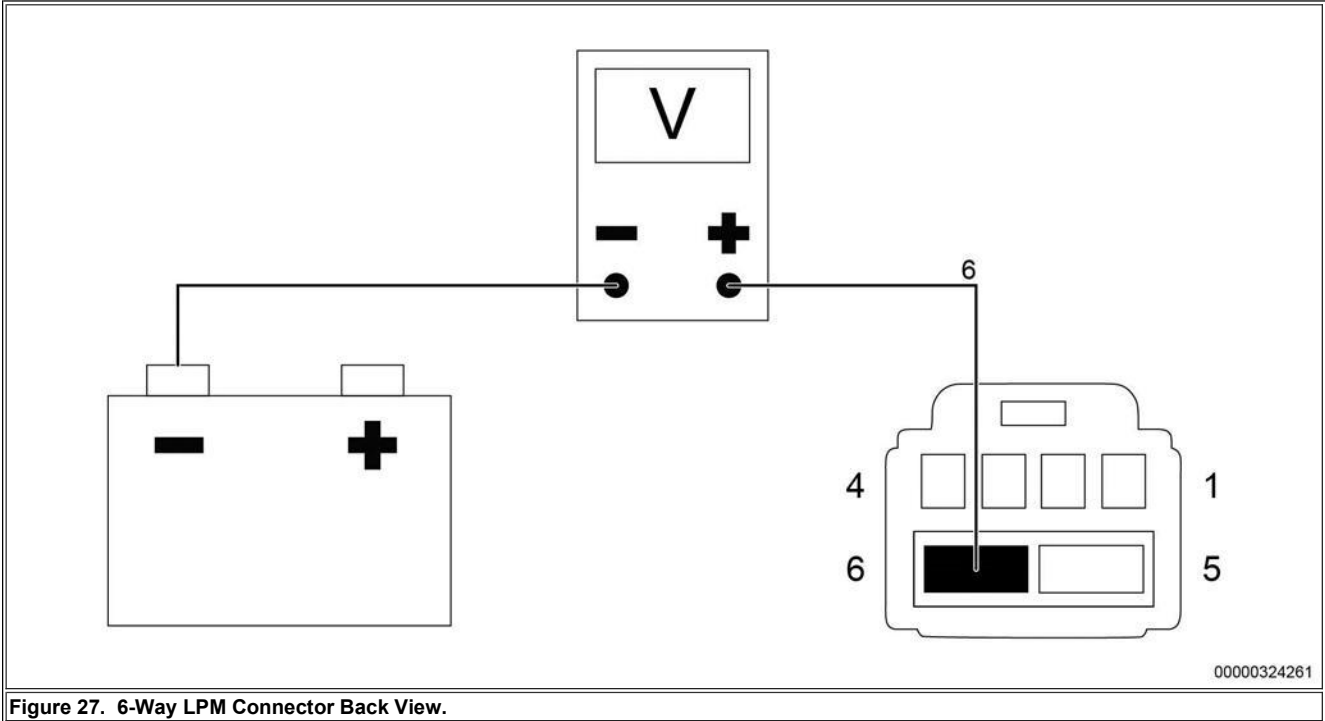

Figure 27. 6-Way LPM Connector Back View.

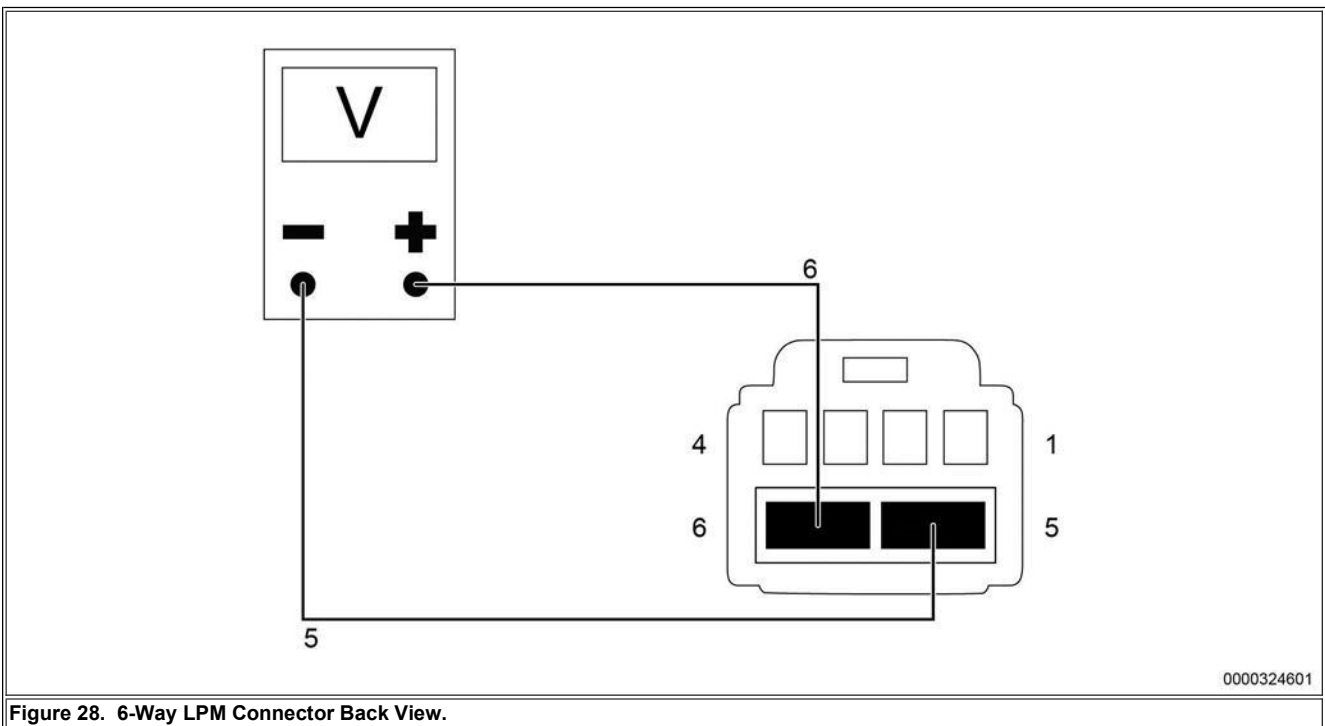
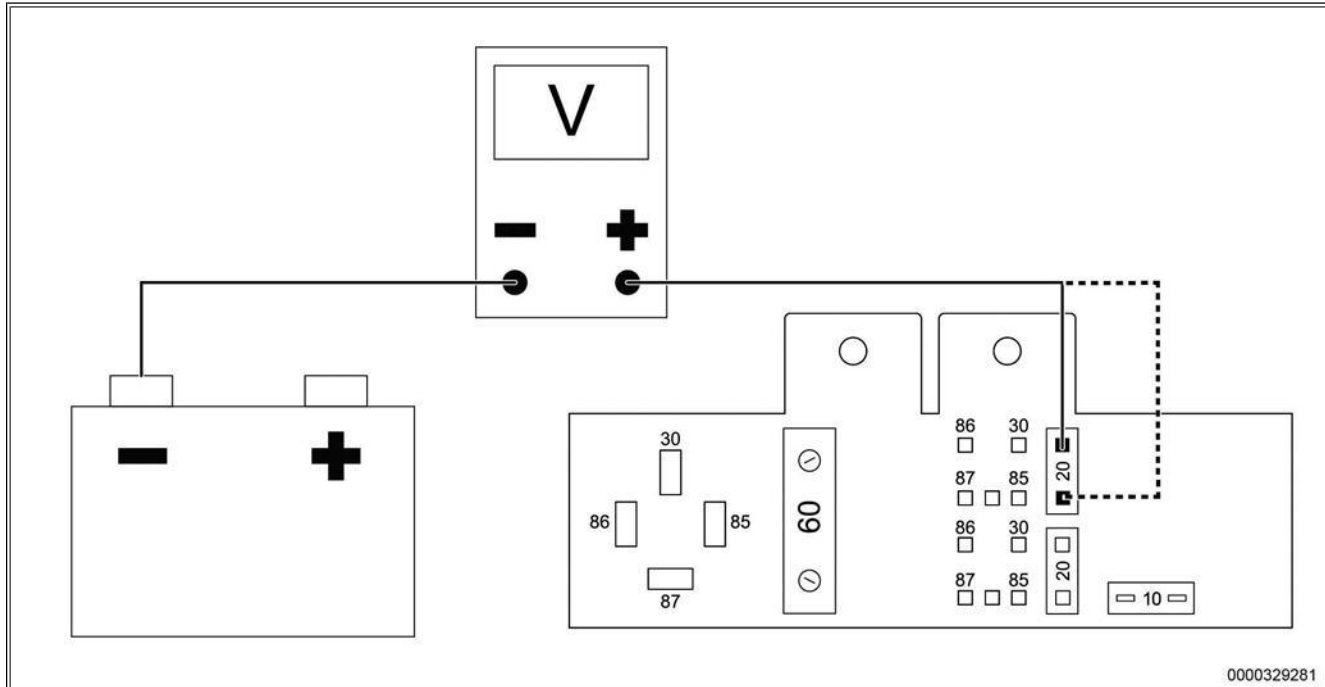

Figure 28. 6-Way LPM Connector Back View.

Step	Action	Decision
23	LPM PWR / GND CHECK:	Yes. Go to Step 26.
	a. Turn ignition Key-Off and depress control panel COOL switch to start No-Idle A/C.	No. Both Step 23.b and 23.c have less than B+ or zero volts: Go to Step 24.
	b. Use a DMM to back probe 6-way LPM connector to measure voltage between pin-6 and a known good ground (Figure 27).	
c. Use a DMM to back probe 6-way LPM connector to measure voltage between pin-5 and pin-6 (Figure 28).	No. Step 23.b has B+ but Step 23.c has less than B+ or zero volts: Go to Step 25.	
	Do Steps 23.b and 23.c both measure B+?	



0000329281

Figure 29. No-Idle Relay / Fuse Panel Blower Fuse (F5).

Step	Action	Decision
24	LPM PWR CIRCUIT CHECK:	Yes. Replace No-Idle harness as needed. Assemble unit to run and retest for operator concern.
	a. Use a DMM to measure voltage between both sides of Yellow 20A blower fuse (F5) and a known good ground (Figure 29).	No. Neither side has B+: Go to Step 42 and test relay circuits.
	Is B+ present on both sides of blower fuse (F5)?	
		No. Blower fuse (F5) blows: Go to Step 43.

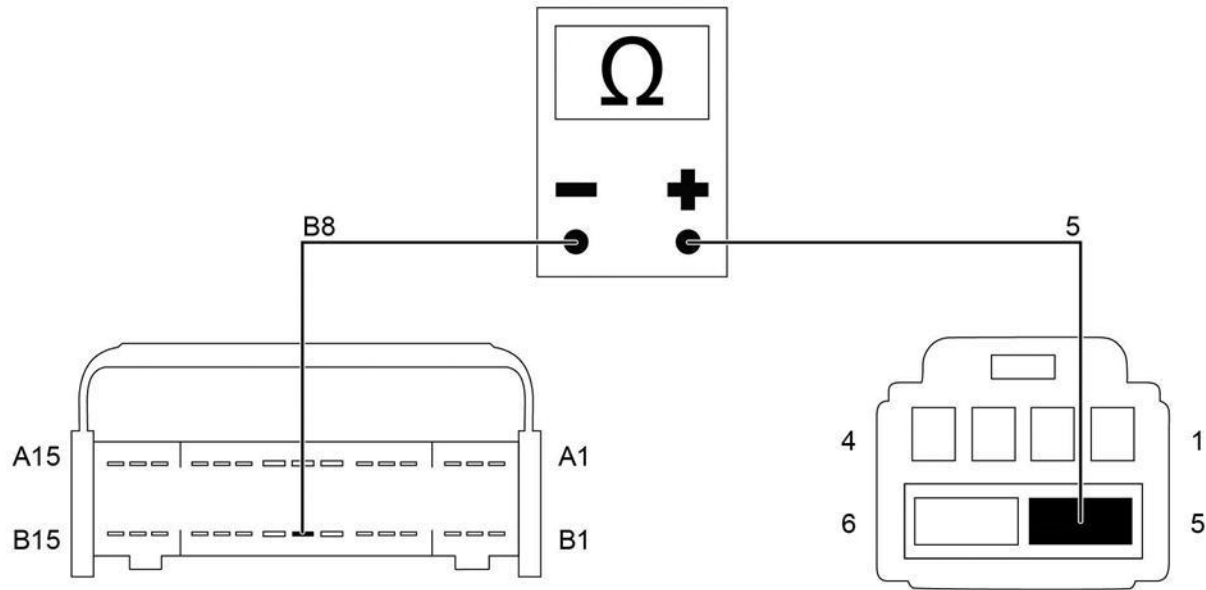

0000337361

Figure 30. Connector 5205 No-Idle Side Face View and 6-Way LPM Connector Face View.

Step	Action	Decision
25	LPM GND CIRCUIT CHECK: a. Stop No-Idle unit. b. Disconnect 6-way LPM connector. c. Disconnect 30-way chassis / No-Idle harness connector (5205). d. Use a DMM to check continuity between No-Idle side of connector 5205 pin-B8 and 6-way LPM connector pin-5 (Figure 30).	Yes. Check continuity between connector 5205 pin-B8 and battery ground terminal. Repair or replace chassis harness as needed. Assemble unit to run and retest for operator concern.
	Is continuity present pin-B8 and pin-5?	No. Replace No-Idle harness. Assemble unit to run and retest for operator concern.

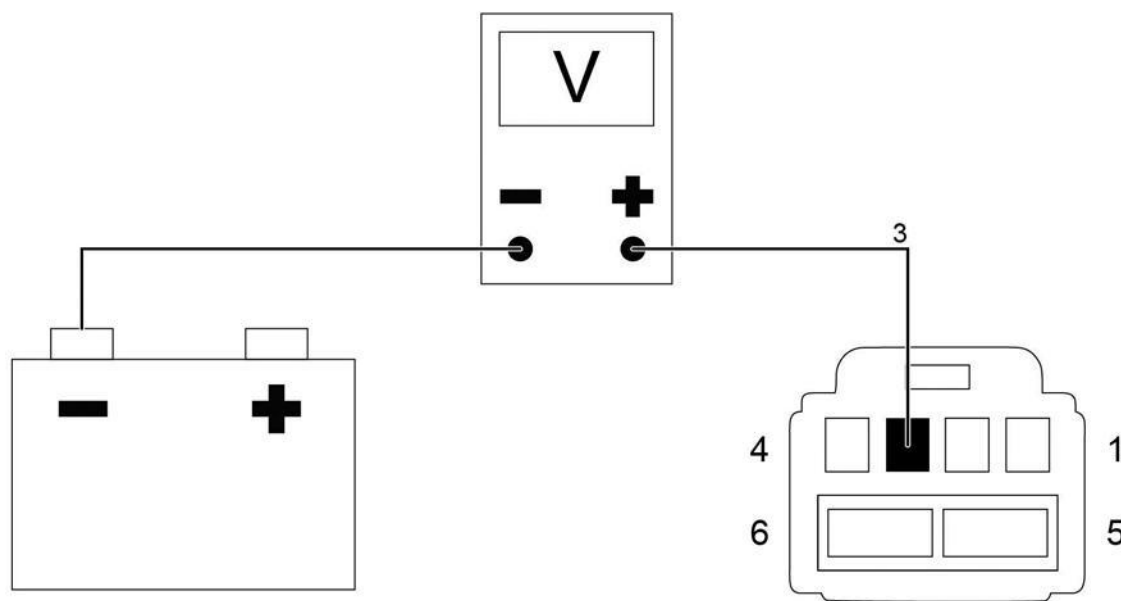

0000324721

Figure 31. 6-Way LPM Connector Back View.

Step	Action	Decision
26	<p>BLOWER SPEED SIGNAL CHECK:</p> <p>a. Turn ignition Key-Off and depress control panel COOL switch to start No-Idle A/C.</p> <p>b. Depress digital display temperature control to coldest setting.</p> <p>c. Use a DMM to back probe 6-way LPM connector and measure voltage between pin-3 and a known good ground (Figure 31).</p>	<p>Yes. Leave No-Idle unit running and go to Step 28.</p>
	<p>Is voltage between 2.5V (High Temp) and 4.5V (Low Temp)?</p>	<p>No. Shut No-Idle unit off and go to Step 27.</p>

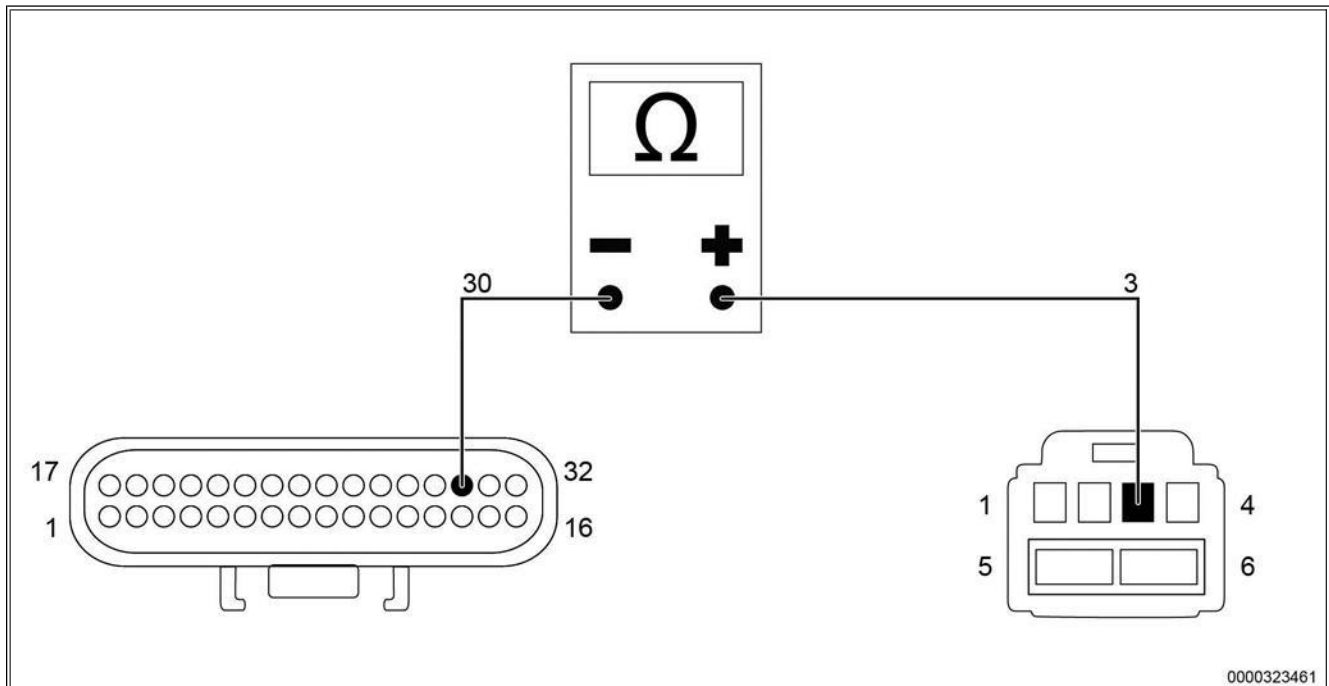

0000323461

Figure 32. 32-Way System Controller Face View and 6-Way LMP Connector Face View.

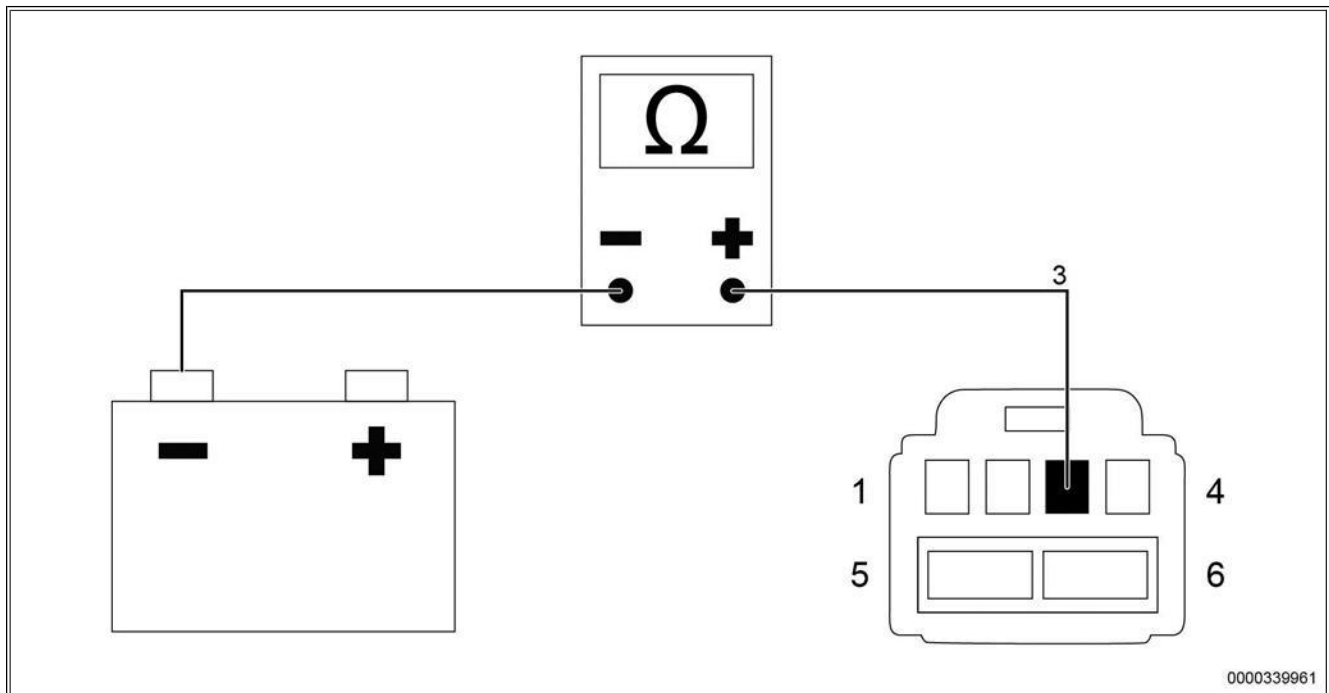

0000339961

Figure 33. 6-Way LMP Connector Face View.

Step	Action	Decision
27	BLOWER SPEED SIGNAL CIRCUIT CHECK: a. Disconnect 6-way LMP connector. b. Disconnect 32-way system controller connector. c. Use a DMM to check continuity between 6-way LMP connector pin-3 and 32-way system controller connector pin-30 (Figure 32). d. Use a DMM to check resistance between 6-way LMP connector pin-3 and a known good ground (Figure 33). Is Step 27.c measurement less than 5 Ohms and Step 27.d greater than 100 Ohms?	Yes. Replace system controller. Assemble unit to run and retest for operator concern.
		No. Replace No-Idle harness. Assemble unit to run and retest for operator concern.

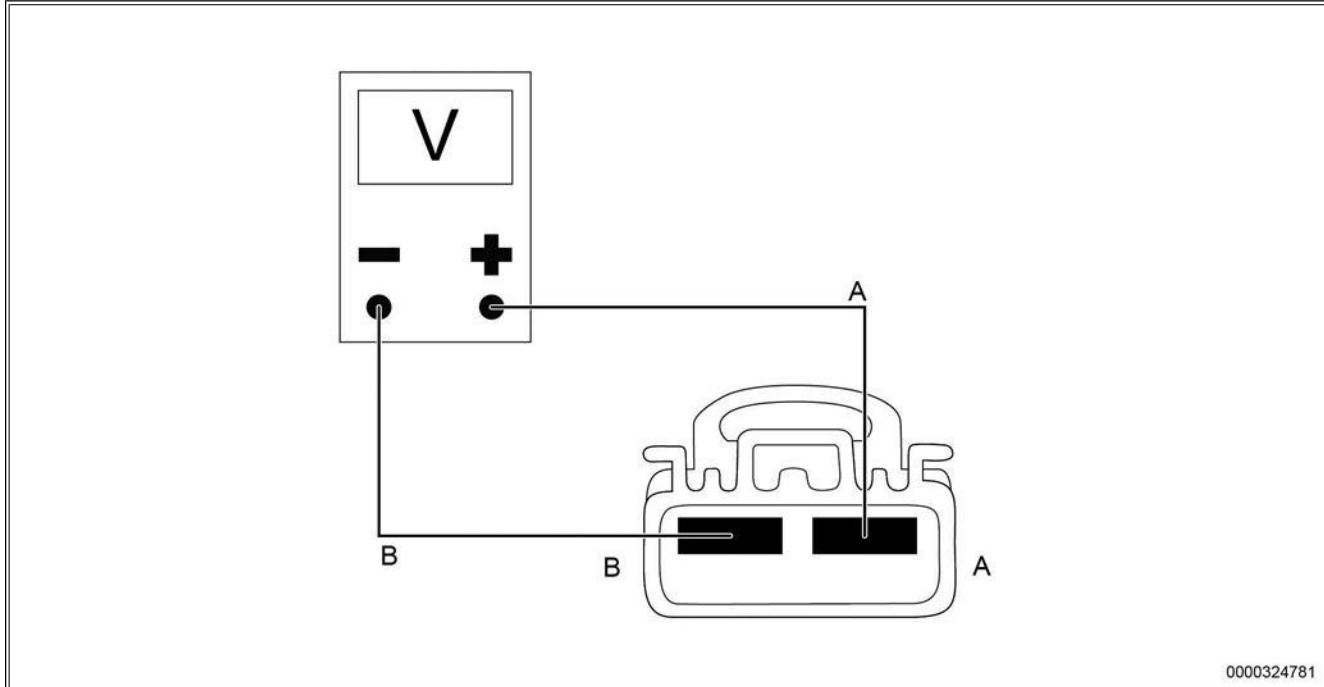

0000324781

Figure 34. 2-Way LMP Connector Back View.

CAUTION:

Do not attempt to connect an outside power source to the evaporator blower motor. Internal electronic components are sensitive to arcing and reverse polarity; damage will occur.

Step	Action	Decision
28	EVAPORATOR BLOWER SPEED SIGNAL CHECK: a. Turn ignition Key-Off and depress control panel COOL switch to start No-Idle A/C. b. Depress digital display temperature control to coldest setting. c. Verify 6-way LMP connector and 2-way LMP connector are connected. d. Use a DMM to back probe 2-way LMP connector and measure voltage between pin -1 and pin-2 (Figure 34). Is voltage between 6.5V (Lowest speed) and 10.6V (highest speed)?	Yes. Replace evaporator blower motor. Assemble unit to run and retest for operator concern.
		No. Replace LMP. Assemble unit to run and retest for operator concern.

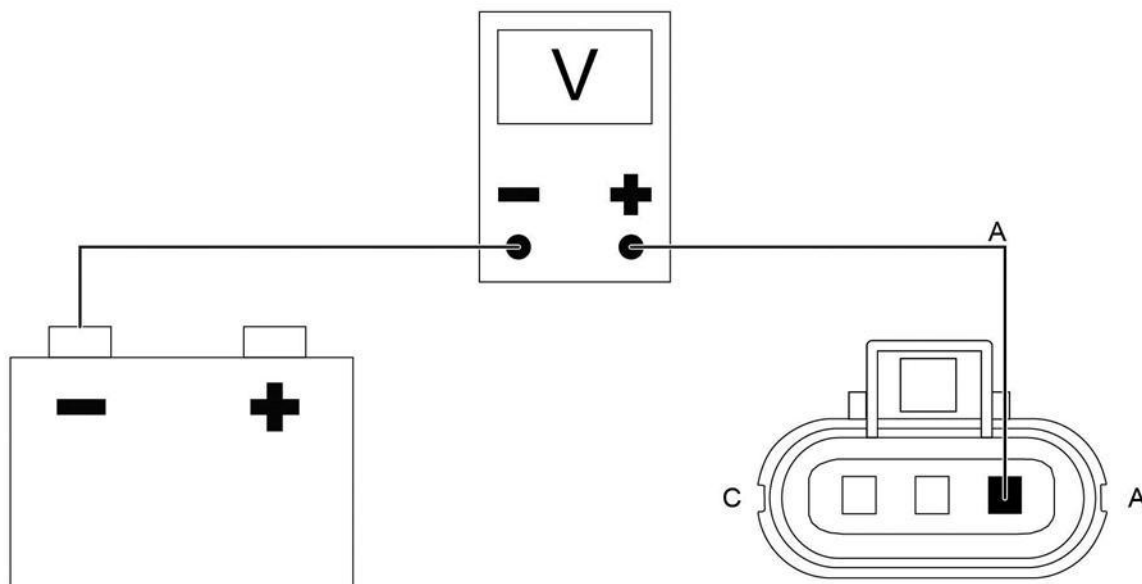

0000324801

Figure 35. Condenser Fan Harness Connector Face View.

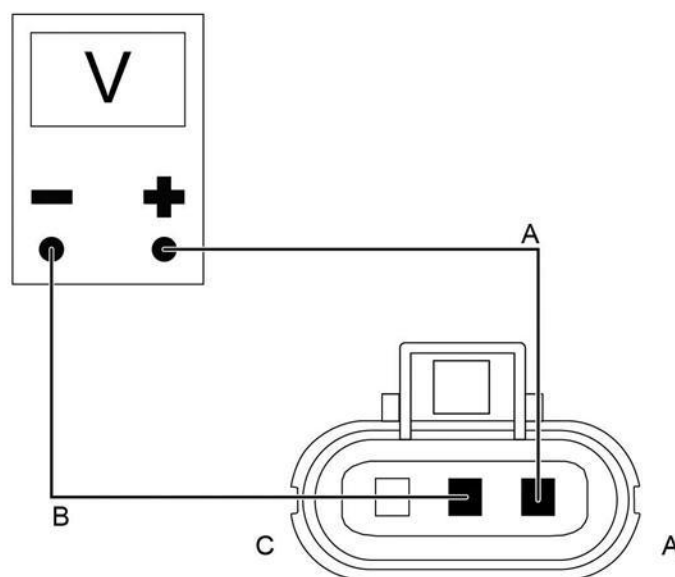

0000324841

Figure 36. Condenser Fan Motor Connector and Condenser Fan Harness Connector Face View.

Step	Action	Decision
29	CONDENSER FAN MOTOR PWR / GND CHECK:	Yes. Go to Step 30.
	a. Remove exterior fan grille. b. Disconnect condenser fan harness connector from condenser fan motor lead. c. Turn ignition Key-Off and depress control panel COOL switch to start No-Idle A/C. d. Depress digital display temperature control multiple times to coldest setting. e. Use a DMM to monitor voltage between relay side of fuse (F4) and a known good ground.	No. Both Step 29.f and 29.g voltages are zero or low: Go to Step 31.
	f. While fuse (F4) has PWR, use a DMM to measure voltage between condenser fan harness connector pin-A and a known good ground (Figure 35). g. While fuse (F4) has PWR, use a DMM to measure voltage between condenser fan harness pin-A and pin-B (Figure 36).	No. Step 2.f voltage is B+ but Step 29.g is low or zero: Replace No-Idle harness. Assemble unit to run and retest for operator concern.

Is voltage B+ in both Steps 29.f and 29.g while fuse (F4) has PWR?

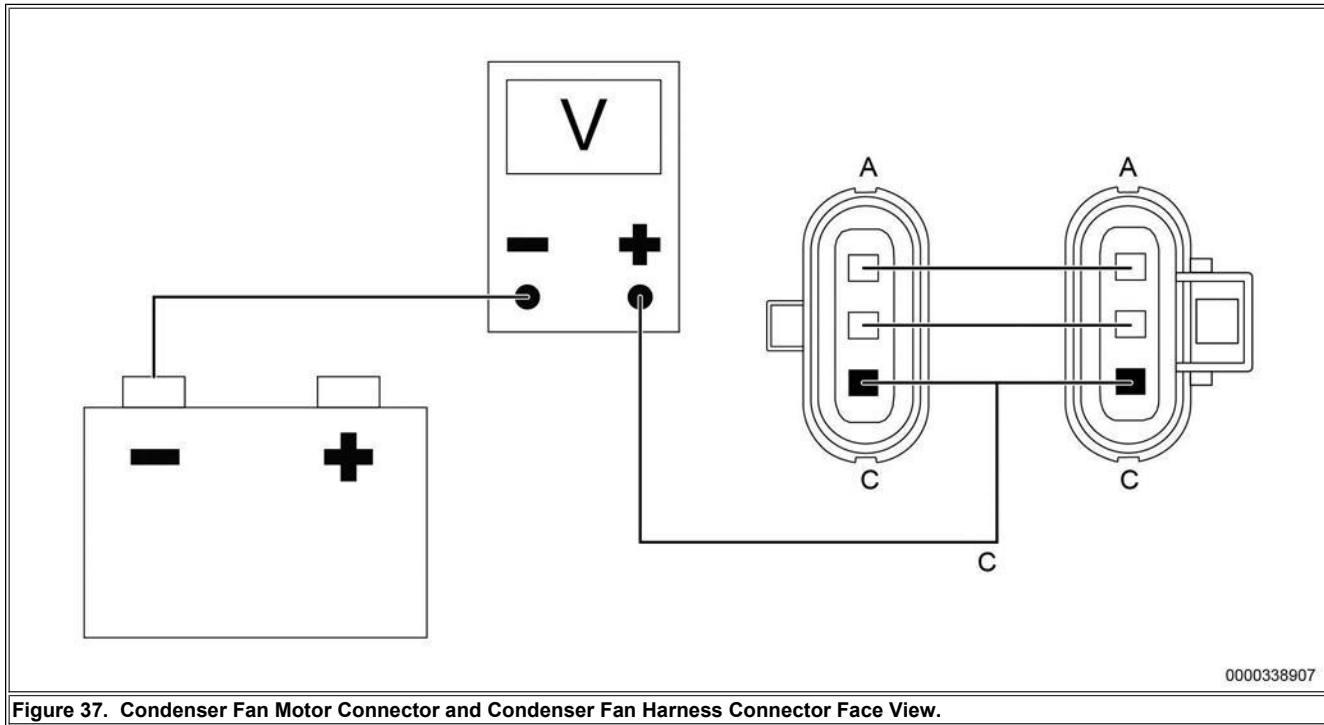
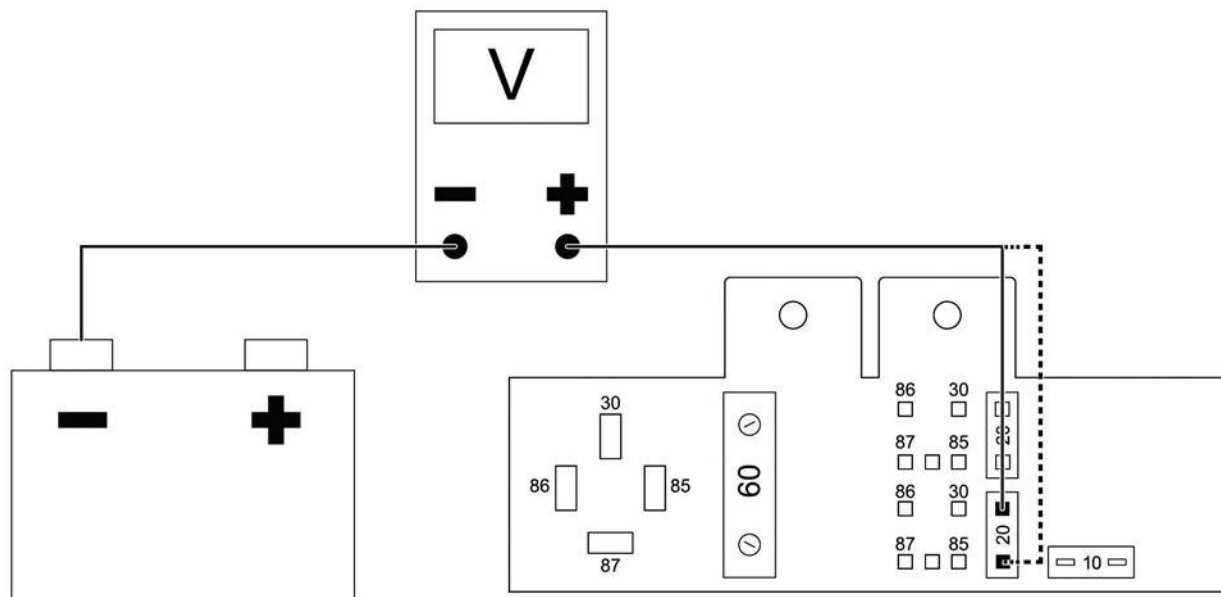

Figure 37. Condenser Fan Motor Connector and Condenser Fan Harness Connector Face View.

Step	Action	Decision
30	<p>CONDENSER FAN SPEED SIGNAL CHECK:</p> <ol style="list-style-type: none"> Disconnect condenser fan connector. Use Navistar Test Lead Kit (77066-NAV) to construct a breakout harness between condenser fan motor connector and No-Idle condenser fan connector. Turn ignition Key-Off and depress control panel COOL switch to start No-Idle A/C. Depress digital display temperature control to coldest setting. Depress digital display blower speed multiple times to highest setting. While condenser fan relay is enabled, use a DMM to measure voltage between test lead pin-C and a known good ground. Depress control panel COOL switch to turn No-Idle A/C off. Remove Navistar Test Lead Kit (77066-NAV) from condenser fan connector and No-Idle condenser fan connector. <p>Is voltage between on pin-C between 3.1V and 4.8V?</p>	<p>Yes. Replace fan assembly. Assemble unit to run and retest for operator concern.</p> <hr/> <p>No. Leave condenser fan connector disconnected and go to Step 32.</p>



0000329301

Figure 38. No-Idle Relay / Fuse Panel and Condenser Fan Fuse (F6).

Step	Action	Decision
31	CONDENSER FAN MOTOR PWR CIRCUIT CHECK:	Yes. Replace No-Idle harness. Assembly unit to run and retest for operator concern.
	a. Use a DMM to measure voltage on each side of Yellow 20A condenser fuse (F6) (Figure 38).	No. Neither side has B+ voltage: Check relay (R4), go to Step 42, fuse / relay panel connections, and 30A cube fuse.
	Does Yellow 20A condenser fan fuse (F6) have B+ on both sides?	No. Relay side of fuse (F6) has B+ and fuse is blown: Replace fuse (F6) and start No-Idle unit. If fuse (F6) blows, go to Step 45.

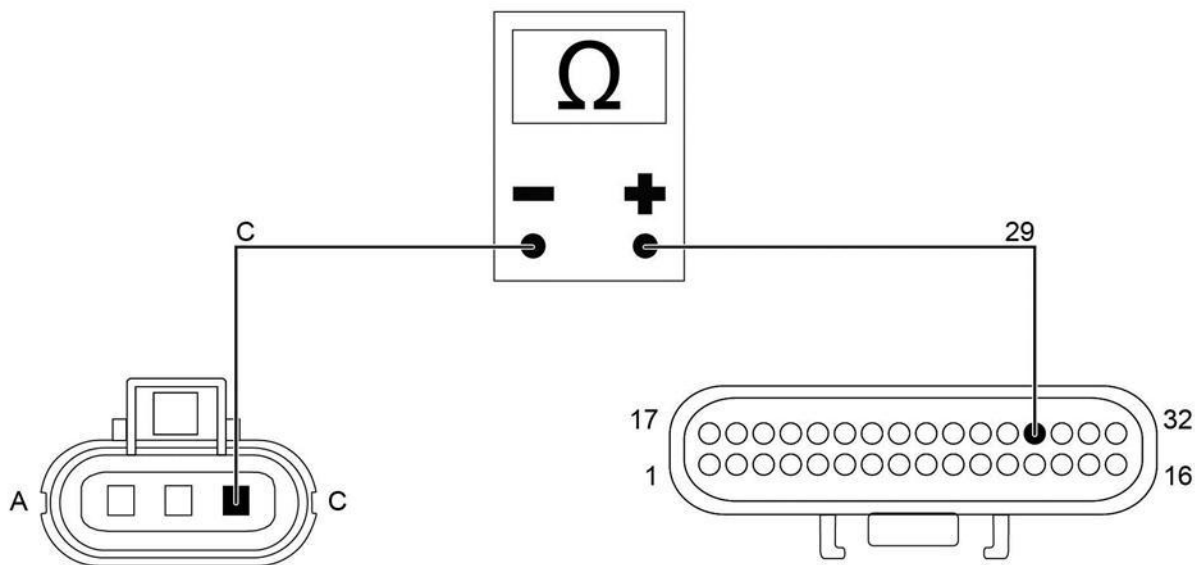

0000323481

Figure 39. 3-Way Condenser Fan Connector Face View and 32-Way System Controller Connector Face View.

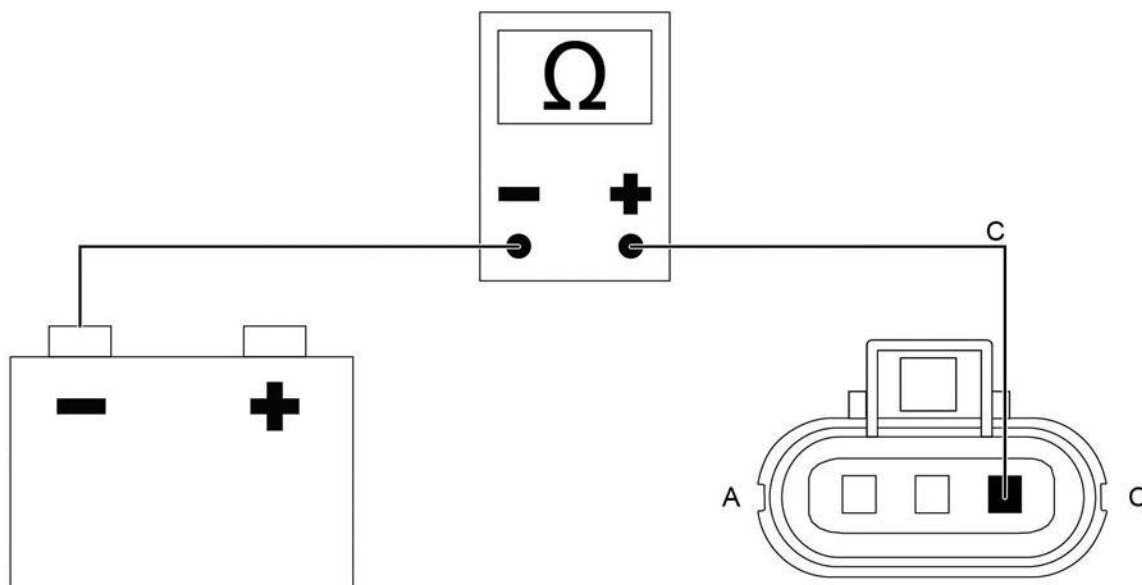

0000339881

Figure 40. 3-Way Condenser Fan Connector Face View.

CAUTION:

Do not attempt to connect an outside power source to the condenser fan motor. Internal electronic components are sensitive to arcing and reverse polarity; damage will occur.

Step	Action	Decision
32	<p>CONDENSER FAN SPEED SIGNAL CIRCUIT CHECK:</p> <p>a. Disconnect 32-way system controller connector.</p> <p>b. Use a DMM to check for continuity between pin-C and system controller connector pin-29 (Figure 39).</p>	<p>Yes. Replace system controller. Assemble unit to run and retest for operator concern.</p> <p>No. Replace No-Idle harness. Assemble unit to run and retest for operator concern.</p>

c. Use a DMM to check resistance between 3-way condenser fan connector pin-C and a known good ground (Figure 40).

Is Step 32.b measurement less than 5 Ohms and Step 32.c measurement greater than 1000 Ohms?

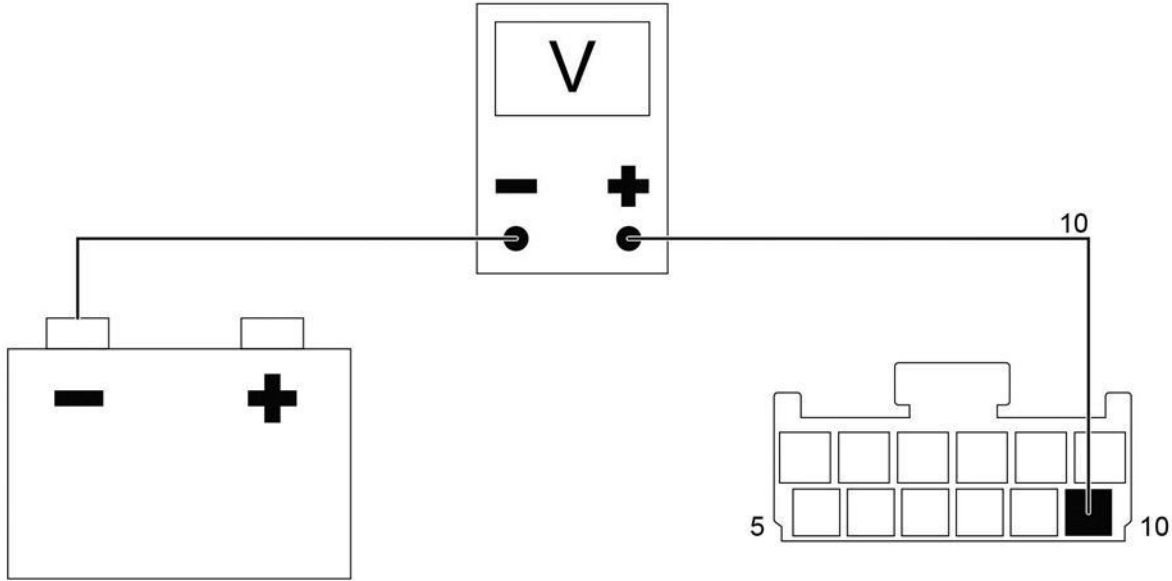

0000324481

Figure 41. 6-Way Blend Door Actuator Connector Back View.

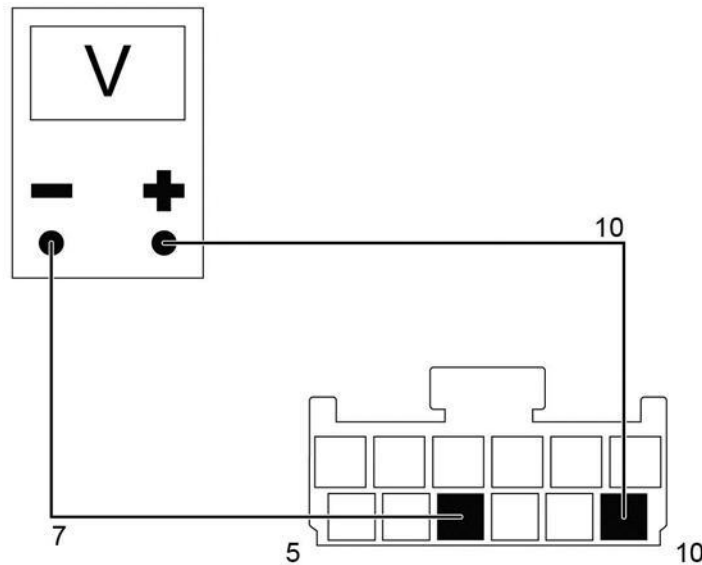

0000324501

Figure 42. 6-Way Blend Door Actuator Connector Back View.

Step	Action	Decision
33	<p>BLEND DOOR ACTUATOR PWR / GND CHECK:</p> <p>a. Verify blend door actuator is plugged in.</p>	<p>Yes. Go to Step 34.</p>

<p>b. Turn ignition Key-Off and depress control panel COOL switch to start No-Idle A/C. c. Use a DMM to back probe 6-way blend door actuator connector to measure voltage between pin-10 and a known good ground (Figure 41). d. Use a DMM to back probe 6-way blend door actuator connector to measure voltage between pin-10 and pin-7 (Figure 42).</p>	<p>No. Both Steps 33.c and 33.d have low or no voltage: Go to Step 37. No. Step 33.c has B+ but Step 33.d has low voltage: Go to Step 38.</p>
<p>Do both Steps 33.c and Step 33.d measure B+?</p>	

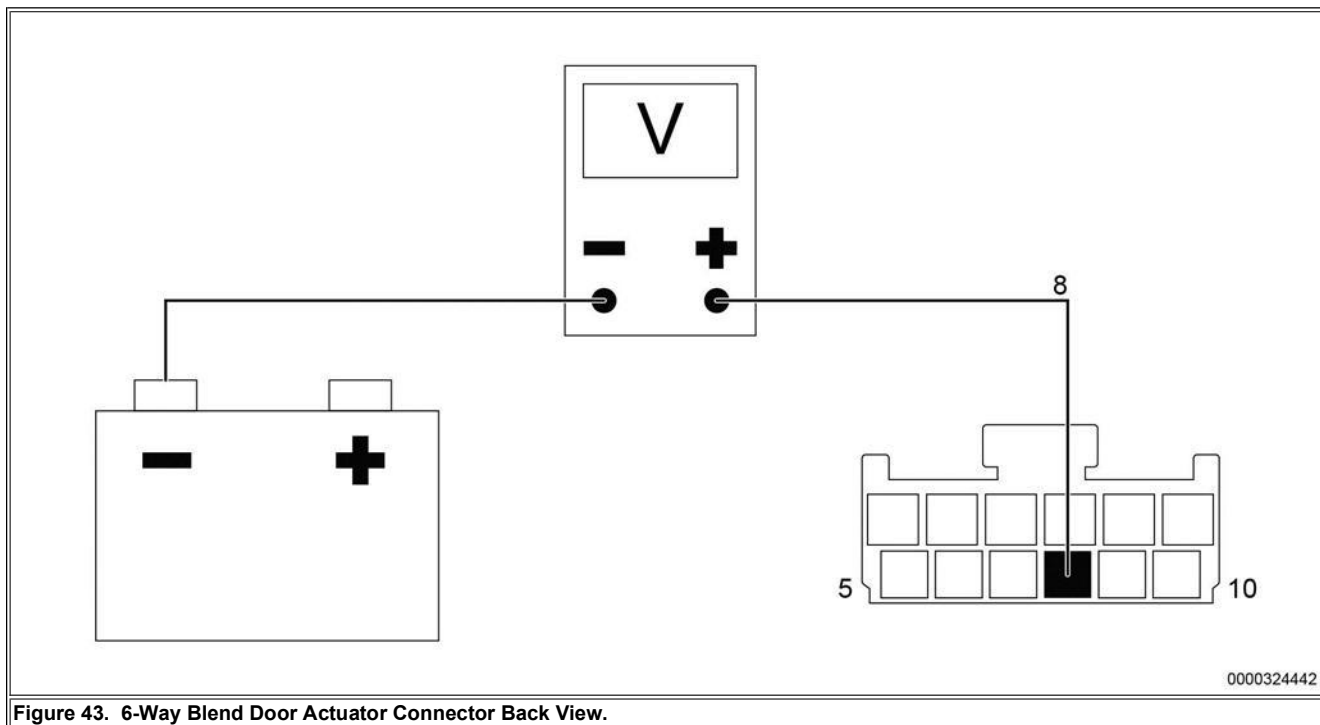
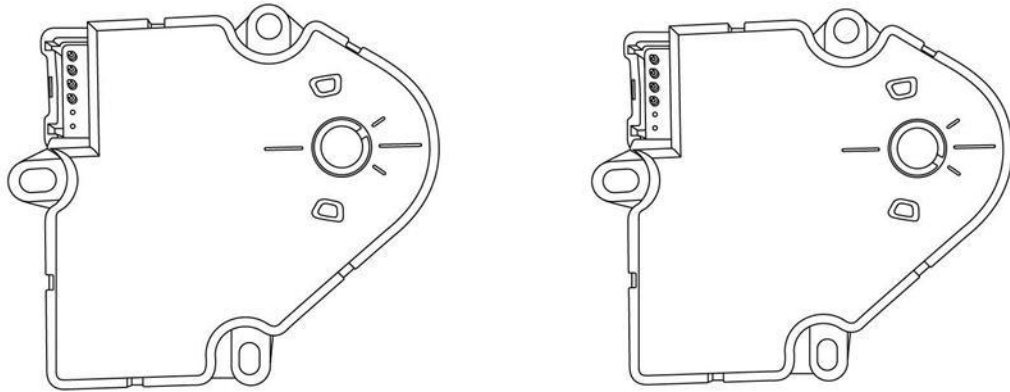

Figure 43. 6-Way Blend Door Actuator Connector Back View.

Step	Action	Decision
<p>34</p>	<p>BLENDED DOOR MOVE SIGNAL CHECK:</p> <p>a. Turn Key to Off position b. Use a DMM to back probe 6-way blend door actuator connector to measure voltage between pin-8 and a known good ground (Figure 43) as cool switch is depressed to start the no-idle A/C. c. Depress control panel COOL switch to stop No-Idle A/C. d. Use a DMM to back probe 6-way blend door actuator connector to measure voltage between pin-8 and a known good ground (Figure 43) as control panel HEAT switch is depressed to start No-Idle heater unit.</p> <p>Does Step 34.b measure close to 11V (after control panel COOL switch was depressed) and Step 34.d measure near 0V (after control panel HEAT switch was depressed)?</p>	<p>Yes. Go to Step 35. No. Voltage does not change or there is no voltage: Go to Step 36.</p>



0000329361

Figure 44. Blend Door Actuator (A/C) and Blend Door Actuator (Heat).

Step	Action	Decision
35	<p>BLEND DOOR MOVEMENT CHECK:</p> <ol style="list-style-type: none"> Remove blend door actuator from No-Idle housing. Verify No-Idle harness is connected to actuator. Turn ignition Key-Off and depress control panel COOL switch to start No-Idle A/C. Depress control panel COOL switch to stop No-Idle A/C. Depress control panel HEAT switch to start No-Idle heater. Note position of blend door actuator collar slot. Blend door actuator should rotate clockwise to HEAT position (Figure 44). Depress control panel HEAT switch to stop No-Idle heater. Depress control panel COOL switch momentarily to start No-Idle A/C. Note position of blend door actuator collar slot. Blend door actuator should be in COOL position (Figure 44). Depress control panel COOL switch momentarily to stop No-Idle A/C. Compare position of blend door actuator collar slot in Step 35.f and Step 35.i to Figure 44. <p>Is Step 35.f blend door actuator collar slot position correct for HEAT operation? Is Step 35.i blend door actuator collar slot position correct for A/C operation?</p>	<p>Yes. Move blend door actuator by hand to check for sticking or obstructions. Repair as needed. Assemble unit to run and retest for operator concern.</p> <p>No. Replace blend door actuator. Remove Red 10A controller fuse (F7) from No-Idle relay / fuse block. After 10 seconds, install Red 10A controller fuse (F7) to reset blend door actuator. Assemble unit to run and retest for operator concern.</p>

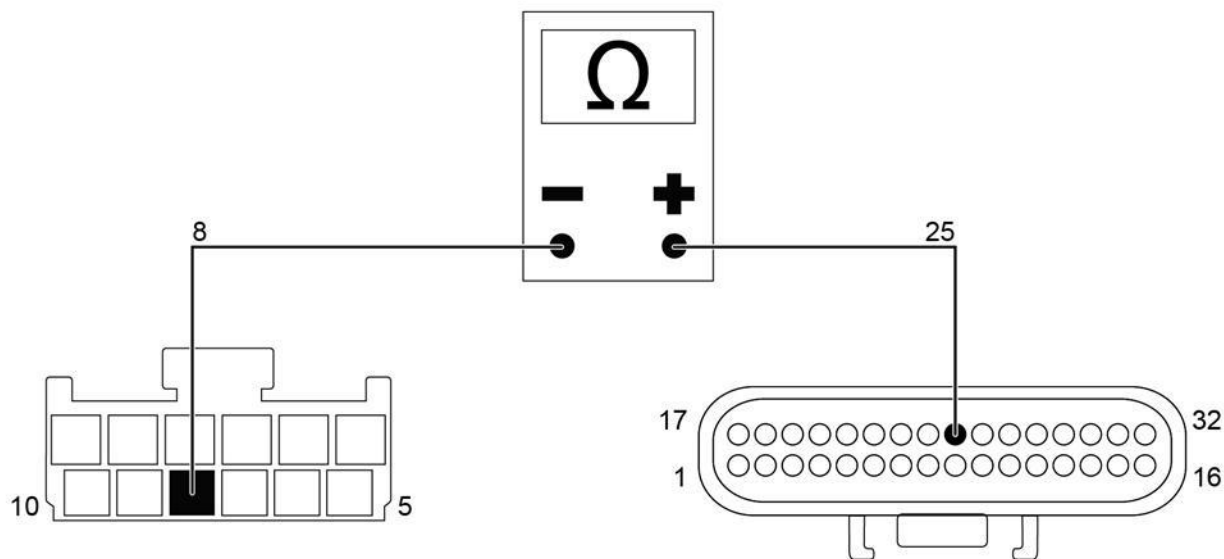

000036847

Figure 45. 32-Way System Controller Connector Face View and 6-Way Blend Door Actuator Connector Face View.

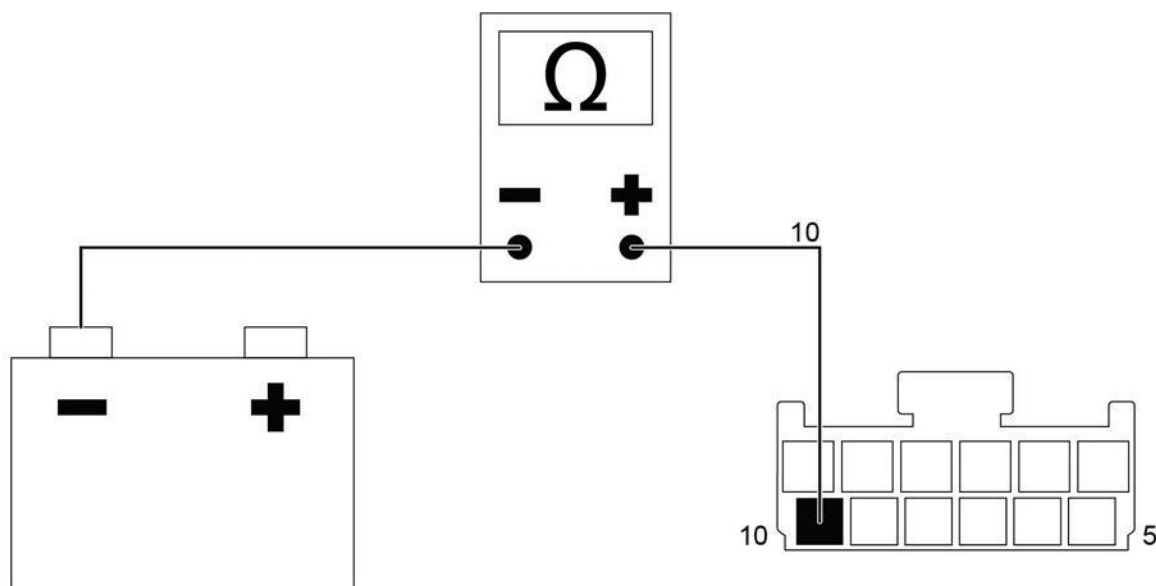

0000339921

Figure 46. 6-Way Blend Door Actuator Connector Face View.

Step	Action	Decision
36	<p>BLEND DOOR MOVE SIGNAL CIRCUIT CHECK:</p> <ul style="list-style-type: none"> a. Stop No-Idle unit. b. Disconnect 32-way system controller connector from system controller. c. Disconnect 6-way blend door actuator harness connector from blend door actuator. d. Use a DMM to measure continuity blend door actuator connector pin-8 and system controller connector pin-25 (Figure 45). e. Use a DMM to check resistance between 6-way blend door actuator harness pin-10 and a known good ground (Figure 46). 	<p>Yes. Replace system controller. Assemble unit to run and retest for operator concern.</p> <p>No. Replace No-Idle harness. Assemble unit to run and retest for operator concern.</p>

Is Step 36.d measurement less than 5 Ohms and Step 36.e measurement greater than 1000 Ohms?

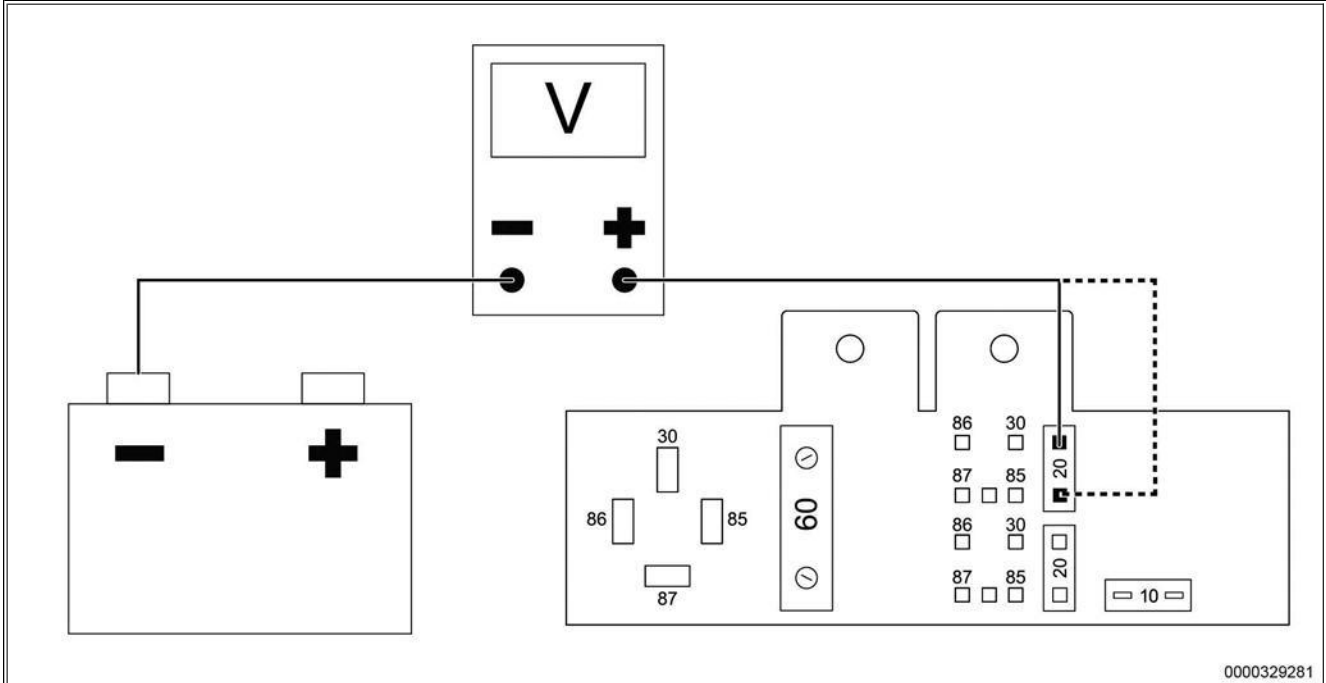

0000329281

Figure 47. No-Idle Relay / Fuse Panel, Blower Fuse (F5).

Step	Action	Decision
	BLEND DOOR ACTUATOR PWR CIRCUIT CHECK:	
	a. Use a DMM to measure voltage on both sides of Yellow 20A blower fuse (F5) (Figure 47).	Yes. Replace No-Idle harness. Assemble unit to run and retest for operator concern.
37	Does Yellow 20A blower fuse (F5) have B+ on both sides?	No. Neither side has B+: Go to Step 42 and test relay circuits.
		No. Yellow 20A blower fuse (F5) blows: Go to Step 43.

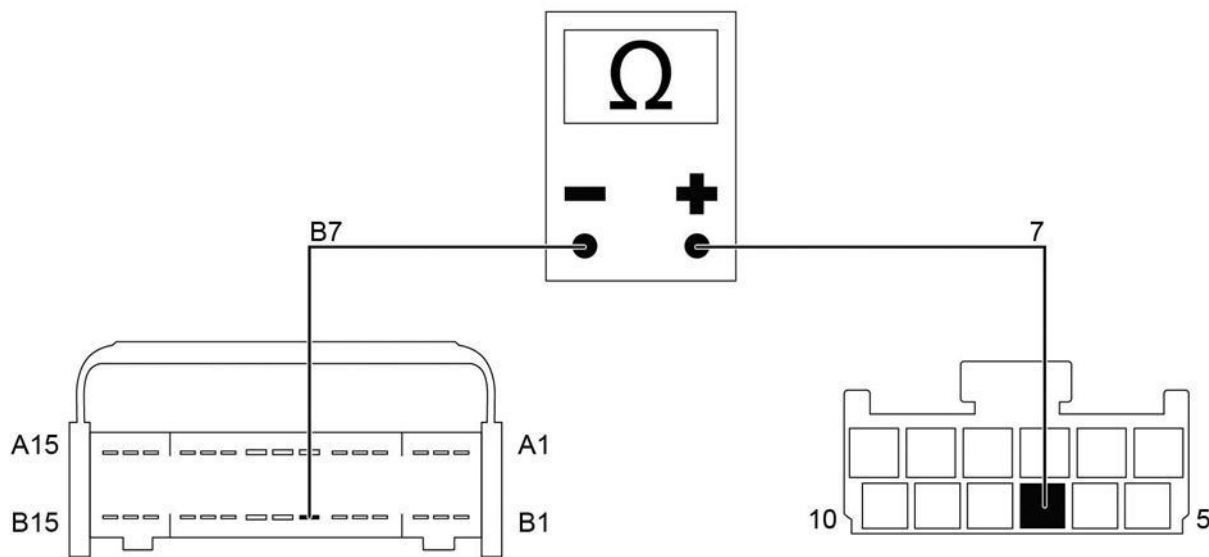

0000323441

Figure 48. 30-Way Chassis / No-Idle Harness Connector (5205) Face View and 6-Way Blend Door Actuator Harness Connector Face View.

Step	Action	Decision
38	<p>BLEND DOOR ACTUATOR GND CIRCUIT CHECK:</p> <p>a. Disconnect 30-way chassis / No-Idle harness connector (5205).</p> <p>b. Use a DMM to check continuity between 6-way blend door actuator harness connector pin-7 and 30-way chassis / No-Idle harness connector (5205) pin-B7 (Figure 48).</p>	<p>Yes. Locate and repair open or high resistance between 30-way chassis / No-Idle harness connector (5205) pin-B7 and battery ground. Assemble unit to run and retest for operator concern.</p>
	<p>Is continuity between pin-7 and pin-B7?</p>	<p>No. Replace No-Idle harness. Assemble unit to run and retest for operator concern.</p>

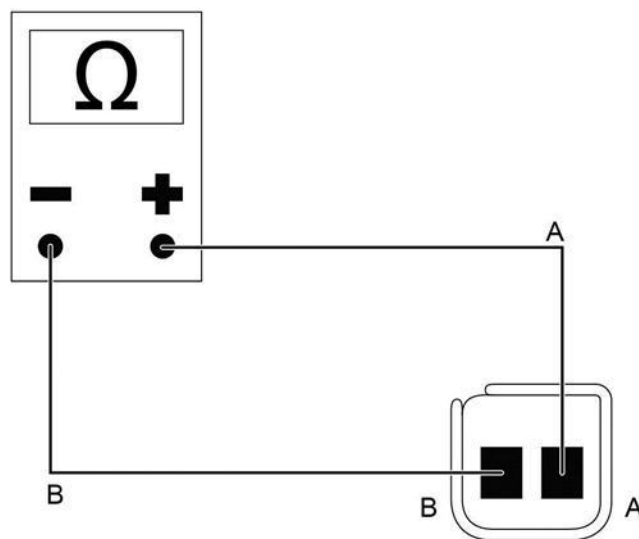

0000324861

Figure 49. 2-Way Inlet Temperature Sensor Pigtail Connector.

Step	Action	Decision
39	INLET TEMPERATURE SENSOR CIRCUIT CHECK: a. Disconnect inlet temperature sensor from No-Idle harness. b. Use a temperature probe from an A/C machine or a digital thermometer to measure ambient temperature in area of inlet temperature sensor. Record temperature. c. Use a DMM to measure resistance between 2-way inlet temperature sensor pigtail connector pin-A and pin-B (Figure 49). d. Locate temperature value (calculated in step 39b) on Discharge Sensor / Inlet Sensor Chart. See chart after Step 4. e. Compare measured resistance to Min - Max range on chart. Does measured resistance fall within Min - Max range on chart?	Yes. Replace No-Idle harness. Assemble unit to run and retest for operator concern. No. Replace inlet temperature sensor. Assemble unit to run and retest for operator concern.

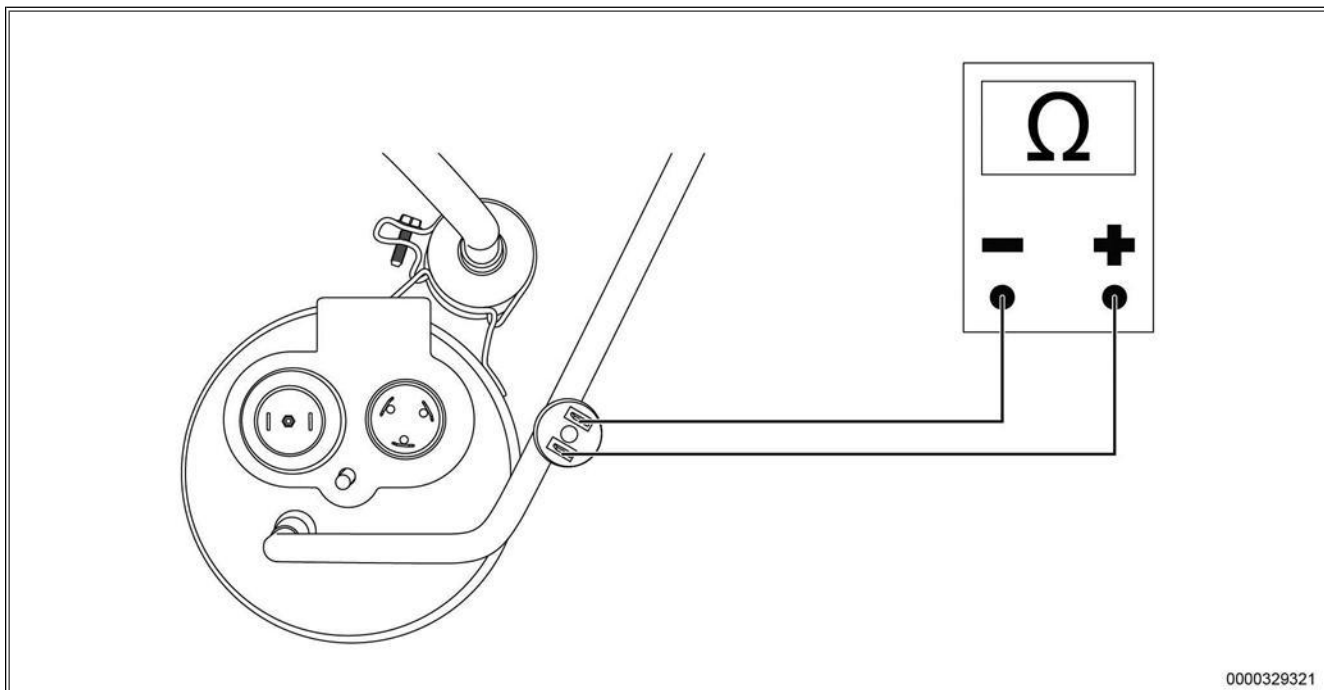

0000329321

Figure 50. Pressure Switch.

Step	Action	Decision
40	PRESSURE SWITCH CONTINUITY CHECK: a. Depress control panel COOL switch to stop No-Idle A/C b. Disconnect 32-way system controller connector from system controller. c. Remove compressor controller cover. d. Disconnect two wire terminals from pressure switch. <div style="border: 1px solid black; background-color: #00FF00; padding: 5px; width: fit-content;"> NOTE: </div> If sufficient air does not flow through condenser, refrigerant pressure may rise and open switch contacts. Allow unit to cool down and retest pressure switch. If switch is closed after cooling period, check for proper condenser fan operation and debris restricting air flow through condenser. e. Use a DMM to check continuity across pressure switch pins (Figure 50). Is continuity present across pressure switch pins?	Yes. Replace No-Idle harness. Assemble unit to run and retest for operator concern. No. Replace sealed refrigerant system. Assemble unit to run and retest for operator concern.

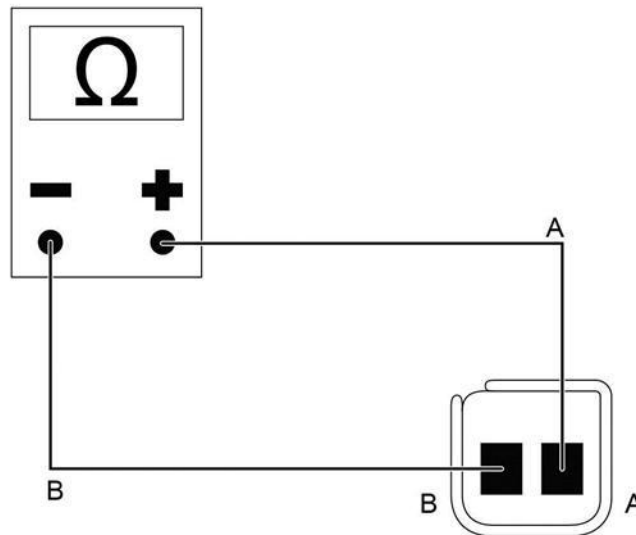

0000324861

Figure 51. 2-Way Discharge Temperature Sensor Pigtail Connector.

Step	Action	Decision
41	<p>DISCHARGE TEMPERATURE SENSOR CIRCUIT CHECK:</p> <p>A. Unplug the discharge temperature sensor from the No-idle harness. B. Use a temperature probe from an A/C machine or a digital thermometer to measure the ambient temperature in the area of the discharge temperature sensor. Record the temperature. C. Use a DMM to measure resistance between Pin-A and Pin-B of the sensor connector. D. Locate the temperature value on the Discharge Sensor/Inlet Sensor Chart. E. Compare the measured resistance to the min – max range on the chart.</p> <p>Does measured resistance fall within Min - Max range on chart?</p>	<p>Yes. Replace No-Idle harness. Assemble unit to run and retest for operator concern.</p> <p>No. Replace discharge temperature sensor. Assemble unit to run and retest for operator concern.</p>

Step	Action	Decision
42	<p>BLOWER and CONDENSER FAN RELAY TEST:</p> <p>a. Remove appropriate relay. b. Insert relay breakout harness ZTSE4674 or use Navistar Test Lead Kit (77066-NAV) between relay and relay panel. c. Turn ignition Key-Off. d. Depress control panel COOL switch momentarily to start No-Idle A/C. e. Raise blower speed to maximum setting and lower desired temperature to minimum setting.</p> <div style="border: 1px solid black; background-color: #90EE90; padding: 5px; margin: 10px 0;"> <p>NOTE:</p> </div> <p>Blower relay is enabled at start-up. Condenser relay is enabled at approximately same time as compressor relay.</p> <p>f. Listen for the low rumbling noise the compressor makes to verify operation or back probe the compressor controller and measure compressor speed input on Pin C16. Expect to see 5V until the compressor is commanded On. A voltage of 3.2-3.9 will tell the compressor to start. g. Verify relay pins match following voltages when relay is enabled by system controller:</p> <ul style="list-style-type: none"> • Pin-30 - B+ • Pin-85 - B+ • Pin-87 - B+ • Pin-86 - <2V 	<p>Yes. Relay is working correctly. Check circuit from pin-87 to load.</p> <p>No. Voltages are: • Pin-30 - B+ • Pin-85 - B+ • Pin-87 - 0V • Pin-86 - <2V</p> <p>Pin-30, pin-86, and pin-85 are correct. Pin-87 is 0V: Replace relay.</p> <p>No. Voltages are: • Pin-30 - 0V • Pin-85 - B+ • Pin-87 - 0V • Pin-86 - <2V</p> <p>Pin-30 has low or no voltage: Check 30-way chassis / No-Idle harness connector (5205) pin-A7 and pin-A8 and check 30A cube fuse.</p> <p>No. Voltages are: • Pin-30 - B+ • Pin-85 - 0V</p>

<p>Do voltages match?</p>	<ul style="list-style-type: none"> • Pin-87 - 0V • Pin-86 - 0V <p>Pin-85 has low or no voltage: Check Red 10A control fuse (F7), check 3-way chassis / No-Idle harness connector (5205) pin-A9.</p> <p>No. Voltages are:</p> <ul style="list-style-type: none"> • Pin-30 - B+ • Pin-85 - B+ • Pin-87 - 0V • Pin-86 - B+ <p>Pin-86 voltage is high: Check enable circuit for continuity to appropriate pin on system controller.</p>
---------------------------	--

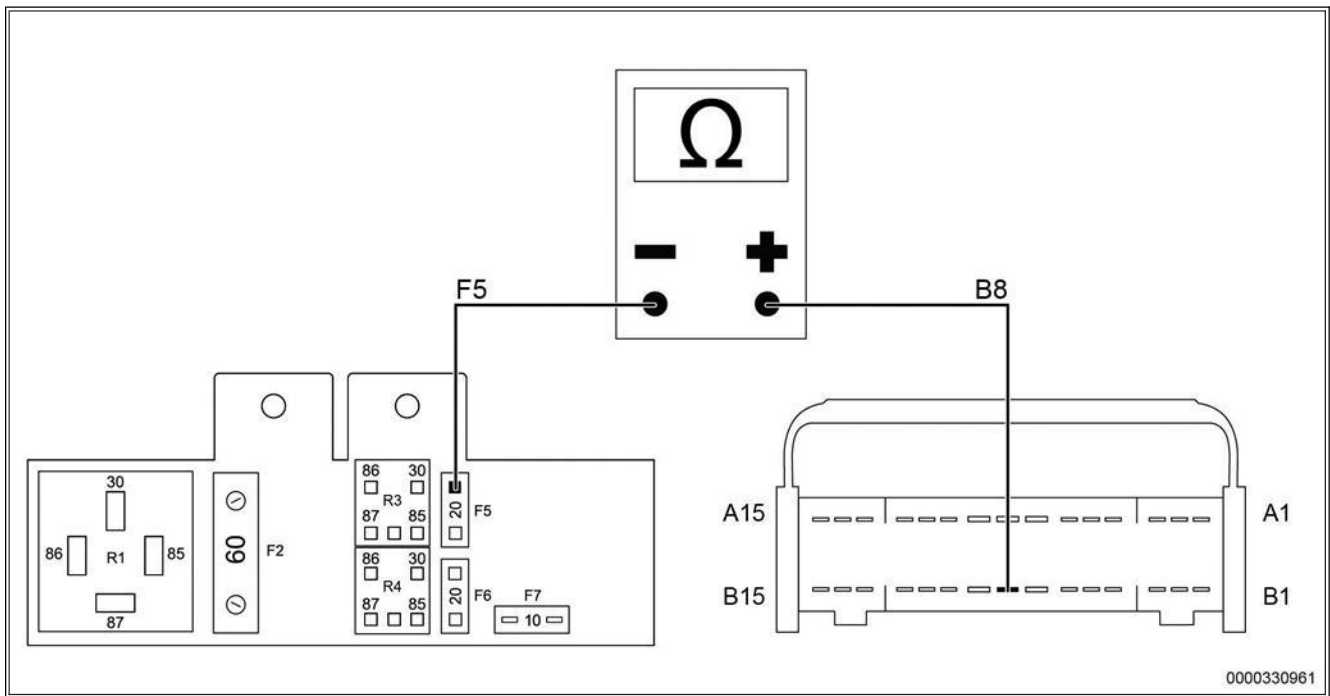

0000330961

Figure 52. Fuse Panel / Blower Fuse and 30-Way Chassis / No-Idle Harness Connector (5205).

Step	Action	Decision
43	<p>20A BLOWER FUSE TEST:</p> <p>a. Disconnect following connectors:</p> <ul style="list-style-type: none"> • LPM • Blend door actuator • Compressor controller • 30-way chassis / No Idle harness connector (5205) <p>b. Remove blower relay (R3).</p> <p>c. Insert a Yellow 20A fuse in (F5).</p> <p>d. Use a DMM to check continuity between blower fuse and 30-way chassis / No-Idle harness connector (5205) pin-B8 (Figure 52).</p> <p>Is there continuity between fuse (F5) and pin-B8?</p>	<p>Yes. Replace No-Idle harness. Assemble unit to run and retest for operator concern.</p> <hr/> <p>No. Go to Step 44.</p>

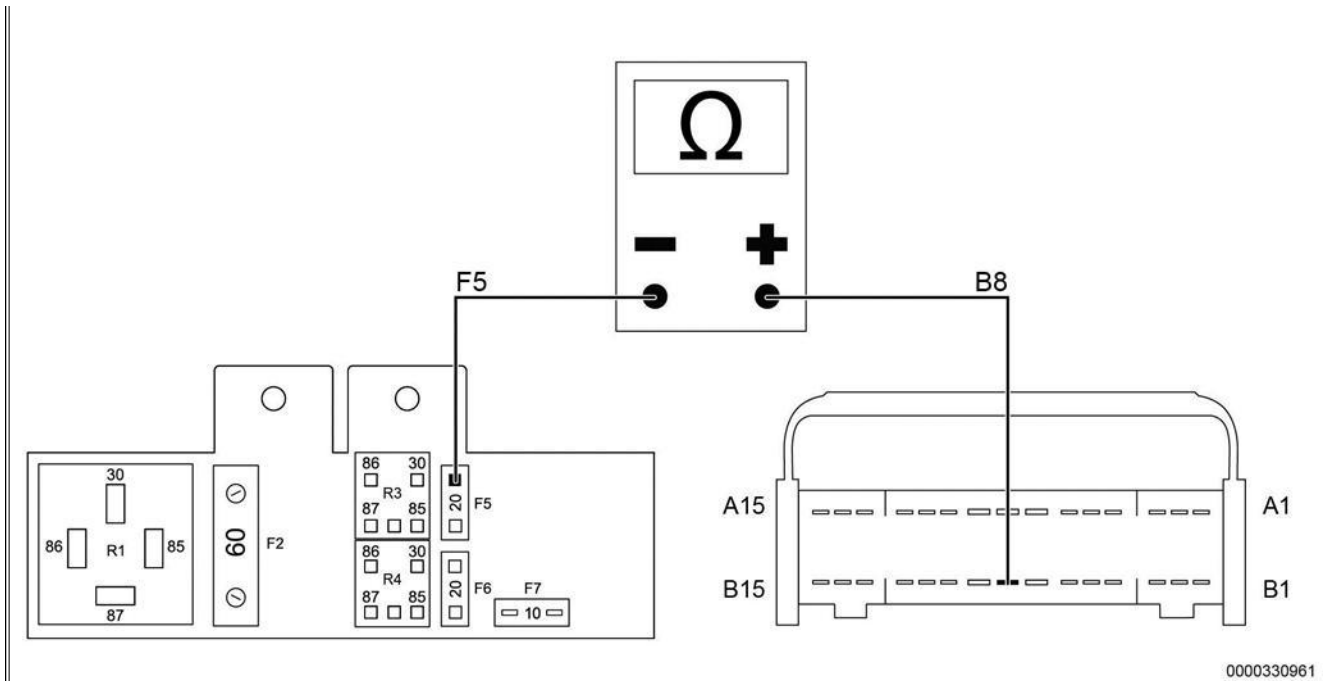

0000330961

Figure 53. Fuse Panel / Blower Fuse and 30-Way Chassis / No-Idle Harness Connector (5205).

Step	Action	Decision
44	20 AMP Blower Fuse Circuit Test	
	a. Connect 30-way chassis / No-Idle connector (5205).	30-way chassis / No-Idle harness connector (5205): Check digital display harness for short to ground.
	b. Use a DMM to check continuity between blower fuse (F5) and 30-way chassis / No-Idle harness connector (5205) pin-B8 (Figure 53).	LPM: Replace LPM. Assemble unit to run and retest for operator concern.
	c. Connect No-Idle harness to LPM.	Blend door actuator: Replace blend door actuator. Assemble unit to run and retest for operator concern.
	d. Use a DMM to check continuity between blower fuse (F5) and 30-way chassis / No-Idle harness connector (5205) pin-B8 (Figure 53).	
	e. Connect No-Idle harness to blend door actuator.	
	f. Use a DMM to check continuity between blower fuse (F5) and 30-way chassis / No-Idle harness connector (5205) pin-B8 (Figure 53).	
	g. Connect No-Idle harness to compressor controller.	
	h. Use a DMM to check continuity between blower fuse (F5) and 30-way chassis / No-Idle harness connector (5205) pin-B8 (Figure 53).	
	Which component caused continuity between blower fuse (F5) and 30-way chassis / No-Idle connector (5205) pin-B8?	Compressor controller: Replace compressor controller. Assemble unit to run and retest for operator concern.

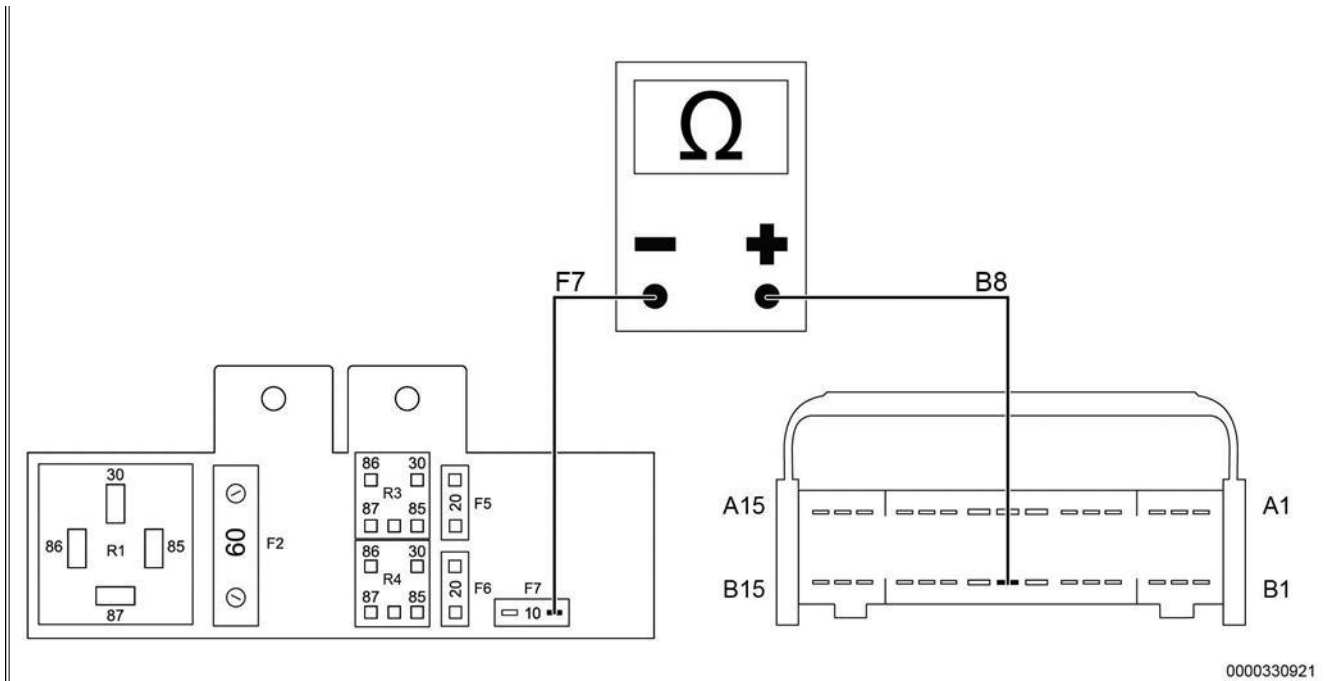
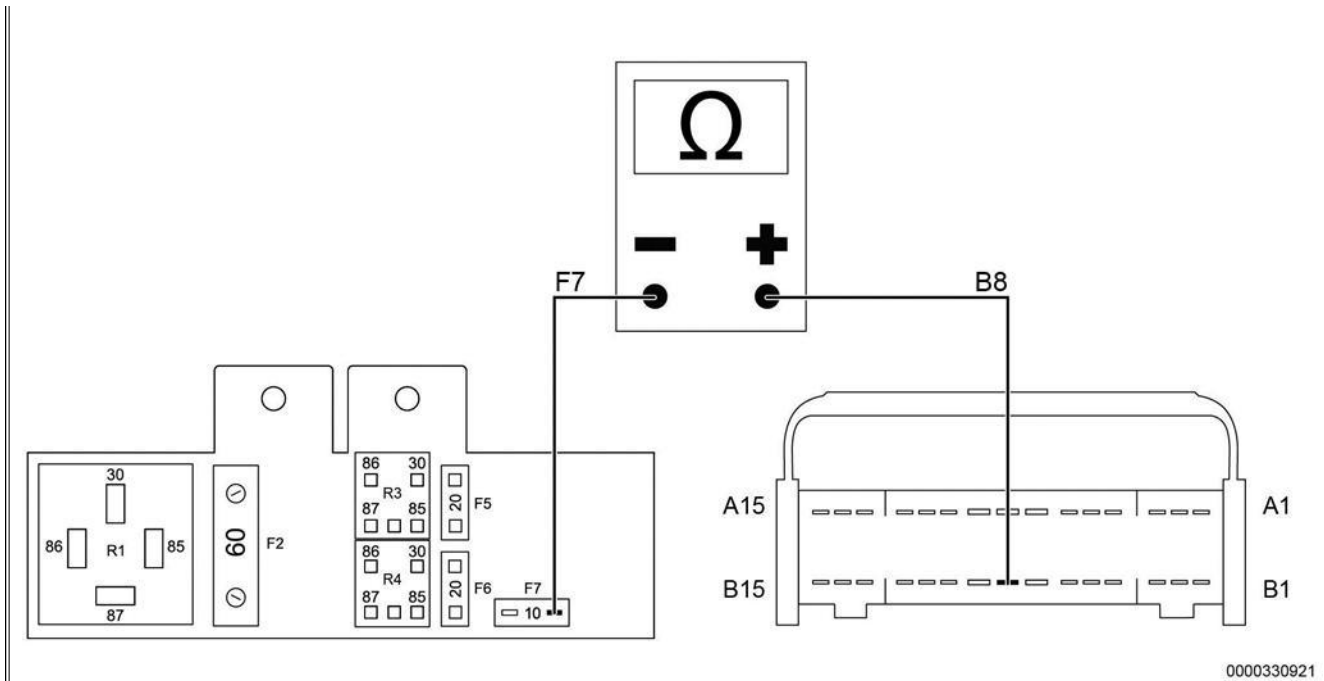

Figure 54. Fuse Panel / Load Side of 10A Control Fuse and 30-Way Chassis / No-Idle Harness Connector (5205).

Step	Action	Decision
45	<p>10A CONTROL FUSE TEST:</p> <p>a. Disconnect following connectors:</p> <ul style="list-style-type: none"> • System controller • 30-way chassis / No Idle harness connector (5205) <p>b. Remove blower relay (R3) and condenser relay (R4).</p> <p>c. Remove Red 10A control fuse (F7).</p> <p>d. Use a DMM to check continuity between load side of Red 10A control fuse (F7) and 30-way chassis / No-Idle harness connector (5205) pin-B8 (Figure 54).</p> <p>Is there continuity between F7 and pin-B8?</p>	<p>Yes. Replace No-Idle harness. Assemble unit to run and retest for operator concern.</p>
	<p>No. Go to Step 46.</p>	



0000330921

Figure 55. Fuse Panel / Load Side of 10A Control Fuse and 30-Way Chassis / No-Idle Harness Connector (5205).

Step	Action	Decision
46	<p>10A CONTROL FUSE CIRCUIT CHECK:</p> <p>a. Connect 30-way chassis / No-Idle connector (5205).</p> <p>b. Use a DMM to check continuity between 10A control fuse (F7) and 30-way chassis / No-Idle harness connector (5205) pin-B8 (Figure 55).</p> <p>c. Install blower relay (R3) into fuse / relay panel.</p> <p>d. Use a DMM to check continuity between 10A control fuse (F7) and 30-way chassis / No-Idle harness connector (5205) pin-B8 (Figure 55).</p> <p>e. Install condenser relay (R4) into fuse / relay panel.</p> <p>f. Use a DMM to check continuity between 10A control fuse (F7) and 30-way chassis / No-Idle harness connector (5205) pin-B8 (Figure 55).</p> <p>g. Connect No-Idle harness to system controller.</p> <p>h. Use a DMM to check continuity between 10A control fuse (F7) and 30-way chassis / No-Idle harness connector (5205) pin-B8 (Figure 55).</p>	<p>30-way chassis / No-Idle harness connector (5205): Check control panel VBAT circuit for short to ground.</p>
		Blower relay: Replace No-Idle harness.
		Condenser relay: Replace No-Idle harness.
		System controller: Replace system controller.
	Which component caused continuity to ground?	

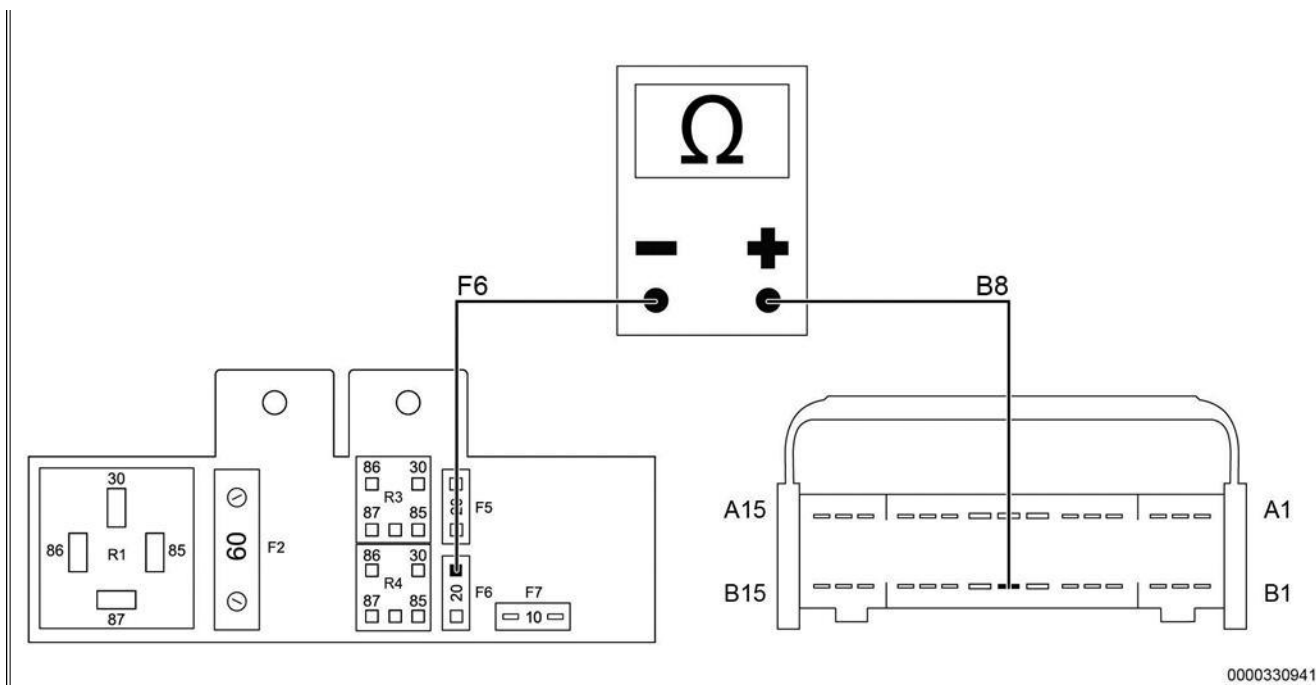

0000330941

Figure 56. Fuse Panel / Load Side Fuse (F6) Removed and No-Idle Side of 30-Way Chassis / No-Idle Harness Connector (5205).

Step	Action	Decision
47	<p>20A CONDENSER FUSE (F6) TEST:</p> <ol style="list-style-type: none"> Remove condenser fan grille to allow access to 3-way condenser fan connector. Disconnect 3-way condenser fan connector from condenser fan pigtail connector. Disconnect 30-way chassis / No-Idle harness connector (5205), Insert a new Yellow 20A condenser fuse (F6) into fuse / relay panel. Remove condenser relay (R4) from fuse / relay panel. Use a DMM to check continuity between load side of Yellow 20A condenser fuse (F6) and 30-way chassis / No-Idle harness connector (5205) pin-B8 (Figure 56). <p>Is continuity present between Yellow 20A condenser fuse (F6) and 30-way chassis / No-Idle harness connector (5205) pin-B8?</p>	<p>Yes. Replace No-Idle harness. Assemble unit to run and retest for operator concern.</p> <hr/> <p>No. Replace condenser fan. Reassemble unit to run and retest for operator concern.</p>

REPAIR STEP(S)

Not Applicable

REMOVAL PROCEDURE:

Not Applicable

INSTALLATION PROCEDURE:

Not Applicable

WARRANTY INFORMATION

Warranty Claim Coding:

Group:	19030 - Auxiliary No-Idle HVAC
---------------	--------------------------------

Noun: 638 - Electric HVAC Module

- Link to the Coding Manual: [Click Here](#)

Standard Repair Time(s) - ProStar:

Step	Description	Chassis	Engine	SRT	Hours
1 - 8	Thermal Limit Switch	ProStar	N/A	R20-1008A	0.2 Hr
1 - 15	Compressor Controller High Amp Pwr/Gnd Check and Output Check	ProStar	N/A	R20-1008A-20	0.5 Hr
1 - 12, 16	Compressor Speed Signal Check	ProStar	N/A	R20-1008A-21	0.4 Hr
1 - 13, 17, 43 - 44	Compressor Controller Low Amp Pwr Circuit Check	ProStar	N/A	R20-1008A-22	0.5 Hr
1 - 2, 18 - 19, 44	System Controller Pwr/Gnd Check	ProStar	N/A	R20-1008A-23	0.2 Hr
1 - 3, 20 - 22	Cool Switch Operation Check	ProStar	N/A	R20-1008A-24	0.2 Hr
1 - 7, 23 - 25, 43 - 44	LPM Pwr/Gnd Circuit Check	ProStar	N/A	R20-1008A-25	0.3 Hr
1 - 7, 23, 26 - 28	Evaporator Blower Speed Signal Check	ProStar	N/A	R20-1008A-26	0.3 Hr
1 - 10, 29 - 32, 42, 45 - 47	Condenser Fan Speed Signal Circuit Check	ProStar	N/A	R20-1008A-27	0.6 Hr
1 - 9, 33 - 38, 42 - 44	Blend Door Actuation / Circuit Check	ProStar	N/A	R20-1008A-28	0.4 Hr
1 - 5, 39	Inlet Temperature Sensor Circuit Check	ProStar	N/A	R20-1008A-29	0.2 Hr
1 - 6, 40	Pressure Switch Continuity Check	ProStar	N/A	R20-1008A-30	0.1 Hr
1 - 4, 41	Discharge Temperature Sensor Circuit Check	ProStar	N/A	R20-1008A-31	0.2 Hr

Standard Repair Time(s) - LoneStar:

Step	Description	Chassis	Engine	SRT	Hours
1 - 8	Thermal Limit Switch	LoneStar	N/A	S20-1008A	0.2 Hr
1 - 15	Compressor Controller High Amp Pwr/Gnd Check and Output Check	LoneStar	N/A	S20-1008A-20	0.5 Hr
1 - 12, 16	Compressor Speed Signal Check	LoneStar	N/A	S20-1008A-21	0.4 Hr
1 - 13, 17, 43 - 44	Compressor Controller Low Amp Pwr Circuit Check	LoneStar	N/A	S20-1008A-22	0.5 Hr
1 - 2, 18 - 19, 44	System Controller Pwr/Gnd Check	LoneStar	N/A	S20-1008A-23	0.2 Hr
1 - 3, 20 - 22	Cool Switch Operation Check	LoneStar	N/A	S20-1008A-24	0.2 Hr
1 - 7, 23 - 25, 43 - 44	LPM Pwr/Gnd Circuit Check	LoneStar	N/A	S20-1008A-25	0.3 Hr
1 - 7, 23, 26 - 28	Evaporator Blower Speed Signal Check	LoneStar	N/A	S20-1008A-26	0.3 Hr
1 - 10, 29 - 32, 42, 45 - 47	Condenser Fan Speed Signal Circuit Check	LoneStar	N/A	S20-1008A-27	0.6 Hr
1 - 9, 33 - 38, 42 - 44	Blend Door Actuation / Circuit Check	LoneStar	N/A	S20-1008A-28	0.4 Hr
1 - 5, 39	Inlet Temperature Sensor Circuit Check	LoneStar	N/A	S20-1008A-29	0.2 Hr
1 - 6, 40	Pressure Switch Continuity Check	LoneStar	N/A	S20-1008A-30	0.1 Hr
1 - 4, 41	Discharge Temperature Sensor Circuit Check	LoneStar	N/A	S20-1008A-31	0.2 Hr

- Link to the Standard Repair Time Manual: [Click Here](#)

Claim SRT Example:
Not Applicable

Claim Comment Suggestion:
Not Applicable

Special Requirement(s):
Not Applicable

OTHER RESOURCES

Circuit Diagrams By Unit Build Date		
MaxxPower No-Idle System Circuit Diagram (PDF)	Units Prior to November 11, 2013	Click Here
MaxxPower No-Idle System Circuit Diagram (PDF)	Units from November 11, 2013 to June 23, 2014	Click Here
MaxxPower No-Idle System Circuit Diagram (PDF)	Units from June 24, 2014 through Current	Click Here

[Master Service Information Site](#)

 Hide Details

Feedback Information

Viewed: 1196
 Helpful: 1
 Not Helpful: 1

No Feedback Found