



FIELD SERVICE CAMPAIGN – 15110

October 1, 2015

Subject:

Engine Fan Shroud Ring

Models Involved:

WorkStar®

Defect Description:

The engine fan shroud seal ring may be damaged by the fan during vehicle articulation.

Eligibility:

This procedure applies ONLY to vehicles marked in the International® Service PortalSM with FSC 15110. Also complete any other open campaigns listed on the Service Portal at this time.

Tools Required:

Description	Tool Number
9/64 in Drill Bit	N/A

Table 1 Tools Information

Parts Required:

NOTE: WinZip software must be installed on the computer being utilized with the Fleet Information Request Tool in order to open larger compressed files sent via email.

NOTE: The scope of this campaign is narrow in that it only affects 523 vehicles. DO NOT preorder campaign parts for inventory, and only order campaign parts when a customer repair request is confirmed. This will allow campaign parts to be available for each dealer when a customer requests the repair.

NOTE: There are two different repair methods depending on the part specified by Navistar for the particular vehicle being repaired.

International
Fleet Information Request Tool

Home Publications Service Reference Write Up Dealer Warranty Support Chassis / VIN Number View

File : Browse... Download Sample File Need help

Email Address :

Fleet Info Request (2500 Row Limit)

Campaign Parts Recall 14516

Submit Reset

Copyright 2015 Navistar, Inc.

0000367261

Figure 1. Fleet Information Request Tool.

Fleet Information Request Tool (Figure 1) via VIN submission:

- a. **Navigate to International[®] Service PortalSM, select WARRANTY, then FLEET INFORMATION REQUEST TOOL (https://evaluate.internationaldelivers.com/service/service_info/FleetInfoRequestTool.aspx).**
- b. **Upload a complete VIN list (sample format provided on Request Tool web site).**
- c. **Click on CAMPAIGN PARTS and select the associated recall.**
- d. **Click on SUBMIT.**
- e. **An e-mail will be sent to the requestor depicting appropriate kit P/N associated with the VIN list submitted.**

Work Instructions

WARNING! To prevent property damage, personal injury, and / or death, park vehicle on hard flat surface, turn the engine off, set the parking brake, and install wheel chocks to prevent the vehicle from moving in both directions.

WARNING! To prevent personal injury and / or death, always wear safe eye protection when performing vehicle maintenance.

WARNING! To prevent property damage, personal injury, and / or death, keep flames or sparks away from vehicle and do not smoke while servicing the vehicle's batteries. Batteries expel explosive gases.

1. Bring vehicle into shop and park on flat surface.
2. Shift transmission to Park or Neutral and set parking brake.
3. Install wheel chocks.
4. Unlatch and open hood.
5. Remove driver and passenger side splash panels to gain access. Refer to Service Manual section, [Splash Panel \(Navistar 11 and 13 Engines\) \(Enhanced Vision\) – Removal](#).

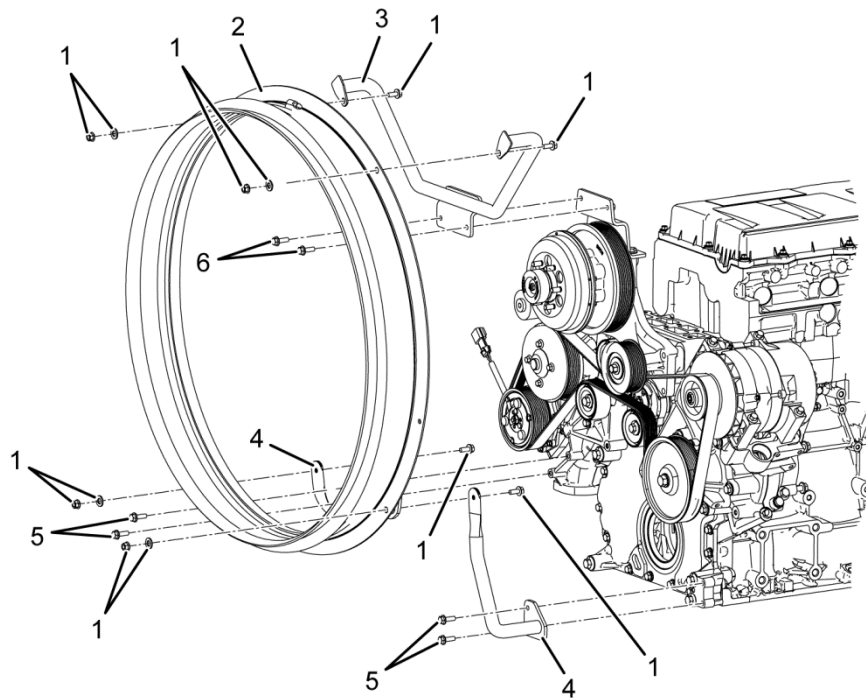

0000388864

Figure 2. Fan Ring.

1. Fastener assembly (bolt, washer, and nut) (4 assemblies total)
2. Fan ring
3. Upper fan ring bracket
4. Lower fan ring bracket (2)
5. Bolt (4)
6. Bolt (2)

6. Remove four bolt assemblies (Figure 2, Item 1) securing fan ring (Figure 2, Item 2) to upper fan ring bracket (Figure 2, Item 3) and lower fan ring brackets (Figure 2, Item 4).
7. Remove mounting bolts (Figure 2, Item 6) securing upper fan ring bracket to mounting. Remove upper fan ring bracket.
8. Remove mounting bolts (Figure 2, Item 5) securing both lower fan ring brackets.
9. Remove both lower fan ring brackets (Figure 2, Item 4), and position fan ring rearward.

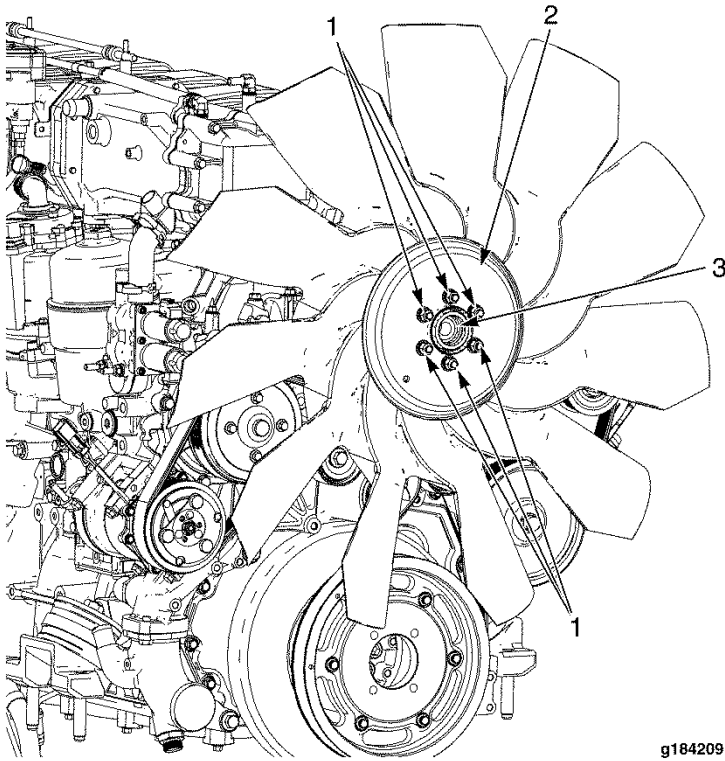

g184209

Figure 3. Radiator Fan.

1. Nut and washer assembly (6)
2. Radiator fan
3. Fan drive

NOTE: If necessary, save fasteners for reuse.

10. Remove six nut and washer assemblies (Figure 3, Item 1) securing radiator fan (Figure 3, Item 2) to fan drive (Figure 3, Item 3).

11. Remove radiator fan and fan ring.

NOTE: There are two different repair methods depending on the part specified by Navistar for the particular vehicle being repaired.

12. There is one of two repair methods for the vehicle being repaired:

- a) If the vehicle ONLY requires installation of a fir tree push mount cable tie, position previously removed radiator fan onto fan drive. Install six nut and washer assemblies. Using torque wrench, tighten nuts to 26 lb-ft (35 N·m). Proceed to Step 13.
- b) If the vehicle requires a new radiator fan and installation of a fir tree push mount cable tie, position new radiator fan onto fan drive. Install six nut and washer assemblies. Using torque wrench, tighten nuts to 26 lb-ft (35 N·m). Proceed to Step 13.

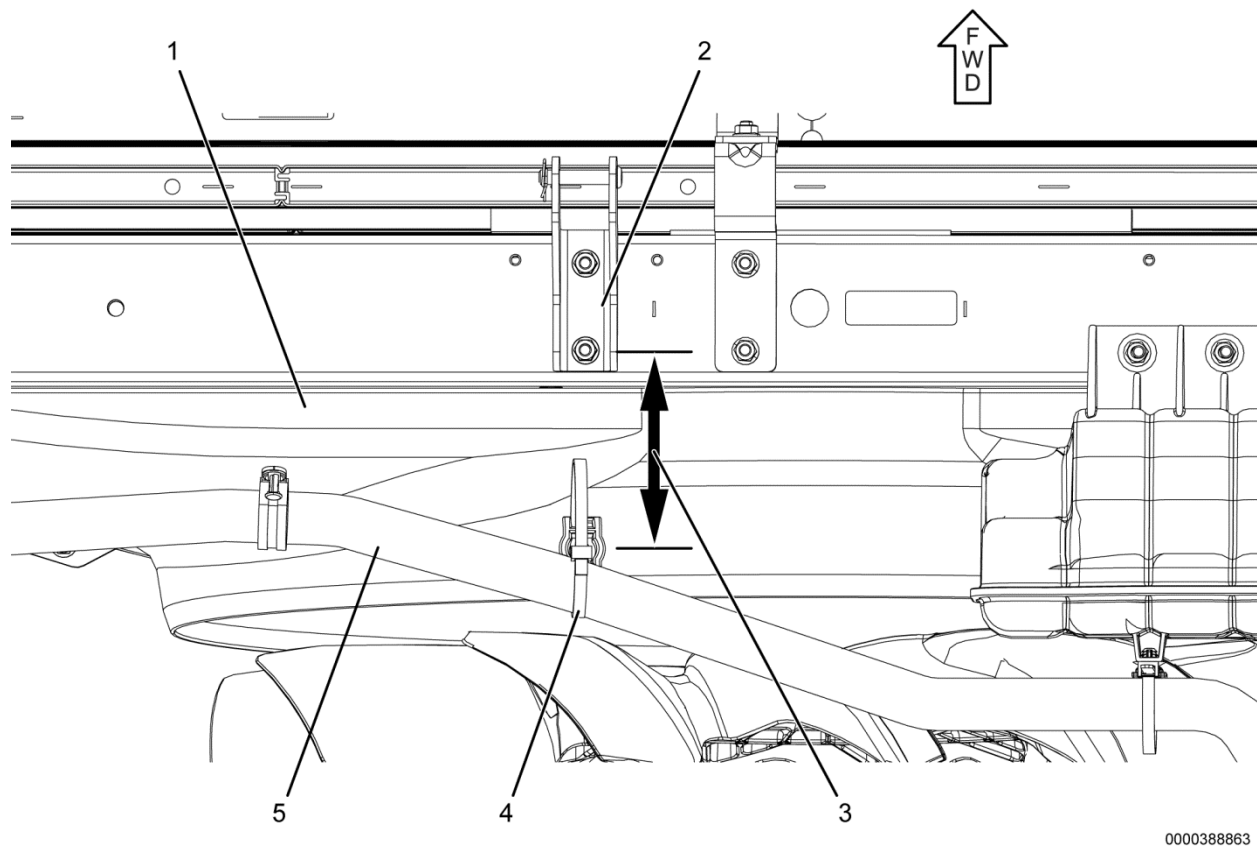

0000388863

Figure 4. Radiator Fan Shroud.

1. Upper fan shroud
2. Hood tilt assist mounting bracket
3. Dimension measurement - 5 in (125 mm)
4. Fir tree push mount cable tie
5. Low temperature radiator supply hose

13. Using a power drill, drill hole in upper fan shroud (Figure 4, Item 1):

- a) Locate hood tilt assist bracket (Figure 4, Item 2).
- b) Measure 5 in (125 mm) (Figure 4, Item 3) directly rearward from centerpoint of rear bolt and mark area in upper fan shroud.
- c) Using 1/8 in (3 mm) drill bit, drill pilot hole in area previously marked.
- d) Using 11/32 in (9 mm) drill bit, drill primary hole in fan shroud.

14. Insert fir tree push mount cable tie (Figure 4, Item 4) into recently drilled hole in fan shroud.

15. Secure low temperature radiator supply hose (Figure 4, Item 5) with cable tie strap of fir tree push mount cable tie, and tighten cable tie strap. Cut off extra cable tie strap end and discard.
16. Install driver and passenger side splash panels. Refer to service manual section, [Splash Panel \(Navistar 11 and 13 Engines\) \(Enhanced Vision\) – Installation](#).
17. Close and latch hood.
18. Remove wheel chocks.

LABOR INFORMATION

Operation number must appear on all claims.

Table 2 Labor Information

Operation Number	Description	Time
A40-15110-1	Remove Fan Shroud Ring and Install Fir Tree Push Mount Cable Tie	1.4 hrs

WARRANTY CLAIMS

Warranty claim expense is to be charged to Warranty. Claims are to be submitted in the normal manner, making reference to Field Service Campaign 15110.

It is important that the coding be completed properly to assist in processing the warranty claim. Complete instructions will be found in the Warranty Policy Manual, Section 7.1.8.

As with all claim submissions, items acquired locally must be submitted in the “Other Charges” tab. The cost of any bulk items (such as a bag of cable tie straps, roll of wire, barrel of oil, or tube of silicone) should be prorated for the cost of the individual pieces / amount used during each repair.

To make sure this important improvement is made in a timely manner, all claims for 15110 activity must be submitted by 01 October 2016 or within the normal warranty period for the component, if after 01 October 2016.

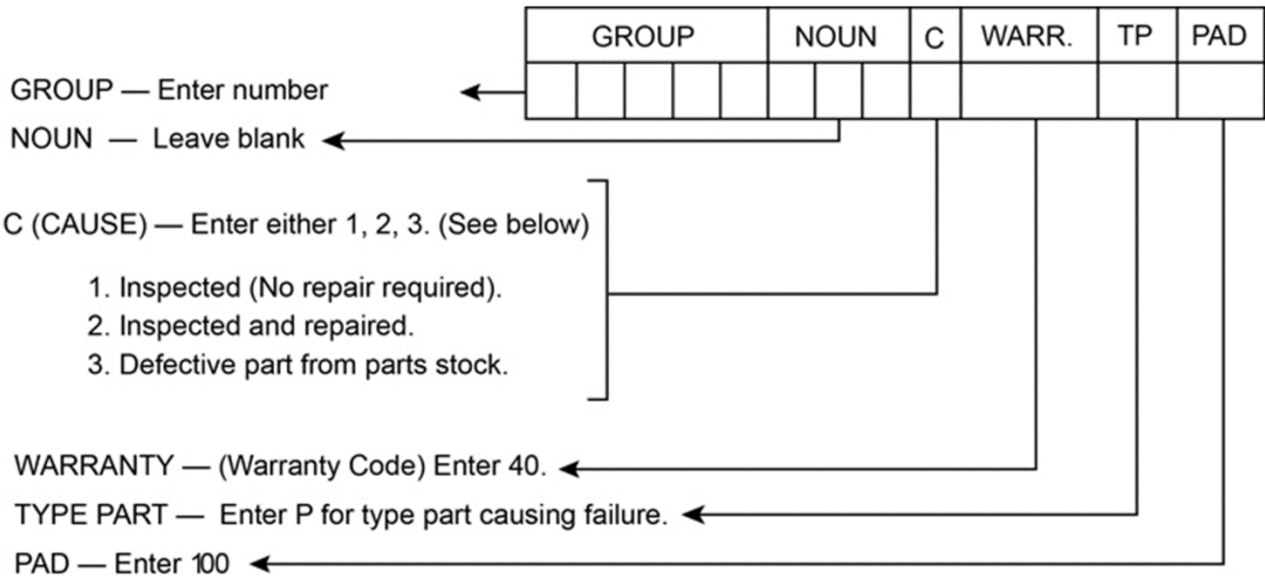

0000047910