



<b>Countries:</b>	RUSSIA, AUSTRALIA, CANADA, UNITED STATES, MEXICO, NEW ZEALAND	<b>Document ID:</b>	IK1201253
<b>Availability:</b>	ISIS, FleetISIS	<b>Revision:</b>	4
<b>Major System:</b>	ENGINES	<b>Created:</b>	1/8/2015
<b>Current Language:</b>	English	<b>Last Modified:</b>	11/16/2015
<b>Other Languages:</b>	NONE	<b>Author:</b>	Ben Krejcie
<b>Viewed:</b>	4071		

[Less Info](#)

Hide Details

Coding Information

<b>Copy Link</b> 	<b>Copy Relative Link</b> 	<b>Bookmark</b>  <a href="#">View My Bookmarks</a>	<b>Add to Favorites</b> 	<b>Print</b> 	<b>Provide Feedback</b> 	<b>Helpful</b>  27	<b>Not Helpful</b>  0
----------------------	-------------------------------	--	-----------------------------	------------------	-----------------------------	--------------------------	-----------------------------

**Title: Big Bore Exhaust Manifold Service Procedures**

**Applies To: EPA 10 MaxxForce 11, 13 and N13 Engines**

## CHANGE LOG

- 2015/11/16 - Revised exhaust manifold gasket note
- 2015/11/09 - New picture Figure 31 to show use of only 1 clamp during installation
- 2015/10/07 - Updated torque spec for bellows tubes and heat shields
- 2015/10/05 - Fixed wording for step 19 (new bolts are Hex heads not Torx), Updated SRT table/formatting
- 2015/08/25 - Initial Article Release

## DESCRIPTION

This document will guide the user through step based procedures for troubleshooting and part replacement for exhaust manifold repairs.

This document replaces/retires:

- IK1200883
- TSI-13-12-10
- TSI-13-12-12

## SYMPTOMS

**Diagnostic Trouble Codes:**

Not Applicable

**Customer Observations or Concerns:**

- Visible soot around the slip joints of the exhaust manifold
- Visible soot at the cylinder head to exhaust manifold interface
- Exhaust odor present in the cab
- Possible low power

## SPECIAL TOOLS

Tool Description	Tool Number	Comments	Instructions
Coolant Management System	KL5007NAV		<a href="#">Link</a>

[Tools Resource Center](#)

## SERVICE PARTS INFORMATION

Kit Description	Part Number	Qty	Notes

Kit, Rear Exhaust Manifold Seal	2512186C91	1	As Required
Manifold, Exhaust Rear	3005196C2	1	As Required
Manifold, Exhaust Rear	3018581C1	1	New, Thicker Flange
Manifold, Exhaust Middle	3018582C1	1	New, Thicker Flange
Manifold, Exhaust Front	3018583C1	1	New, Thicker Flange
Kit, Fey Rings (11L & 13L)	3007423C92	1 or 2	As Required
Kit, Rear Exhaust Manifold Seal	2512878C91	1	Rear manifold bolt, spacer and gasket kit for thicker flange only
Kit, Exhaust Bolts w/ Gaskets	2512877C91	1	Full manifold bolt, spacer and gasket kit for thicker flange only
Kit, Cowl Tray	2511806C91	1	As Required

## DIAGNOSTIC STEPS

**NOTE:**

These diagnostic steps should be used if the driver has stated there is an exhaust odor in the cab while the engine is running or if soot has been identified around the exhaust manifold during routine maintenance or during another repair.

Step	Action	Decision
1	<b>Inspect engine for exhaust leaks/visible soot:</b> Is there an exhaust leak (visible soot) at the cylinder head to manifold joint at cylinder 5 and/or cylinder 6?	<b>Yes.</b> Proceed to step 2
		<b>No.</b> Proceed to step 3

Step	Action	Decision
2	<b>Inspect engine for exhaust leaks/visible soot:</b> Is there an exhaust leak (visible soot) at the cylinder head to manifold joint at any other cylinder besides 5 and/or 6?	<b>Yes.</b> Perform complete manifold replacement procedure then proceed to step 5
		<b>No.</b> Perform rear manifold replacement procedure then proceed to step 5

Step	Action	Decision
3	<b>Inspect engine for exhaust leaks/visible soot:</b> Is there an exhaust leak (visible soot) at the cylinder head to manifold joint at any other cylinder besides 5 and/or 6?	<b>Yes.</b> Perform complete manifold replacement procedure then proceed to step 5
		<b>No.</b> Proceed to step 4

Step	Action	Decision
------	--------	----------

<b>4</b>	<b>Inspect engine for exhaust leaks/visible soot:</b> Is there an exhaust leak (visible soot) at the exhaust manifold slip joints, the connections between the front and middle or middle and rear exhaust manifold pieces.	<b>Yes.</b> Perform exhaust cuff procedure then proceed to step 5
		<b>No.</b> Proceed to step 5

Step	Action	Decision
<b>5</b>	<b>Odor in cab:</b> If the driver has stated there is an odor in the cab inspect the hot side tubes (bellows) for cracks. Are the tube cracked?	<b>Yes.</b> Replace tubes per service manual then proceed to step 6
		<b>No.</b> Proceed to step 6

Step	Action
<b>6</b>	<b>Odor in cab:</b> If the driver has stated there is an odor in the cab perform the cowl tray repair procedure

## OVERVIEW

- Updated exhaust manifolds released (3018583C1, 3018582C1 and 3018581C1) which have thicker flanges and requires different gaskets, bolts and spacers
  - If **ONLY** replacing the rear section manifold you may use the thicker/updated flange manifold (3018581C1) which replaces the old rear manifold (3005196C2), in combination with the original front and center manifold sections
  - If the front or center section manifold needs replacement, and all sections are the "thinner" flange, replace all 3 sections to the thicker/updated flange manifold following the service procedures in the Engine Service Manual

## REPAIR STEPS

### **Rear (#5 and #6) Exhaust Manifold Removal and Installation**

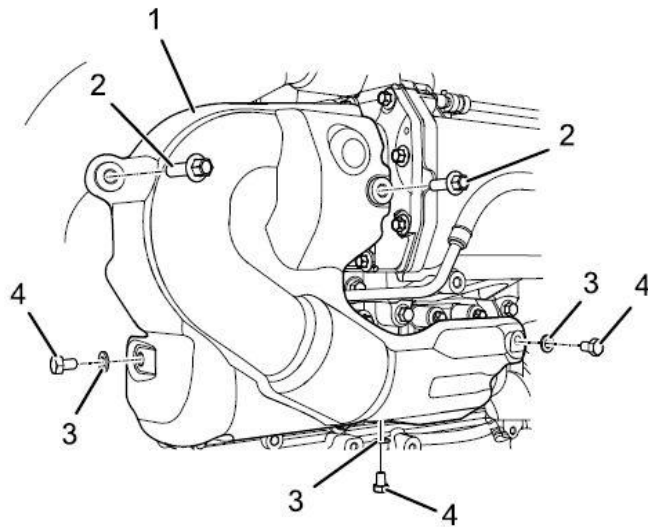
1. Bring truck into shop and park on flat surface.
2. Shift transmission to Park or Neutral, set parking brake, and install wheel chocks.
3. Unlatch and open hood.
4. Using Navistar Coolant Management Tool KL5007NAV, drain coolant.

**NOTE:**

**To access rear exhaust manifold, remove engine cover. Refer to the proper CAB Service Manual for the model of truck being serviced.**

5. Remove engine cover.
6. Disconnect Aftertreatment Fuel Injector (AFI) coolant supply tube from EGR coolant crossover manifold and cap fitting.

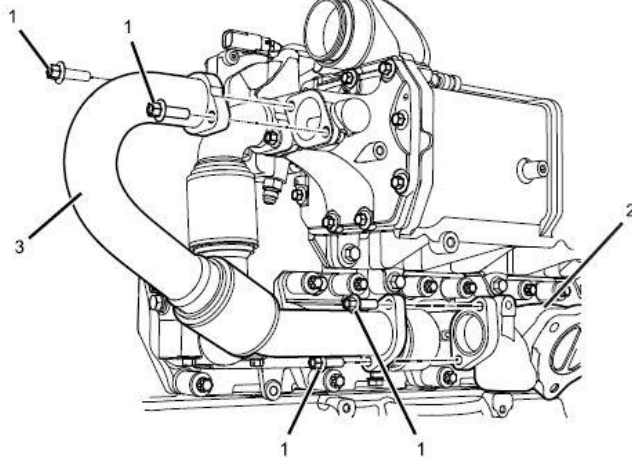




**Figure 1: Heat Shield (Cylinders 4 - 6)**

- Item 1: Heat shield (cylinders 4 - 6)
- Item 2: M8 x 25 heat-resistant bolt (2)
- Item 3: 8.4 x 16 x 1.6 washer (3)
- Item 4: M8 x 12 bolt (3)

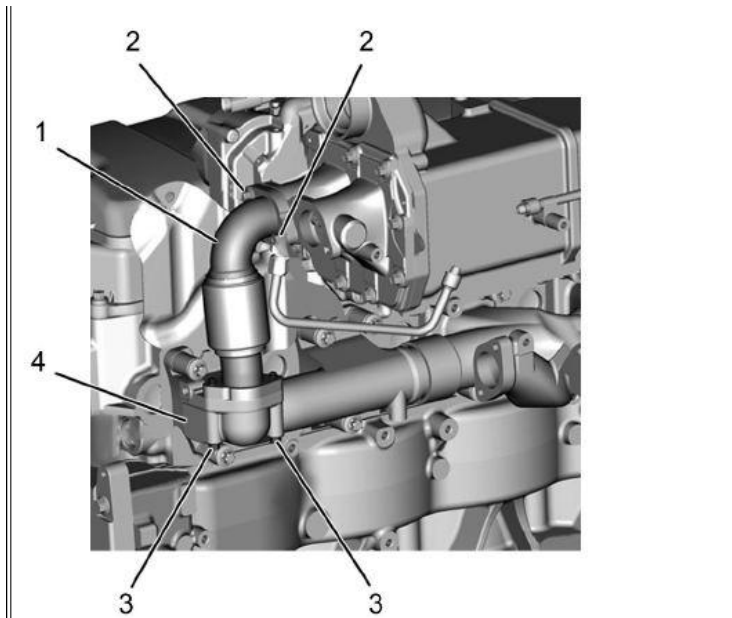
7. Remove heat shield (cylinders 4 - 6) (**Figure 1**, Item 1).



**Figure 2: Outboard EGR Inlet Tube**

- Item 1: M8 x 25 heat-resistant bolt (4)
- Item 2: Middle exhaust manifold
- Item 3: EGR inlet tube (cylinders 1 - 3)

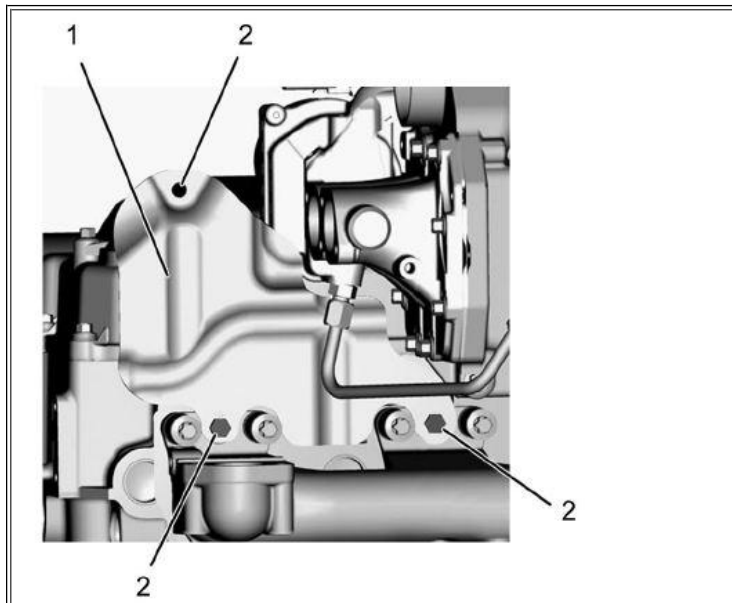
8. Remove outboard EGR inlet tube and two gaskets (**Figure 2**, Item 3). Discard gaskets and bolts (**Figure 2**, Item 1).



**Figure 3: Inboard EGR Inlet Tube**

Item 1: Inboard EGR inlet tube  
 Item 2: M8 x 25 heat-resistant bolt (2)  
 Item 3: Heat-resistant bolt (2)  
 Item 4: Rear exhaust manifold

9. Remove inboard EGR inlet tube and two tube gaskets (**Figure 3**, Item 1) . Discard gaskets and bolts (**Figure 3**, Items 2 & 3)

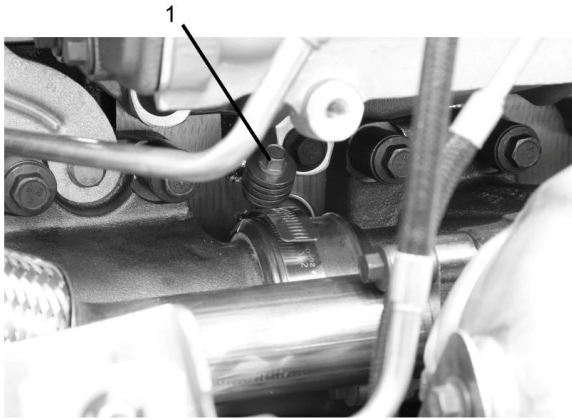


**Figure 4: EGR Heat Shield**

Item 1: EGR heat shield  
 Item 2: M8 x 12 bolt (3)

10. Remove EGR heat shield (**Figure 4**, Item 1).

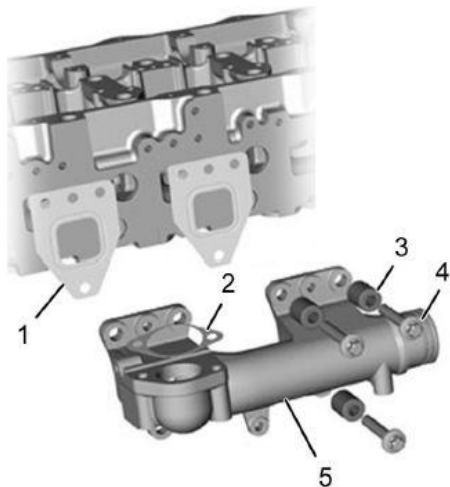




**Figure 5: Rear Exhaust Manifold Ring Seal**

Item 1: Ring seal clamp #1

11. If engine is equipped with an exhaust manifold ring seal, remove and discard (**Figure 5**, Item 1)



**Figure 6: Rear Exhaust Manifold**

Item 1: Exhaust manifold gasket (2)  
 Item 2: EGR tube gasket  
 Item 3: Sleeve spacer (6)  
 Item 4: Torx® bolt (6)  
 Item 5: Rear exhaust manifold

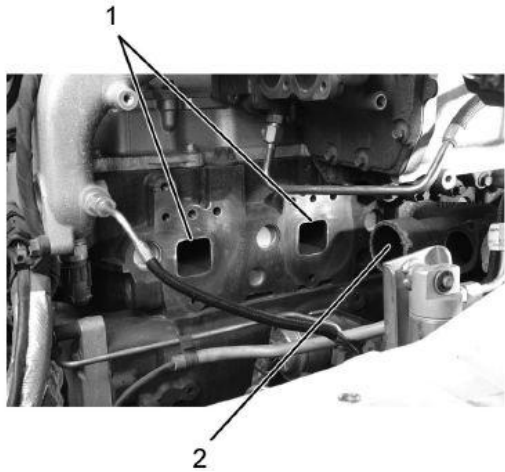
13. Separate rear exhaust manifold (**Figure 6**, Item 5) section from middle exhaust manifold.

**NOTE:**

**Do not use air tools or abrasive pads to clean parts. Rear exhaust manifold sealing surfaces may be cleaned with steam or suitable non-caustic solvents.**

14. Clean rear exhaust manifold gasket sealing surfaces.





**Figure 7: Cylinder Head**

- Item 1: #5 and #6 exhaust manifold gasket sealing surfaces
- Item 2: Middle exhaust manifold bore

15. Clean #5 and #6 exhaust manifold gasket sealing surfaces (**Figure 7**, Item 1) on cylinder head.

**NOTE:**

Exhaust leaks at the exhaust manifold joint will be resolved with the installation of the exhaust manifold ring seal kit. Any grooves or wear in the center section manifold do not need to be addressed.

16. Clean inside middle exhaust manifold bore (**Figure 7**, Item 2).

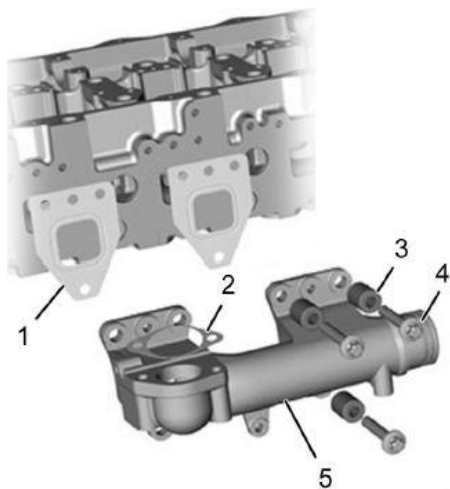
**CAUTION:**

To prevent engine damage, hand torque all fasteners of the exhaust manifolds. The exhaust manifold hardware has a special high-temperature coating that will be damaged by air tools.

**CAUTION:**

To prevent engine damage, do NOT reuse sleeve spacers or exhaust manifold bolts

17. Install rear exhaust manifold into middle exhaust manifold.



**Figure 8: Rear Exhaust Manifold**

- Item 1: Exhaust manifold gasket (2)
- Item 2: EGR tube gasket

Item 3: Sleeve spacer (6)  
 Item 4: Torx® bolt (6) (New bolts are Hex Heads)  
 Item 5: Rear exhaust manifold

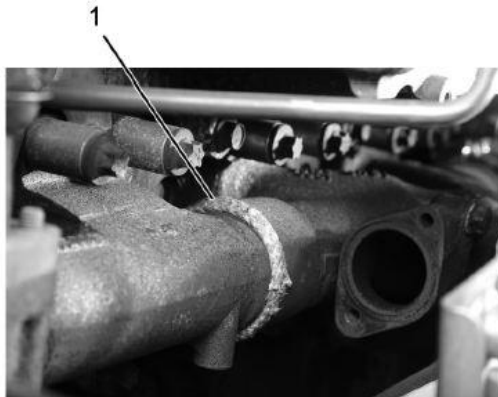
**NOTE:**

**The new exhaust manifold gasket is symmetric and can be installed in any orientation**

18. Position two new exhaust manifold gaskets (**Figure 8**, Item 1) and install rear exhaust manifold (**Figure 8**, Item 5) assembly.

19. Install six new Hex bolts and six new sleeve spacers included in kit 2512878C91 (**Figure 8**, Items 4 and 3)

20. Alternately tighten six new exhaust manifold bolts working from the inside - out and torque to **25 lb-ft (34 N•m)**, **recheck torque** and then turn bolts an additional **90 degrees**.

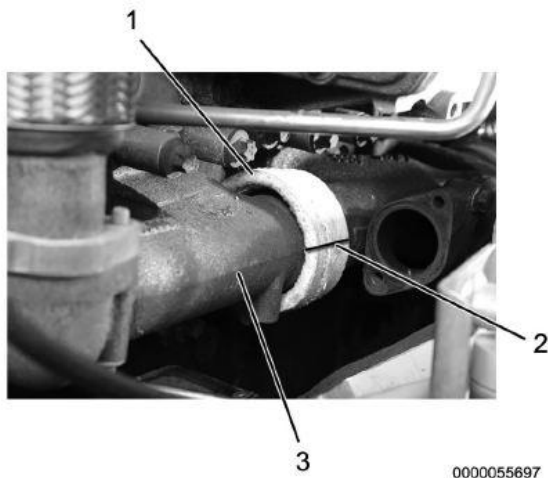


**Figure 9: Rear Exhaust Manifold Ring Seal Packing**

Item 1: Seal packing

21. Wrap seal packing (**Figure 9**, Item 1) around manifold ring joint and align so that seal ends meet at top of manifold.

22. Press seal packing tightly into joint with fingers.

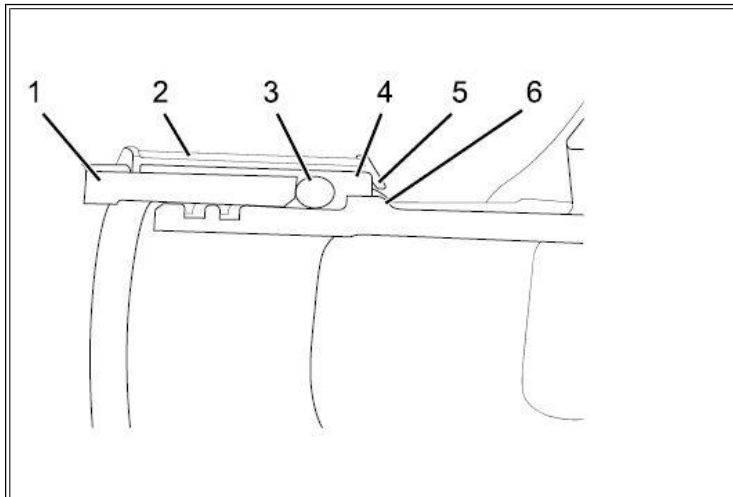


**Figure 10: Rear Exhaust Manifold Ring Seal Ceramic Mat Wrap**

Item 1: Ceramic mat wrap  
 Item 2: Ceramic mat wrap joint  
 Item 3: Manifold midpoint

23. Wrap manifolds and seal packing with ceramic mat wrap, covering seal packing with thick end of ceramic mat wrap (**Figure 10**, Item 1).

24. Align ceramic mat wrap joint (**Figure 10**, Item 2) with manifold midpoint (**Figure 10**, Item 3).



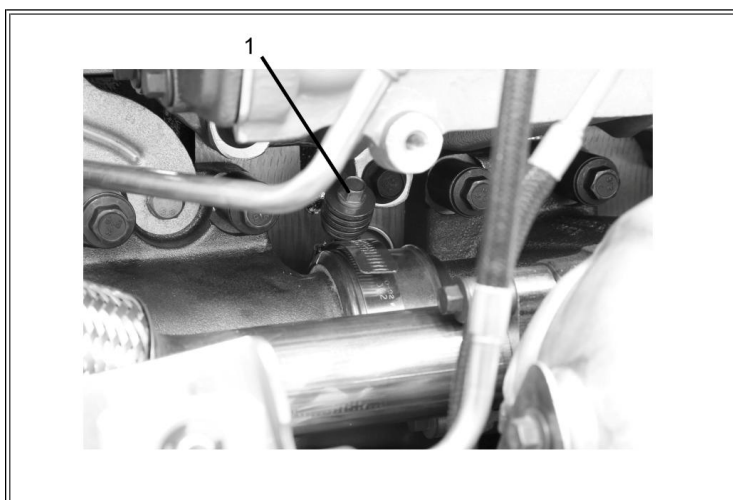
**Figure 11: Exhaust Manifold Ring Seal Cross Section**

Item 1: Female manifold  
 Item 2: Shield  
 Item 3: Seal packing  
 Item 4: Ceramic wrap  
 Item 5: Beveled flange  
 Item 6: Male manifold

### NOTE:

Verify shield completely covers ceramic mat wrap, and ceramic mat wrap overlaps seal packing (**Figure 11**)

25. Install two shield halves with beveled flange (**Figure 11**, Item 5) covering seal packing (**Figure 11**, Item 3) end, and align shield joint with manifold midpoint.



**Figure 12: Rear Exhaust Manifold Ring Seal**

Item 1: Ring seal clamp #1

### NOTE:

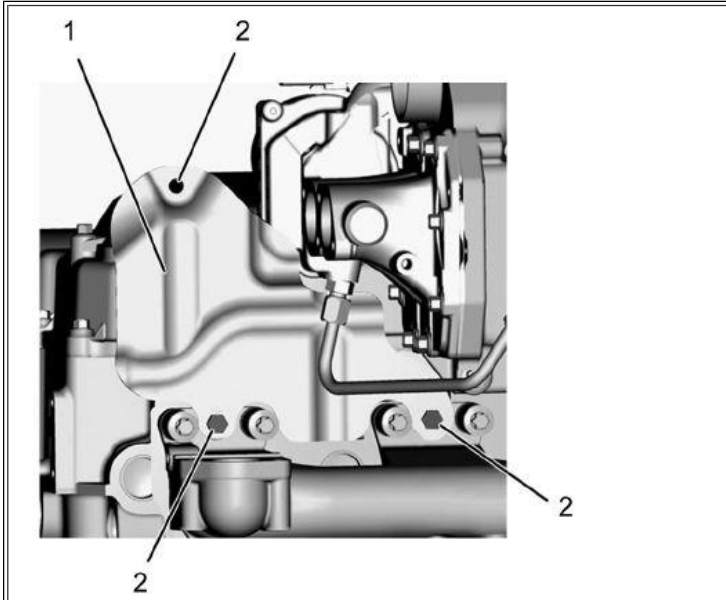
Ring seal clamp alignment must match the clamp alignment in **Figure 12** to prevent problems when installing the outboard EGR inlet tube.

26. Install #1 ring seal clamp (**Figure 12**, Item 1) center of shield.

27. Tighten #1 ring seal clamp to 2.58 lb-ft (3.5 N·m) while keeping the shield joint aligned with manifold midpoint.

### NOTE:

For complete heat shield (cylinders 4 - 6), EGR heat shield and EGR inlet tube installation procedures, refer to the appropriate Engine Service Manual.

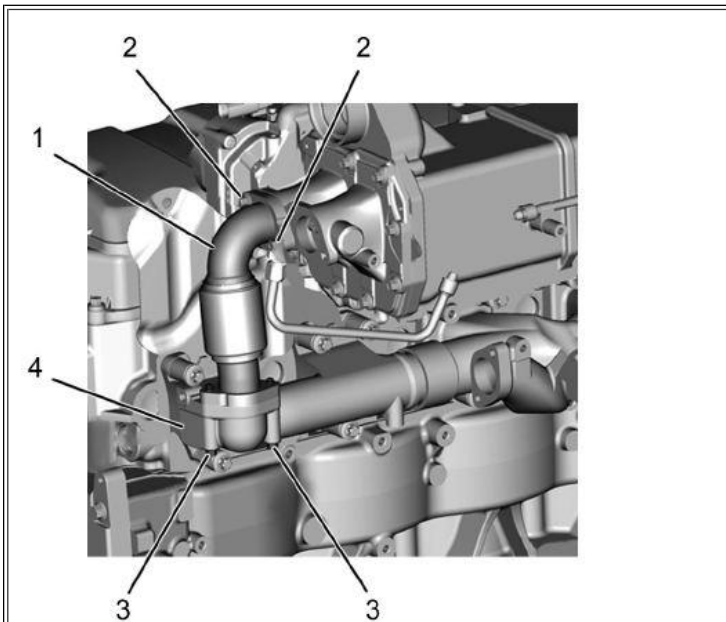


**Figure 13: EGR Heat Shield**

Item 1: EGR heat shield

Item 2: M8 x 12 bolt (3)

28. Install EGR heat shield (**Figure 13**, Item 1) with five M8 x 12 bolts (**Figure 13**, Item 2).



**Figure 14: Inboard EGR Inlet Tube**

Item 1: Inboard EGR inlet tube

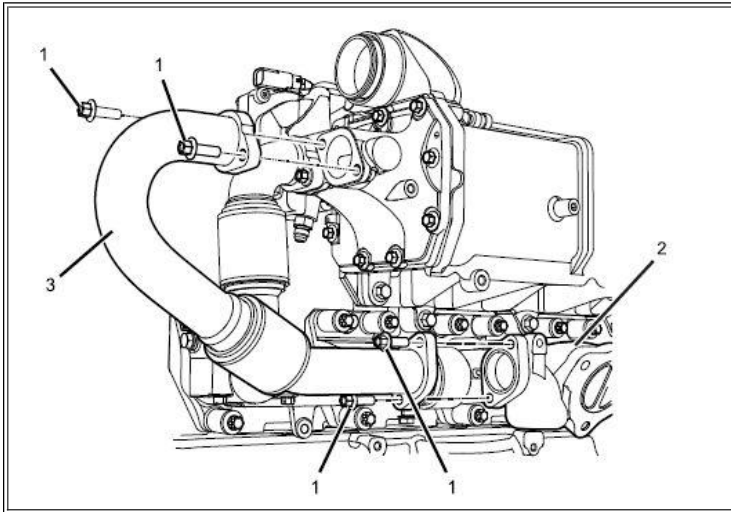
Item 2: M8 x 25 heat-resistant bolt (2)

Item 3: Heat-resistant bolt (2)

Item 4: Rear exhaust manifold

29. Position two new EGR inlet tube gaskets, one to EGR valve and one to rear exhaust manifold (**Figure 14**, Item 4).

30. Install inboard EGR inlet tube and tighten bolts (**Figure 14**, Items 2 and 3) to 18 lb-ft (24 N-m).



**Figure 15: Outboard EGR Inlet Tube**

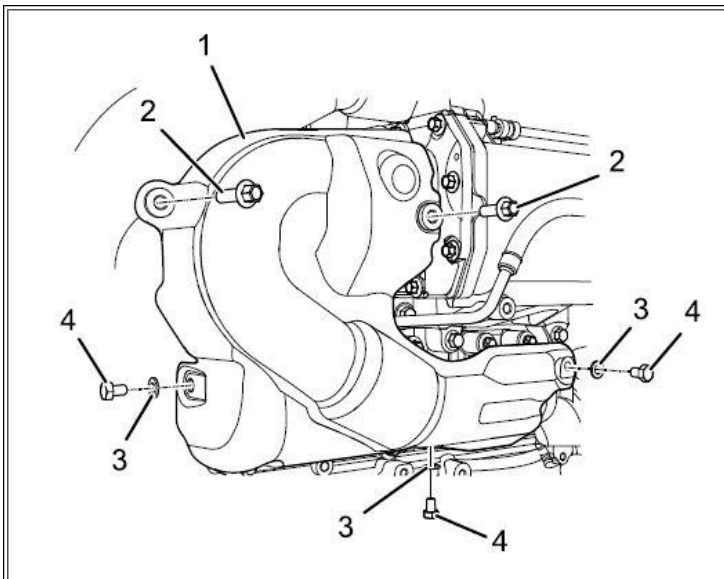
Item 1: M8 x 25 heat-resistant bolt (4)

Item 2: Middle exhaust manifold

Item 3: Outboard EGR inlet tube

31. Position two new EGR inlet tube gaskets, one to EGR valve and one to middle exhaust manifold (**Figure 15**, Item 2).

32. Install outboard EGR inlet tube and tighten bolts (**Figure 15**, Item 1) to 18 lb-ft (24 N-m).



**Figure 16: Heat Shield (Cylinders 4 - 6)**

Item 1: Heat shield (cylinders 4 - 6)

Item 2: M8 x 25 heat-resistant bolt (2)

Item 3: 8.4 x 16 x 1.6 washer (3)

Item 4: M8 x 12 bolt (3)

33. Install heat shield (Figure 16, Item 1). Tighten bolts to 23 lb-ft (31 N-m).

34. Uncap fitting and connect AFI coolant supply tube to EGR coolant crossover manifold. Torque to 23 lb-ft (31 N-m).

### NOTE:

For engine cover installation procedure, refer to proper CAB Service Manual for the model of truck being serviced.

35. Install engine cover.

36. Using Navistar Coolant Management Tool KL5007NAV, fill cooling system. Verify coolant is between MIN and MAX line of deaeration tank. Add coolant as required.

37. Close and latch hood.

38. Remove wheel chocks.

### Front Exhaust Manifold Ring Seal (Cuff) Removal / Installation

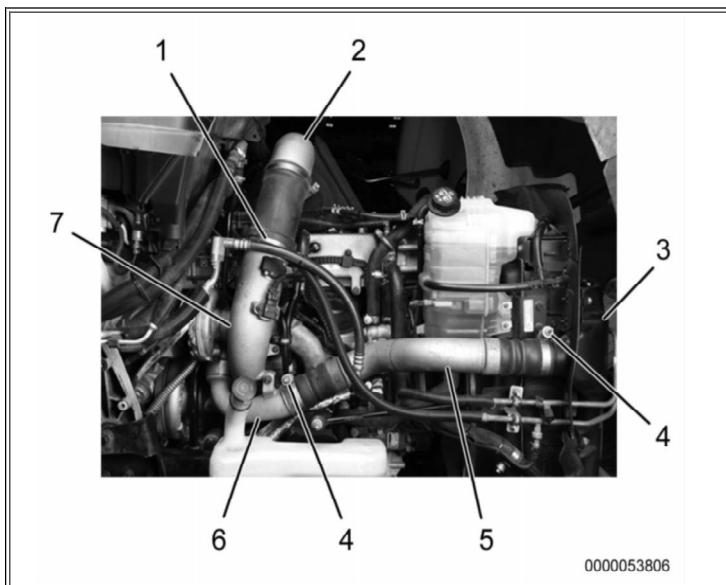
1. Bring truck into shop and park on flat surface.

2. Shift transmission to Park or Neutral, set parking brake and block wheels

3. Unlatch and open hood

#### NOTE:

**Do NOT drain coolant and disconnect AFI coolant supply line when servicing the front exhaust manifold ring seal.**



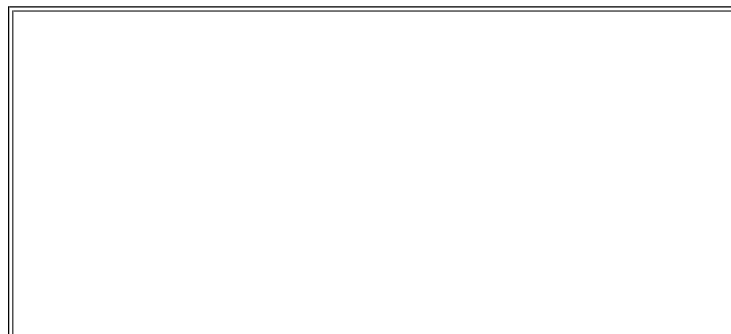
**Figure 17: HP Turbocharger Connections**

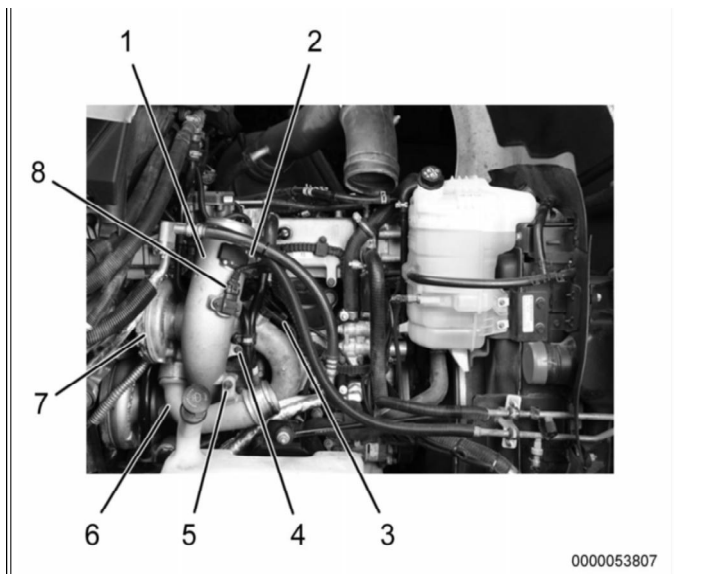
Item 1: Air inlet duct clamp  
 Item 2: Air inlet duct  
 Item 3: HPCAC  
 Item 4: HPCAC clamp (2)  
 Item 5: HPCAC pipe  
 Item 6: HP turbocharger outlet duct  
 Item 7: LP turbocharger inlet duct

4. Remove air inlet duct clamp (**Figure 17**, Item 1) and remove air inlet duct (**Figure 17**, Item 2) from Low-Pressure (LP) turbocharger inlet duct (**Figure 17**, Item 7)

5. Remove two High-Pressure Charge Air Cooler (HPCAC) clamps (**Figure 17**, Item 4) and remove HPCAC pipe (**Figure 17**, Item 5) from HPCAC (**Figure 17**, Item 3) and HP turbocharger outlet duct (**Figure 17**, Item 6).

6. Install cap on HPCAC.



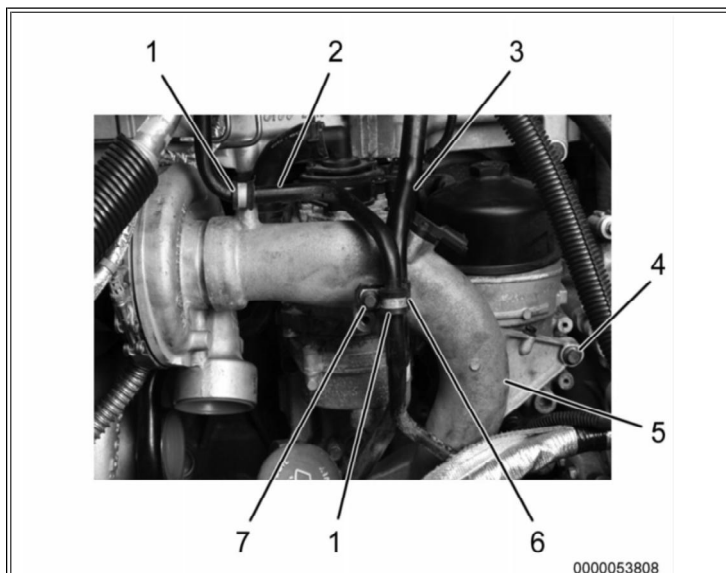


0000053807

**Figure 18: HP and LP Turbocharger Connections**

- Item 1: LP turbocharger inlet duct
- Item 2: MAF sensor connector
- Item 3: TC2CIP sensor connector
- Item 4: LP turbocharger inlet duct bolt (2)
- Item 5: HP turbocharger outlet duct bolt (2)
- Item 6: HP turbocharger outlet duct
- Item 7: HP turbocharger
- Item 8: AIT sensor connector

7. If equipped, disconnect Mass Air Flow (MAF) sensor connector (**Figure 18**, Item 2)
8. Disconnect Turbocharger 2 Compressor Inlet Pressure (TC2CIP) sensor connector (**Figure 18**, Item 3)
9. Disconnect Air Inlet Temperature (AIT) sensor connector (**Figure 18**, Item 8) and position engine harness aside.
10. Remove two HP turbocharger outlet duct bolts (**Figure 18**, Item 5) and HP turbocharger outlet duct (**Figure 18**, Item 6) from HP turbocharger (**Figure 18**, Item 7). Remove and discard O-ring seal.
11. Remove two LP turbocharger inlet duct bolts (**Figure 18**, Item 4) and LP turbocharger inlet duct (**Figure 18**, Item 1) from LP turbocharger. Remove and discard O-ring Seal
12. Install plugs in turbocharger openings.



0000053808

**Figure 19: Coolant Supply Tubes**

- Item 1: Coolant return tube P-clamp (2)
- Item 2: Coolant return tube
- Item 3: Coolant supply tube
- Item 4: HP turbocharger inlet duct bolt (2)
- Item 5: HP turbocharger inlet duct

Item 6: Coolant supply tube P-clamp  
Item 7: Coolant tube P-clamp bolt (2)

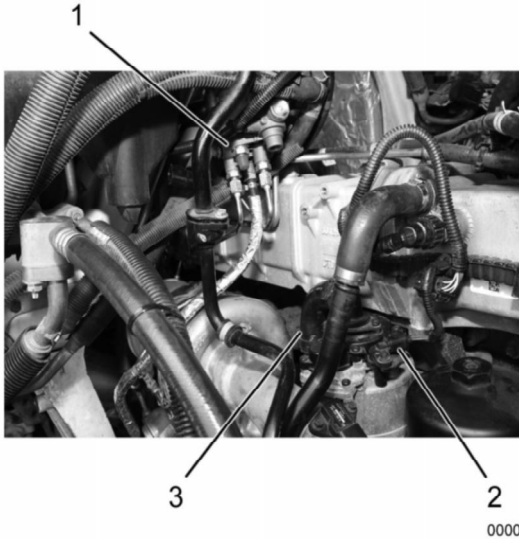
13. Remove two coolant tube P-clamps (**Figure 19**, Item 7) from two coolant return tube P-clamps (**Figure 19**, Item 1), coolant supply tube P-clamp (**Figure 19**, Item 6), coolant return tube (**Figure 19**, Item 2) and coolant supply tube (**Figure 19**, Item 3).

14. Position coolant return tube (**Figure 19**, Item 2) and coolant supply tube (**Figure 19**, Item 3) aside.

**NOTE:**

The lower HP turbocharger inlet duct bolt does not come all the way out due to interference with the washer reservoir. Removal of the washer reservoir is not required.

15. Remove two HP turbocharger inlet duct bolts (**Figure 19**, Item 4) from HP turbocharger inlet duct (**Figure 19**, Item 5).



**Figure 20: Air Control Valve**

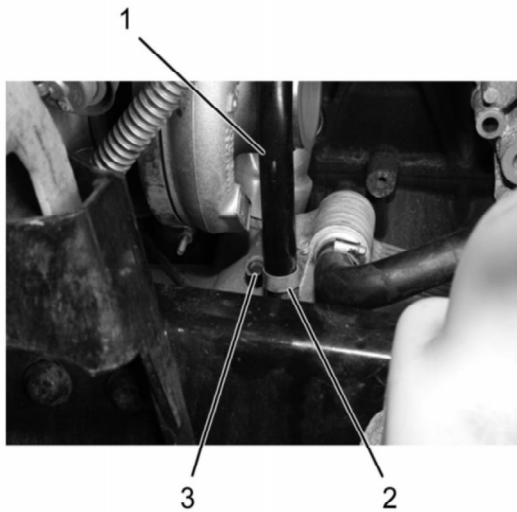
Item 1: ACV  
Item 2: CCOS housing sensor connector  
Item 3: CCOS housing outlet hose

16. Disconnect air supply line from Air Control Valve (ACV)

17. Remove three mounting bolts from ACV (**Figure 20**, Item 1) and position ACV aside.

18. Disconnect CCOS housing outlet hose (**Figure 20**, Item 3) from CCOS housing.

19. Disconnect CCOS housing sensor connector (**Figure 20**, Item 2).

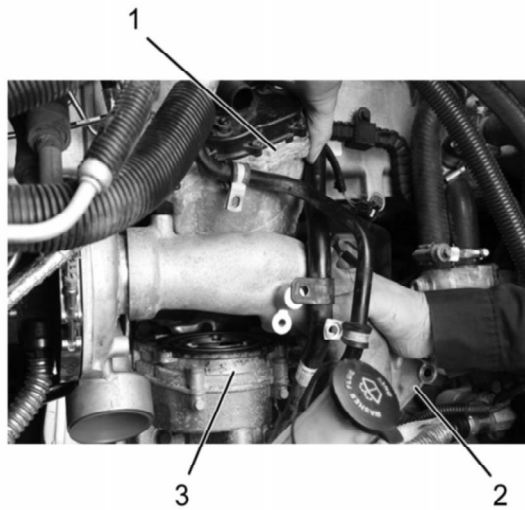


0000053809

**Figure 21: Crankcase Breather Tube**

Item 1: Crankcase breather tube  
 Item 2: Clamp  
 Item 3: Bolt

20. Remove bolt (**Figure 21**, Item 3) from clamp (**Figure 21**, Item 2) and position crankcase breather tube (**Figure 21**, Item 1) aside.



0000053811

**Figure 22: CCOS Housing**

Item 1: CCOS housing  
 Item 2: HP turbocharger inlet duct  
 Item 3: Oil jet plate

**NOTE:**

**Do NOT remove the four Torx bolts from the oil jet plate**

21. Remove three CCOS housing bolts from CCOS housing (**Figure 22**, Item 1) and oil jet plate (**Figure 22**, Item 3)

**NOTE:**

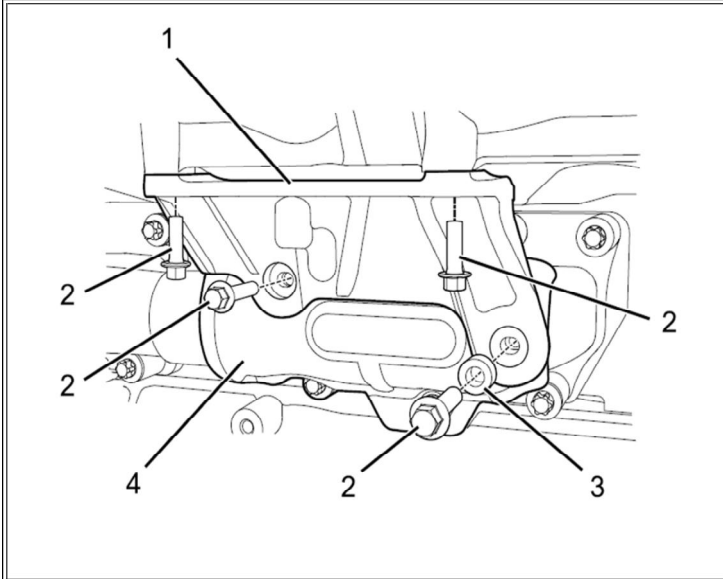
**While pulling out on the HP turbocharger inlet duct, maneuver and remove the COOS housing up and out (**Figure 22**).**

22. While pulling out HP turbocharger inlet duct (Figure 20, Item 2) remove CCOS housing (Figure 20, Item 1) from oil jet plate.

23. Cover CCOS mount openings with shop towel.

**NOTE:**

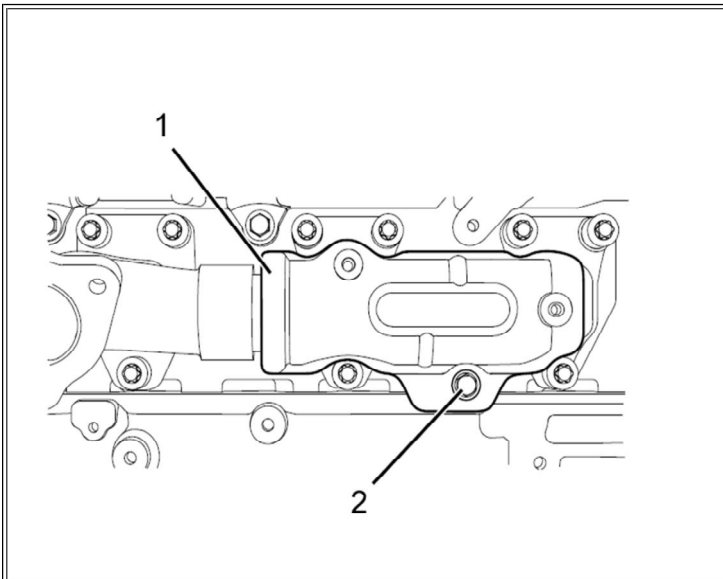
For complete EGR cooler L-bracket and exhaust manifold heat shield removal procedures, refer to MaxxForce 11 and 13 Engine Service Manual



**Figure 23: EGR Cooler L-Bracket**

- Item 1: EGR cooler L-bracket
- Item 2: M8 x 25 heat-resistant bolt (4)
- Item 3: Spacer
- Item 4: Exhaust manifold heat shield

24. Remove EGR cooler L-bracket (Figure 23, Item 1)

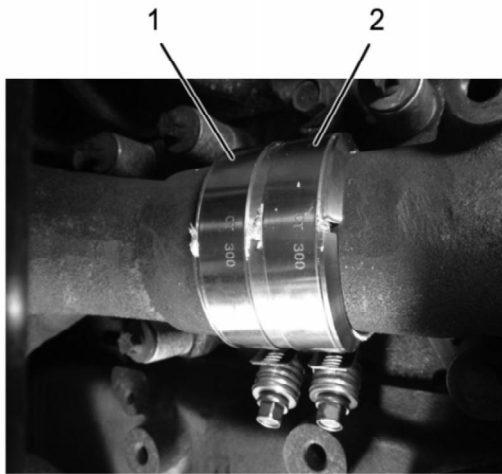


**Figure 24: Exhaust Manifold Heat Shield**

- Item 1: Exhaust manifold heat shield
- Item 2: M8 x 12 bolt

25. Remove exhaust manifold heat shield (Figure 24, Item 1)





**Figure 25: Front Exhaust Manifold Ring Seal**

Item 1: Ring seal clamp #1  
Item 2: Ring seal clamp #2

26. Remove and discard failed front exhaust manifold ring seal(s) if applicable (**Figure 25**, Items 1&2)

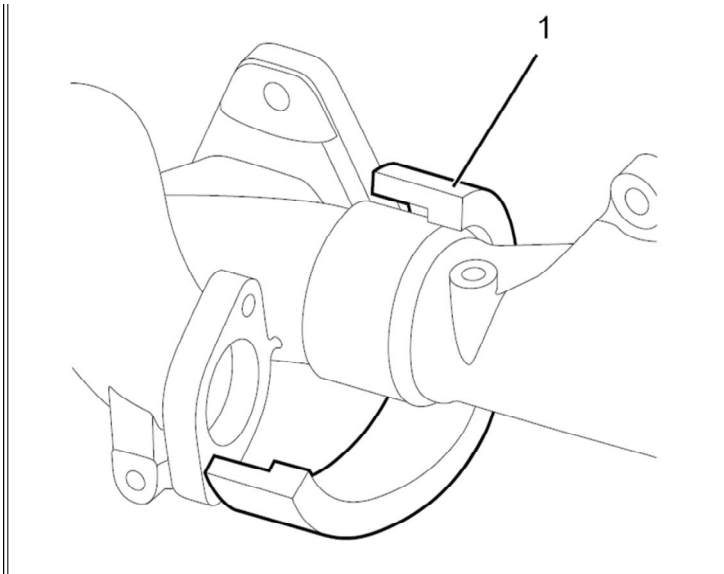


**Figure 26: Front Exhaust Manifold Ring Seal Packing**

Item 1: Seal packing

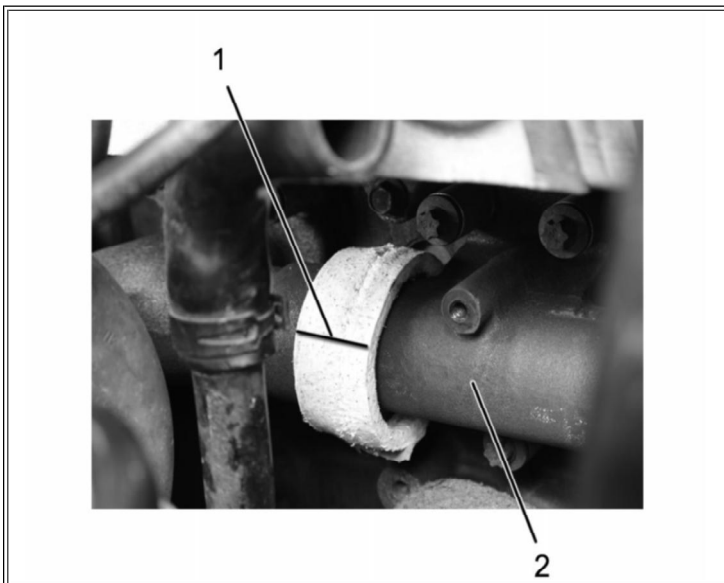
27. Wrap seal packing (**Figure 26**, Item 1) around manifold ring joint and align so that seal ends meet at top of manifold

28. Press seal packing tightly into joint with fingers



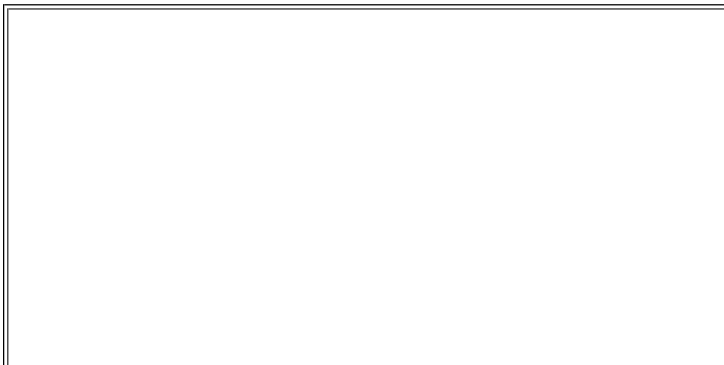
**Figure 27: Front Exhaust Manifold Ring Seal Ceramic Mat Wrap**  
 Item 1: Ceramic mat wrap

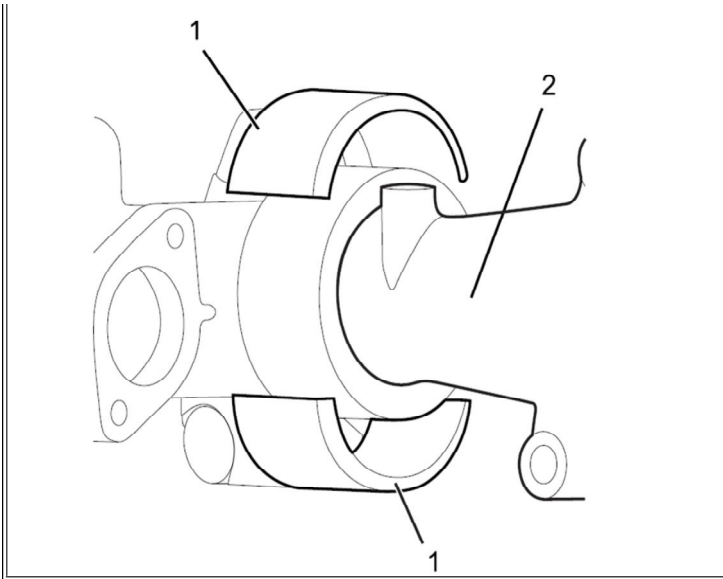
29. Wrap manifolds and seal packing with ceramic mat wrap (Figure 27, Item 1) covering seal packing with thick end of ceramic mat wrap.



**Figure 28: Front Exhaust Manifold Ring Seal Ceramic Mat Wrap Alignment**  
 Item 1: Ceramic mat wrap join  
 Item 2: Manifold midpoint

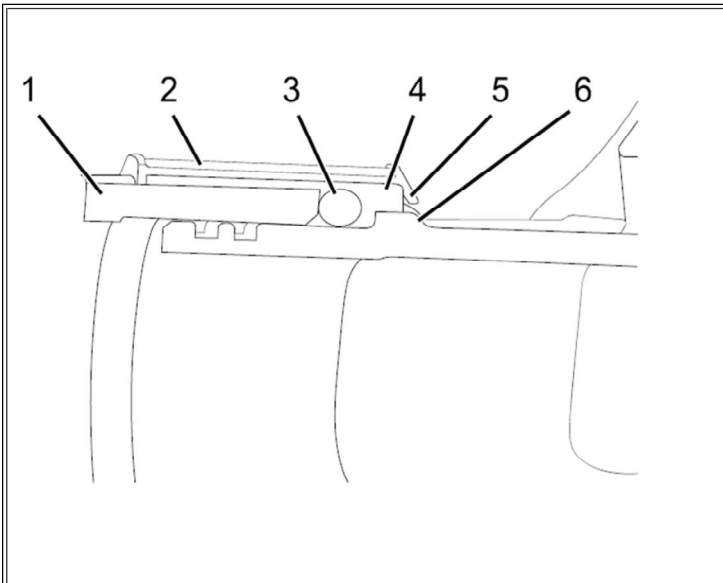
30. Align ceramic mat wrap joint (Figure 28, Item 1) with manifold midpoint (Figure 28, Item 2)





**Figure 29: Front Exhaust Manifold Ring Seal Shields**

- Item 1: Beveled flange
- Item 2: Manifold midpoint



**Figure 30: Exhaust Manifold Ring Seal Cross Section**

- Item 1: Female manifold
- Item 2: Shield
- Item 3: Seal packing
- Item 4: Ceramic wrap
- Item 5: Beveled flange
- Item 6: Male manifold

**NOTE:**

**Verify shield completely covers ceramic mat wrap, and ceramic mat wrap overlaps seal packing (Figure 30)**

31. Install two shield halves with beveled flange (Figure 29, Item 1) on seal packing end and align join with manifold midpoint.





Figure 31: Exhaust Manifold Ring Seal/Clamp

**NOTE:**

Ring seal clamp alignment must match the clamp alignment in to prevent problems when installing the exhaust manifold heat shield.

- 32. Install ring seal clamp (Figure 31) center of shield.
- 33. Tighten 1 ring seal clamp to 2.58 lb-ft (3.5 N•m) while keeping the shield joint aligned with manifold midpoint.

**NOTE:**

For complete EGR cooler L-bracket and exhaust manifold heat shield installation procedures and torque specifications, refer to MaxxForce 11 and 13 Engine service Manual.

**Full Exhaust Manifold Replacement/Installation**

Please follow the service procedures within the Service Manual to remove and install the front, center and rear manifold sections

**WARRANTY INFORMATION**

Warranty Claim Coding:

<b>Group:</b>	12000 - Engine
<b>Noun:</b>	356 - Manifold Assembly, Exhaust 358 - Gasket, Exhaust Manifold 359 - Seal Ring, Exhaust Manifold

Standard Repair Times:

Step	Description	Chassis	Engine	SRT	Hours
	(complete) Exhaust Manifold and Gasket Replacement	WorkStar	EPA10 MaxxForce 11/13	<a href="#">N12-6356U</a>	<a href="#">Exhaust Manifold and/or Gasket, Replace</a>
			EPA10 N13	<a href="#">N12-6356US</a>	
		TranStar	EPA10 MaxxForce 11/13	<a href="#">Q12-6356U</a>	
			EPA10 N13	<a href="#">Q12-6356US</a>	
		ProStar	EPA10 MaxxForce 11/13	<a href="#">R12-6356U</a>	
			EPA10 N13	<a href="#">R12-6356US</a>	
		LoneStar	EPA10 MaxxForce 11/13	<a href="#">S12-6356U</a>	
			EPA10 N13	<a href="#">S12-6356US</a>	
		PayStar	EPA10 MaxxForce 11/13	<a href="#">T12-6356U</a>	
			EPA10 N13	<a href="#">T12-6356US</a>	
CAT CT660	EPA10 N13	<a href="#">TC12-6356US</a>			
	Exhaust Manifold Gaskets (only) Replacement	WorkStar	EPA10 MaxxForce 11/13	<a href="#">N12-6358U</a>	<a href="#">Exhaust Manifold and/or Gasket, Replace</a>
			EPA10 N13	<a href="#">N12-6358US</a>	
		TranStar	EPA10 MaxxForce 11/13	<a href="#">Q12-6358U</a>	

			EPA10 N13	<a href="#">Q12-6358US</a>	
		ProStar	EPA10 MaxxFORCE 11/13	<a href="#">R12-6358U</a>	
			EPA10 N13	<a href="#">R12-6358US</a>	
		LoneStar	EPA10 MaxxFORCE 11/13	<a href="#">S12-6358U</a>	
			EPA10 N13	<a href="#">S12-6358US</a>	
		PayStar	EPA10 MaxxFORCE 11/13	<a href="#">T12-6358U</a>	
			EPA10 N13	<a href="#">T12-6358US</a>	
		CAT CT660	EPA10 N13	<a href="#">TC12-6358US</a>	
	Rear Section Manifold and/or Gasket Replacement	WorkStar	EPA10 MaxxFORCE 11/13	<a href="#">N12-6356U-21</a>	<a href="#">Rear Section Exhaust Manifold and/or Gasket, Replace</a>
			EPA10 N13	<a href="#">N12-6356US-21</a>	
		TranStar	EPA10 MaxxFORCE 11/13	<a href="#">Q12-6356U-21</a>	
			EPA10 N13	<a href="#">Q12-6356US-21</a>	
		ProStar	EPA10 MaxxFORCE 11/13	<a href="#">R12-6356U-21</a>	
			EPA10 N13	<a href="#">R12-6356US-21</a>	
		LoneStar	EPA10 MaxxFORCE 11/13	<a href="#">S12-6356U-21</a>	
			EPA10 N13	<a href="#">S12-6356US-21</a>	
		PayStar	EPA10 MaxxFORCE 11/13	<a href="#">T12-6356U-21</a>	
			EPA10 N13	<a href="#">T12-6356US-21</a>	
		CAT CT660	EPA10 N13	<a href="#">TC12-6356U-21</a>	
		Exhaust Manifold Ring Seal (Cuff) Install or Replace (FRONT)	WorkStar	EPA10 MaxxFORCE 11/13	
	EPA10 N13			<a href="#">N12-6356US-22</a>	
	TranStar		EPA10 MaxxFORCE 11/13	<a href="#">Q12-6356U-22</a>	
			EPA10 N13	<a href="#">Q12-6356US-22</a>	
	ProStar		EPA10 MaxxFORCE 11/13	<a href="#">R12-6356U-22</a>	
			EPA10 N13	<a href="#">R12-6356US-22</a>	
	LoneStar		EPA10 MaxxFORCE 11/13	<a href="#">S12-6356U-22</a>	
			EPA10 N13	<a href="#">S12-6356US-22</a>	
	PayStar		EPA10 MaxxFORCE 11/13	<a href="#">T12-6356U-22</a>	
			EPA10 N13	<a href="#">T12-6356US-22</a>	
	CAT CT660		EPA10 N13	<a href="#">TC12-6356U-22</a>	
	Exhaust Manifold Ring Seal (Cuff) Install or Replace (REAR)		WorkStar	EPA10 MaxxFORCE 11/13	<a href="#">N12-6356U-23</a>
		EPA10 N13		<a href="#">N12-6356US-23</a>	
		TranStar	EPA10 MaxxFORCE 11/13	<a href="#">Q12-6356U-23</a>	
			EPA10 N13	<a href="#">Q12-6356US-23</a>	
		ProStar	EPA10 MaxxFORCE 11/13	<a href="#">R12-6356U-23</a>	
			EPA10 N13	<a href="#">R12-6356US-23</a>	
		LoneStar	EPA10 MaxxFORCE 11/13	<a href="#">S12-6356U-23</a>	
			EPA10 N13	<a href="#">S12-6356US-23</a>	
		PayStar	EPA10 MaxxFORCE 11/13	<a href="#">T12-6356U-23</a>	
			EPA10 N13	<a href="#">T12-6356US-23</a>	
		CAT CT660	EPA10 N13	<a href="#">TC12-6356U-23</a>	
		Exhaust Manifold Ring Seal (Cuff) Install or Replace (FRONT AND REAR)	WorkStar	EPA10 MaxxFORCE 11/13	<a href="#">N12-6356U-24</a>
	EPA10 N13			<a href="#">N12-6356US-24</a>	
	TranStar		EPA10 MaxxFORCE 11/13	<a href="#">Q12-6356U-24</a>	
			EPA10 N13	<a href="#">Q12-6356US-24</a>	
	ProStar		EPA10 MaxxFORCE 11/13	<a href="#">R12-6356U-24</a>	
			EPA10 N13	<a href="#">R12-6356US-24</a>	
	LoneStar		EPA10 MaxxFORCE 11/13	<a href="#">S12-6356U-24</a>	
			EPA10 N13	<a href="#">S12-6356US-24</a>	
	PayStar		EPA10 MaxxFORCE 11/13	<a href="#">T12-6356U-24</a>	
			EPA10 N13	<a href="#">T12-6356US-24</a>	
	CAT CT660		EPA10 N13	<a href="#">TC12-6356U-24</a>	
	ADD-ON: Engine Cover Remove/Install		TranStar w/ Premium Interior	EPA10 MaxxFORCE 11/13	<a href="#">Q12-6356U-1</a>
		EPA10 N13		<a href="#">Q12-6356U-2</a>	

## OTHER RESOURCES

[Master Service Information Site](#)

 Hide Details

Feedback Information

Viewed: 4070  
Helpful: 27  
Not Helpful: 0

No Feedback Found

Copyright © 2015 Navistar, Inc.