



Countries: CANADA, UNITED STATES Document ID: IK0800512  
 Availability: Revision: 0  
 Major System: COOLING Created: 3/9/2015  
 Current Language: English Last Modified: 3/18/2015  
 Other Languages: NONE Author: Kevin Kochanek  
 Viewed: 58

[Less Info](#)

Hide Details

Coding Information

Copy Link 	Copy Relative Link 	Bookmark  <a href="#">View My Bookmarks</a>	Add to Favorites 	Print 	Provide Feedback 	Helpful  0	Not Helpful  0
---------------	------------------------	---	----------------------	-----------	----------------------	------------------	----------------------

Title: WorkStar Upper radiator Hose update

Applies To: WorkStars with Feature code 0012UAS and 2010 Emissions year MaxxForce DT

## CHANGE LOG

2015/03/18 - Initial Article Release

## DESCRIPTION

WorkStars built with cooling package feature code 0012UAS are experiencing upper radiator hose pulling off the outlet side at the radiator. In these cases it will be necessary to update the upper radiator hose. This document will guide through the process and information necessary for successful repair.

## SPECIAL TOOLS / SOFTWARE

Tool Description	Tool Number	Comments	Instructions
Navistar Coolant Management Tool	KL5007NAV		

[Service Tool Resource Center](#)

## SERVICE PARTS INFORMATION

Kit Description	Part Number	Qty	Notes
PIPE,RADIATOR , UPPER ASSY W/O	4055434C1	1	
HOSE,RAD INLET , N/ SENDURE	4055445C1	1	
CLAMP RAD HEAT SHRINK INLET	2506704C1	2	
CLAMP HOSE 2.50" ID	3519061C1	1	

## REPAIR STEPS

**WARNING!** To prevent property damage, personal injury, and / or death, park vehicle on a hard, flat surface, turn the engine off, set the parking brake, and install wheel chocks to prevent the vehicle from moving in either direction.

**WARNING!** To prevent property damage, personal injury, and / or death, if the vehicle must be raised, do not work under the vehicle supported only by jacks. Jacks can slip or fall over.

**WARNING!** To prevent personal injury and / or death, always wear safe eye protection when performing vehicle maintenance.

**WARNING!** To prevent property damage, personal injury, and / or death, keep flames or sparks away from vehicle and do not smoke while servicing the vehicle's batteries. Batteries expel explosive gases.

**WARNING!** To prevent property damage, personal injury, and / or death, remove the ground cable from the negative terminal of the battery box before disconnecting any electrical components. Always connect the ground cable last.

1. Bring vehicle into shop and park on flat surface.
2. Shift transmission to Park or Neutral, set parking brake, and install wheel chocks.
3. Check Service Portal, Perform all open AFCs and Safety Recalls, Warranty to be filed against AFC or Recall.
4. Remove battery box cover on driver side battery box, remove the ground cable from the negative terminal.
5. Unlatch and open hood.
6. Using Navistar Coolant Management Tool KL5007NAV, drain coolant from system. Place suitable drain pan under truck to collect any remaining coolant throughout procedure.

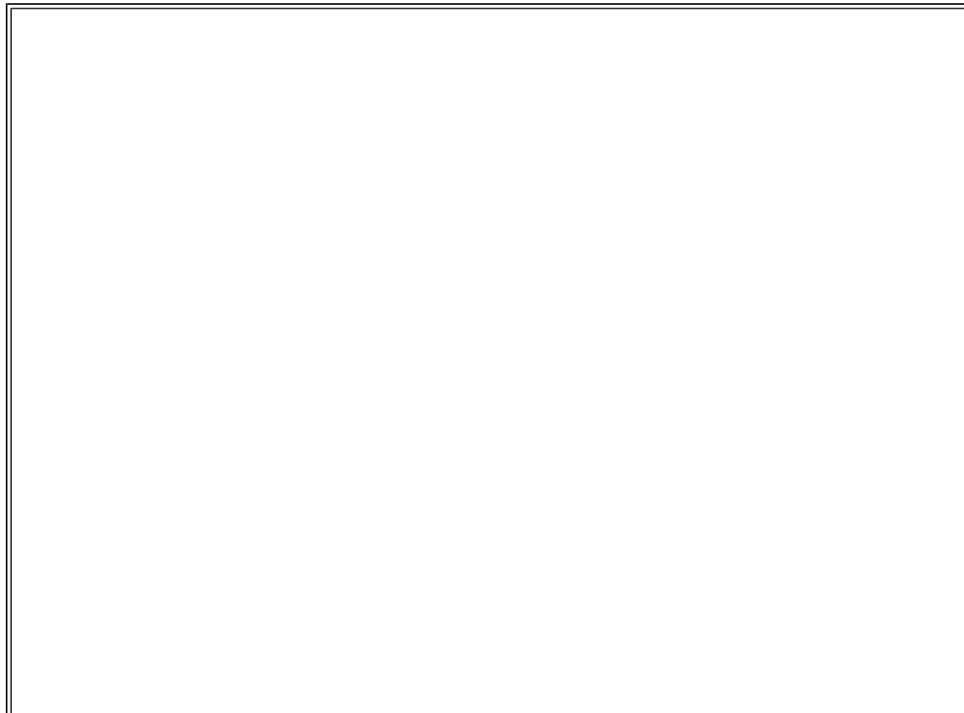

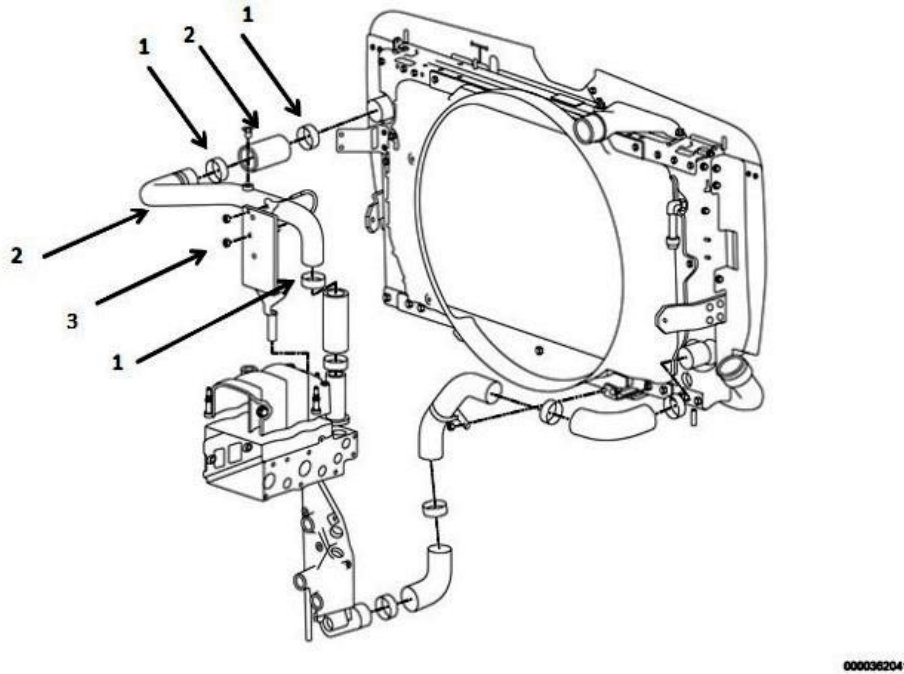

**Figure 1: Original Configuration**

Item 1: Hose Clamp

Item 2: Upper Radiator Pipe and Hoses

Item 3: U-Bolt

7. Remove three hose clamps from upper radiator pipe and hoses. Figure 1 item 1.
8. Remove two U-bolt nuts from U-bolt and remove mounting clamp. Figure 1 item 3.
9. Remove upper radiator pipe and hoses. Figure 1 item 2.

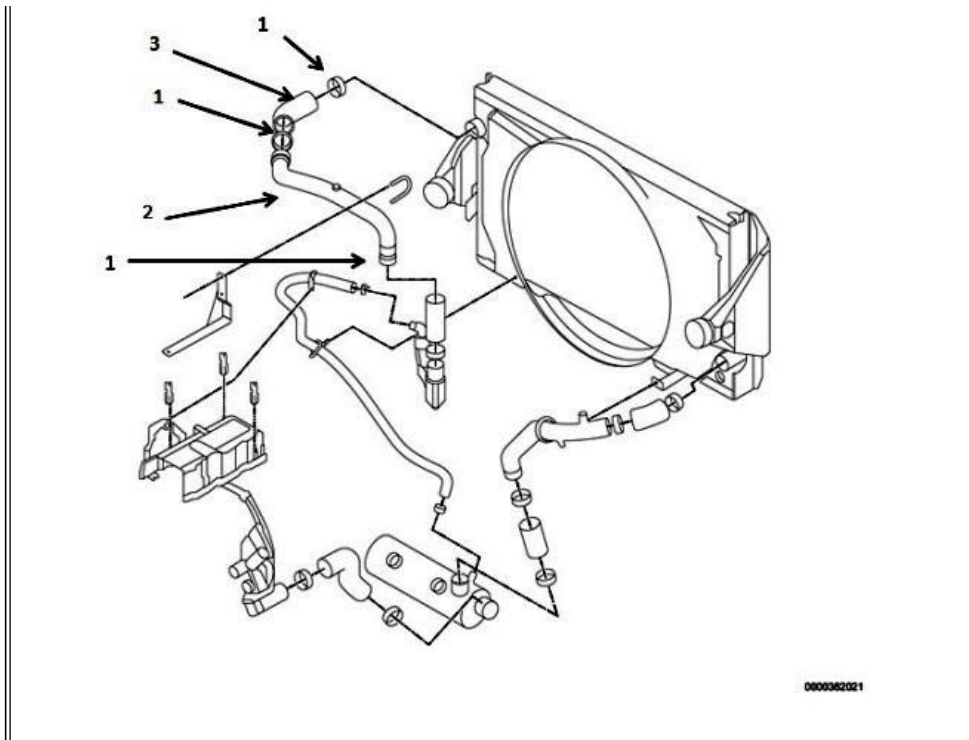

**Figure 2: Updated Configuration**

Item 1: Hose Clamp (T Bolt Clamp)  
 Item 2: Radiator Pipe  
 Item 3: Radiator Hose

10. Position upper radiator hoses on radiator pipe and secure with hose clamps. Figure 2 Item 2, and 3.
11. Install upper radiator hoses on radiator and engine.
12. Secure both ends of upper radiator hoses with hose clamps, at radiator use (T Bolt Clamp) . Figure 2 Item 1.
13. Secure upper radiator pipe to engine with U-bolt and two U-bolt nuts. Torque U-bolt nuts to 28 to 33 N•m (21 to 24 lbs-ft).
14. Inspect all hose connections prior to filling cooling system by trying to turn each hose. Hose and clamp should not turn when using reasonable torque.
15. Fill cooling system using Navistar Coolant Management Tool KL5007NAV.
16. Start vehicle to verify proper operation, no leaks, and no fault codes are present.
17. Close and latch hood.
18. Remove wheel chocks.

## **WARRANTY INFORMATION**

### **Warranty Claim Coding:**

<b>Group:</b>	09009 - Radiator
<b>Noun:</b>	189 - Clamp, Hose

**Standard Repair Times:**

Step	Description	SRT	Hours
All	Replace Upper Radiator Hose	T-time	0.8

---

## **OTHER RESOURCES**

[Master Service Information Site](#)

 Hide Details

**Feedback Information**

Viewed: 57  
 Helpful: 0  
 Not Helpful: 0

No Feedback Found