



Service Bulletin

PRELIMINARY INFORMATION

Subject: Growl Or Grind Noise - Front Differential Drive Pinion Gear - Or Differential Carrier Bearing

Models: 2015 Buick Enclave, LaCrosse, Regal
2015 Cadillac SRX, XTS
2015 Chevrolet Equinox, Impala, Malibu, Traverse
2015 GMC Acadia, Terrain
Equipped with 6T70 or 6T75 Automatic Transmission (RPOs M7U, M7V, M7W, M7X, MH2)

This PI was superseded to update Administrative Details. Please discard PIP5296.

The following diagnosis might be helpful if the vehicle exhibits the symptom(s) described in this PI.

Condition/Concern

Some customers may comment on a grind or growl noise from the transmission while moving. Disassembly of the transmission may find a Front Differential Drive Pinion Gear bearing(s) or Differential Carrier bearing(s) that are damaged.

Recommendation/Instructions

If a damaged Front Differential Drive Pinion Gear bearing(s) (480), SI# 1726803, and/or Differential Carrier bearing(s) (485, 487), SI# 1726804, are found please contact TAC prior to attempting to remove the distressed bearing(s) from Front Differential Drive Pinion (w/Transfer Gear) Gear Assembly, and/or the Front Differential Carrier Assembly. Do not proceed with any further repairs.

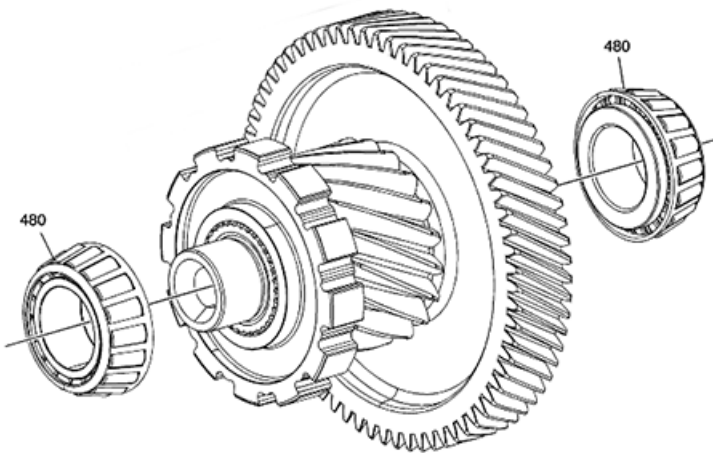

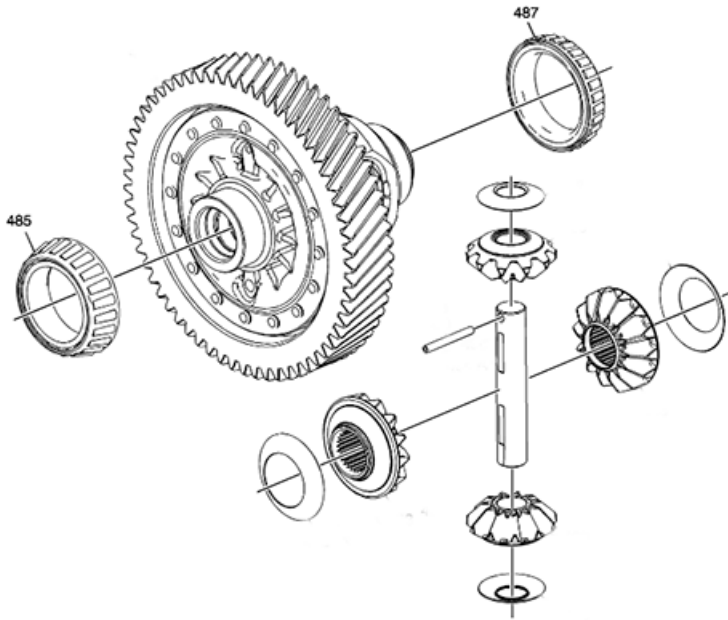

Please follow this diagnostic or repair process thoroughly and complete each step. If the condition exhibited is resolved without completing every step, the remaining steps do not need to be performed.

GM bulletins are intended for use by professional technicians, NOT a "do-it-yourselfer". They are written to inform these technicians of conditions that may occur on some vehicles, or to provide information that could assist in the proper service of a vehicle. Properly trained technicians have the equipment, tools, safety instructions, and know-how to do a job properly and safely. If a condition is described, DO NOT assume that the bulletin applies to your vehicle, or that your vehicle will have that condition. See your GM dealer for information on whether your vehicle may benefit from the information.



WE SUPPORT VOLUNTARY TECHNICIAN CERTIFICATION