



Service Bulletin

PRELIMINARY INFORMATION

Subject: Hood Shakes / Lifts On Sides Or Flutters At The Rear

Models: 2015 Chevrolet Colorado
2015 GMC Canyon

This PI was superseded to update Recommendation/Instructions. Please discard PIT5340.

The following diagnosis might be helpful if the vehicle exhibits the symptom(s) described in this PI.

Condition/Concern

The hood may shake or flutter while driving.

This could be caused by hood bumpers or the hood latch being out of adjustment.

Recommendation/Instructions

Perform the following tests to determine if the hood bumpers or latch require adjustment:

1. Open hood

Note: If the paper is placed over the headlamp it could give a false reading. The 4 outboard bumpers need the paper to be to the side of the headlamp and pulled over the fender. The 2 inboard bumpers need the paper to be to the front of the truck and pulled forward.

2. With a piece of paper, check all 6 bumpers with this paper test.

The 4 outboard bumpers must have good contact and the paper should not pull free when the hood is closed

The 2 inboard bumpers must have slight clearance to the hood so the paper should pull out but with some drag.



If bumpers and latch are not in adjustment based on the paper test in Step 2, continue with steps 3-5.

If bumpers and latch are in adjustment based on the paper holding its place in Step 2 the procedure is complete. Skip to step 4-5.

3. Raise outboard hood bumpers (2 per side) until hood is flush with fenders, setting the height of the bumpers to 24mm from the bracket surface is a

good starting point. Repeat the paper test in Step 2. If there is not enough contact and hood is flush to the fenders, continue to Steps 4 and 5.

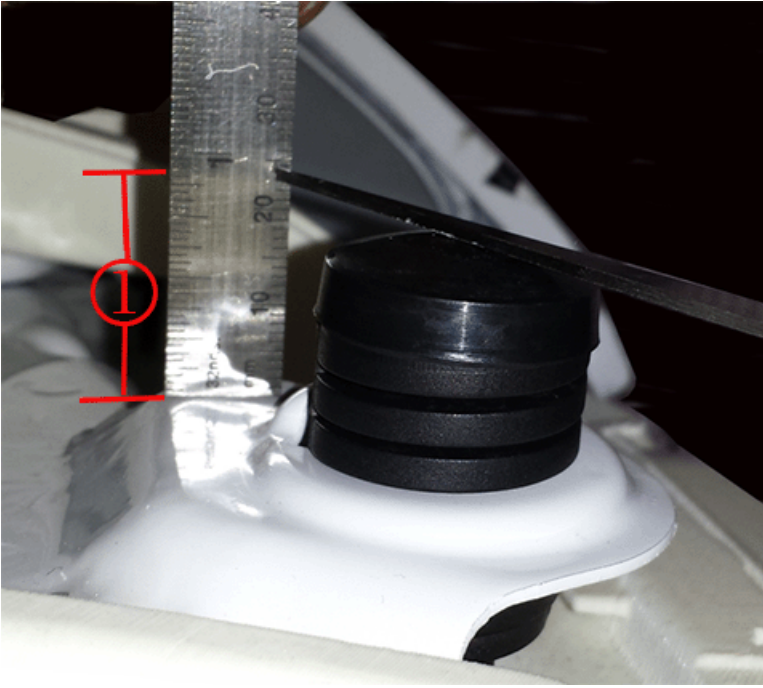

4. Temporarily mark the position of the hood latch. Using a 13mm ratchet or wrench, loosen the hood latch bolts just enough that the latch will move but is not completely free. Lightly tap the hood latch to lower it straight down 1mm (being careful not to move left or right) and retighten to 22Nm (16 lb. ft.) with a torque wrench.
5. Adjust the 2 inboard bumpers to a 23mm height from the bracket surface. Recheck the 2 inboard bumpers with the paper for a light drag, if too tight turn them clockwise 1/4 turn until a light drag is achieved.

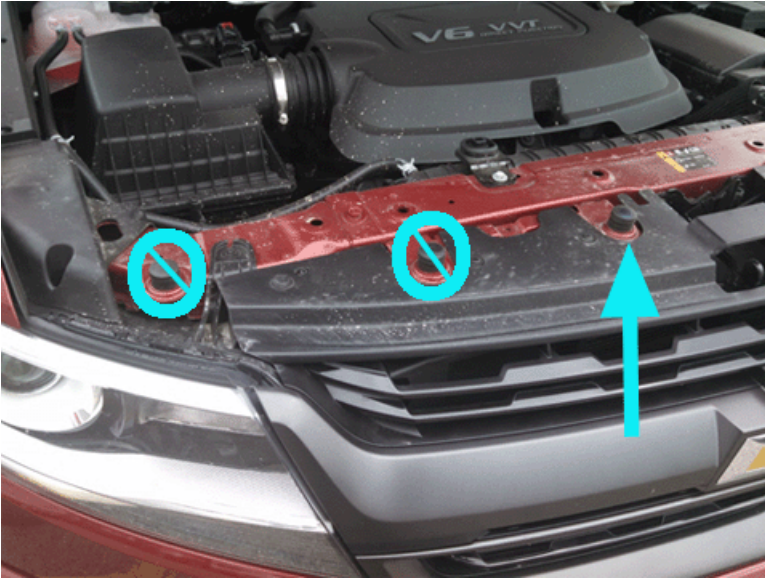

The paper test can be performed on the inner bumpers after latch adjustment. The inner bumpers should have very little to no drag to remove the paper.

Road test the vehicle to verify repair. If concern is a flutter across the rear edge of the hood perform steps 6-9.

6. If applicable, remove the hood insulator.
7. Apply Kent® Ure-Foam Expandable Foam Sound Deadener in two locations (one per side) of the hood as illustrated below.

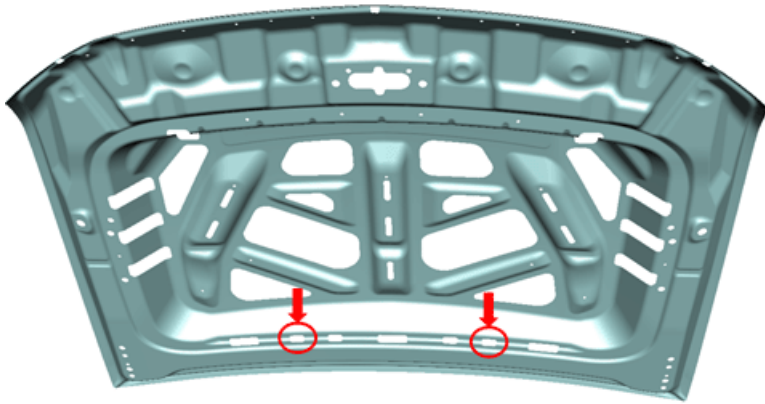

Inject foam into the second hole from the side

Aim the applicator nozzle straight to the back and begin to fill the cavity.

Once half of the product has been dispensed, tilt the tip upward and slowly draw the applicator back as the last half of the foam is injected, ensuring the product is applied to the hood panel.

Remove any excess foam that prevents the hood Insulator from installing into the outer hole

The following illustration (1) shows a cross-sectional slice of the hood assembly. Apply the first half of the product in area (2). Apply the second half of the product in area (3).

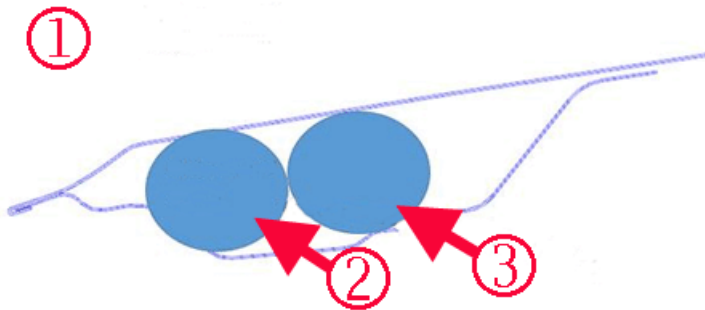

8. Repeat Step 7 on the other side of the hood.
9. Reinstall the Hood Insulator.

Customer Information: Be advised that it can take up to 3 days for the foam used in this repair to fully cure before the maximum benefits are realized. The vehicle can be driven while the foam cures.

Parts Information

Part Number	Description	Qty
*P10630	Kent® Ure-Foam Expandable Foam Sound Deadener	2 per vehicle
*P90378	Kent® Job Size Dual-Cartridge Gun (1 per dealership, this tool will be reused each time a repair is performed.)	1 per dealer

*This is a Kent Automotive Part Number. We believe this source and their products to be reliable. There may be additional manufacturers of such products/materials. General Motors does not endorse, indicate any preference for, or assume any responsibility for the products or material from this firm or for any such items that may be available from other sources.

Warranty Information

For vehicles repaired under warranty use:

Labor Operation	Description	Labor Time
-----------------	-------------	------------

1480538 *	Adjust Hood Bumpers and Latch	0.3 hrs
1480418 *	Apply Expandable Foam To The Hood and Adjust Hood Bumpers and Latch as Needed	0.4 hr
* This is an unique labor operation for bulletin use only. This will not be published in the Labor Time Guide.		

Please follow this diagnostic or repair process thoroughly and complete each step. If the condition exhibited is resolved without completing every step, the remaining steps do not need to be performed.

GM bulletins are intended for use by professional technicians, NOT a "do-it-yourselfer". They are written to inform these technicians of conditions that may occur on some vehicles, or to provide information that could assist in the proper service of a vehicle. Properly trained technicians have the equipment, tools, safety instructions, and know-how to do a job properly and safely. If a condition is described, DO NOT assume that the bulletin applies to your vehicle, or that your vehicle will have that condition. See your GM dealer for information on whether your vehicle may benefit from the information.



WE SUPPORT VOLUNTARY TECHNICIAN CERTIFICATION