



Service Bulletin

PRELIMINARY INFORMATION

Subject: Alleged No Park or Vehicle Rolls in Park or Park Will Not Hold

Models: 2013-2015 Cadillac ATS, CTS Models, Escalade Models
2013 Chevrolet Avalanche
2013-2014 Chevrolet Corvette
2013-2015 Chevrolet Camaro, Express, Silverado, Suburban, Tahoe
2013-2015 GMC Savana, Sierra, Yukon Models
Equipped with 6L45, 6L50, 6L80, 6L90 Automatic Transmission (RPOs MYA, MYB, MYC, MYD)

Attention: This PI also applies to any of the above models that may be Export vehicles.

This PI has been revised to exclude the 2015 Chevrolet Corvette. Please discard PI1360B.

Condition/Concern

Some customers may comment that the vehicle will not hold after the shift lever was placed into the Park position or that the vehicle rolled after the shift lever was placed into the Park position and the brake pedal released.

Important: Customers may also comment that a 4WD full size pickup or utility has a slight movement approximately five seconds after the engine is shut off. This may occur if the vehicle has a transfer case AUTO (Automatic Four-Wheel Drive) setting and the engine is shut off with the transfer case in the AUTO setting. This movement is most likely to occur if the driveline is under a bind, such as if the vehicle were turning when stopped. This is a normal condition, no repairs should be made in an attempt to change this condition.

Recommendation/Instructions

Verify in the Investigate Vehicle History (IVH) to ensure the vehicle has been involved in either of the following bulletins listed below. If the bulletin applies to the vehicle and has not been completed, perform bulletin first before continuing with this PI.

- ⇒ 12331A – Steering Column Lock Actuator Gear
- ⇒ 14192 – Unwanted Transfer Case Shift to Neutral
- ⇒ 14179A – Transmission Shift Cable

If the bulletins listed above have been completed that applies to the vehicle, continue with inspections listed below.

Attempt to duplicate the condition to verify the concern. In some cases it may not be possible to duplicate.

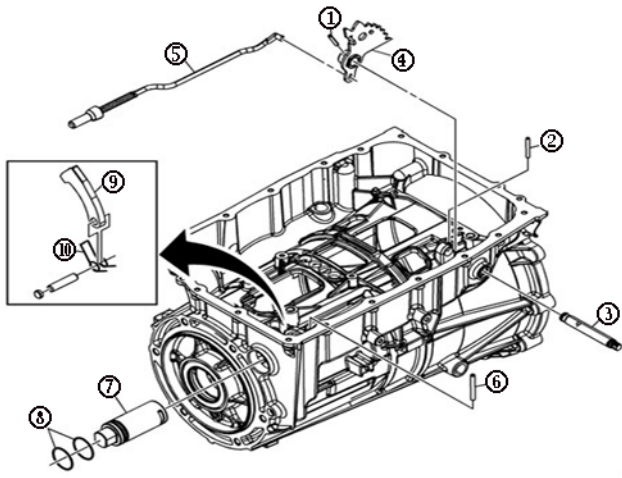

The following inspections listed below may be helpful for diagnoses:

- Inspect the shift cable for proper adjustment and attachment to the range selector lever.
- Remove the transmission oil pan and inspect for debris in the pan or obvious signs of damage.
- Inspect the manual shaft detent lever assembly (4) and park pawl actuator assembly (5) for damage.
- Inspect the park gear for damage or peening of the teeth.
- Inspect the park pawl (9) and park pawl spring (10) for damage.

If no damage was found during the inspection and the cause of the alleged no Park condition was not found, replace the park pawl actuator assembly (5). Refer to the part numbers listed below.

Note: The park pawl (9) and park pawl spring (10) are not serviced separately. If they are found to be damaged, the case assembly must be replaced.

Parts Information

Part Number	Description	Qty
24246412	ACTUATOR, PARK PAWL (RPO MYA)	1
24242086	ACTUATOR, PARK PAWL (RPO MYB)	1
24242085	ACTUATOR, PARK PAWL (RPO MYC)	1
24242088	ACTUATOR, PARK PAWL (RPO MYD)	1

Warranty Information

For vehicles repaired under warranty, use the appropriate labor operation for the repair performed.

GM bulletins are intended for use by professional technicians, NOT a "do-it-yourselfer". They are written to inform these technicians of conditions that may occur on some vehicles, or to provide information that could assist in the proper service of a vehicle. Properly trained technicians have the equipment, tools, safety instructions, and know-how to do a job properly and safely. If a condition is described, DO NOT assume that the bulletin applies to your vehicle, or that your vehicle will have that condition. See your GM dealer for information on whether your vehicle may benefit from the information.



WE SUPPORT VOLUNTARY TECHNICIAN CERTIFICATION