



# Service Bulletin

## TECHNICAL

**Subject:** Clunking Noise from Rear of Vehicle (Re-torque Leaf Spring Bolts)

**Models:** 2007-2013 Chevrolet Silverado  
2014 Chevrolet Silverado 1500  
2014-2015 Chevrolet Silverado 2500/3500  
2015 Chevrolet Colorado  
2007-2013 GMC Sierra  
2014 GMC Sierra 1500  
2014-2015 GMC Sierra 2500/3500  
2015 GMC Canyon

**Attention:** This Bulletin also applies to any of the above models that may be Export vehicles.

*This Bulletin has been revised to add Model Years, Models, update the Correction and update the Labor Operation to the Global Labor Code (GLC). Please discard Corporate Bulletin Number 09-03-09-001A.*

### Condition

Some customers may comment about a clunking noise coming from the rear of the vehicle. Upon further investigation, the technician may diagnose the noise coming from the rear suspension leaf spring area.

### Correction

The noise may be resolved by re-torquing the joints of the leaf spring assembly.

1. Support the vehicle at curb height when re-torquing the leaf spring bolts/nuts.

**Note:** Do not remove the fuel tank.

2. Loosen the shackle joint to the frame, front eye joint to the frame, rear eye to shackle joint and the anchor plate U-bolts.
3. Re-torque the shackle joint to the frame and to the rear eye (1). Refer to SI for torque specifications.

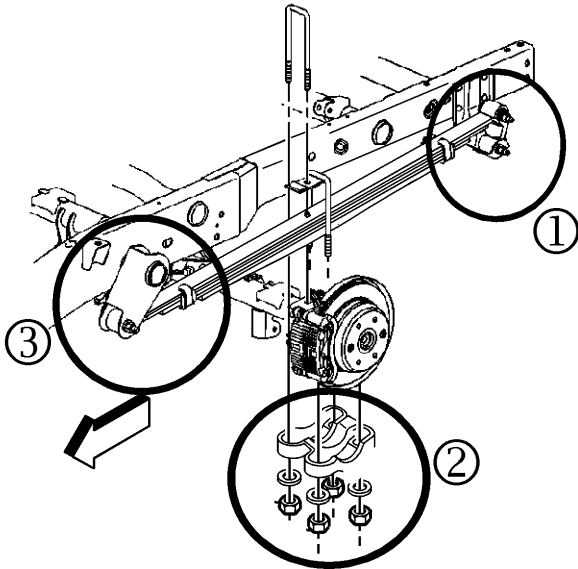

4. Re-torque the anchor plate U-bolts (2). Refer to SI for torque specifications.
5. Re-torque the front rear spring mounting nut (3). Refer to SI for torque specifications.
6. Repeat steps 2 through 5 for the right side leaf spring.
7. Re-test the vehicle for the same clunking noise. If the issue remains, follow the regular repair procedure.

## Warranty Information

For vehicles repaired under warranty, use:

Labor Operation	Description	Labor Time
8080128*	Retorque Bolts/ Road Test	0.8 hr
*This is a unique Labor Operation for Bulletin use only. It will not be published in the Labor Time Guide.		

GM bulletins are intended for use by professional technicians, NOT a "do-it-yourselfer". They are written to inform these technicians of conditions that may occur on some vehicles, or to provide information that could assist in the proper service of a vehicle. Properly trained technicians have the equipment, tools, safety instructions, and know-how to do a job properly and safely. If a condition is described, DO NOT assume that the bulletin applies to your vehicle, or that your vehicle will have that condition. See your GM dealer for information on whether your vehicle may benefit from the information.



WE SUPPORT VOLUNTARY TECHNICIAN CERTIFICATION