



Service Bulletin

PRELIMINARY INFORMATION

Subject: Diagnostic Tip for DTC P305F

Models: 2014-2015 Chevrolet Malibu
Equipped with Start/Stop System (RPO KL9)

Condition/Concern

Technicians may find the diagnostic trouble code (DTC) P305F: Dual Battery Control Module Performance has been set in the Engine Control Module (ECM). There may be several different causes of this code setting and before any component replacements, please follow the recommendations below.

Recommendation/Instructions

Important: Do NOT replace the ECM for this DTC.

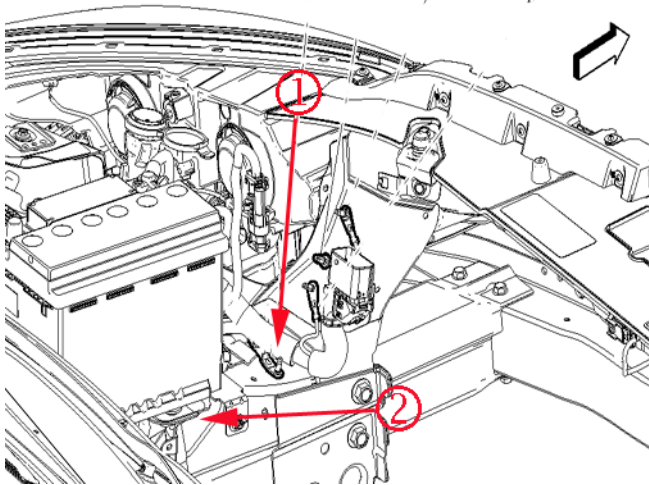

Inspect the Following:

- Inspect for loose unsecured electrical ground at G103 (1).
- Verify the engine harness is not pinched underneath the main battery tray (2).
- Inspect both main and auxiliary battery cables for being secured.
- Perform the battery inspection/test in SI (Document ID# 3469663) to the auxiliary battery.

Warranty Information

For vehicles repaired under warranty, use the appropriate labor operation for the repair performed.

GM bulletins are intended for use by professional technicians, NOT a "do-it-yourselfer". They are written to inform these technicians of conditions that may occur on some vehicles, or to provide information that could assist in the proper service of a vehicle. Properly trained technicians have the equipment, tools, safety instructions, and know-how to do a job properly and safely. If a condition is described, DO NOT assume that the bulletin applies to your vehicle, or that your vehicle will have that condition. See your GM dealer for information on whether your vehicle may benefit from the information.



WE SUPPORT VOLUNTARY TECHNICIAN CERTIFICATION