



INSTRUCTION TO SERVICE

ITS: 5907

SECTION:	231 Coolant System
WRITTEN BY:	Mike Pearson
SUBJECT:	Add Low Floor EMP Radiator Ground Straps

ITS5907

THIS DOCUMENT AND THE CONTENTS DISCUSSED HEREIN ARE THE CONFIDENTIAL AND PROPRIETARY INFORMATION OF NEW FLYER INDUSTRIES CANADA ULC AND NEW FLYER OF AMERICA INC. AND ARE DISCLOSED BY NEW FLYER IN CONFIDENCE. THIS DOCUMENT AND THE CONTENTS HEREIN ARE NOT TO BE DISCLOSED BY THE INTENDED RECIPIENT WITHOUT THE PRIOR WRITTEN AUTHORIZATION OF NEW FLYER. ANY UNAUTHOIZED DISCLOSURE, REPRODUCTION OR OTHER DISTRIBUTION OF THIS DOCUMENT OR INFORMATION IS STRICTLY PROHIBITED AND MAY RESULT IN ACTION BEING TAKEN AGAINST THE PARTY MAKING THE UNAUTHORIZED DISCLOSURE. THIS DOCUMENT AND ALL COPIES HEREOF MUST BE RETURNED TO NEW FLYER UPON REQUEST.



NEW FLYER

Bulletin Overview

If dissimilar metals have different electrode potentials, and come into contact with an electrolyte, one metal acts as an anode and the other as cathode. The electro potential difference between the dissimilar metals and the presence of electrolytic (salt) solutions can be the driving force for an accelerated attack on the anode member of the galvanic couple. The anode metal dissolves into the electrolyte, and deposits collect on the cathodic metal.

In normal service, voltage levels on coolant pipes have been found to be highly variable and can range anywhere from roughly -1V to +1V.

These voltage levels are capable of causing highly-accelerated heat exchanger corrosion.

Voltage potential between radiator and coolant pipes can be eliminated by grounding the Mini-Hybrid® cooling system and coolant pipes to the vehicle chassis.

Note: If experiencing accelerated radiator corrosion, the work described in this bulletin must be completed in order to maintain your 3 year EMP radiator warranty coverage. Failure to act promptly may affect coverage for accelerated corrosion through the radiator due to stray current.

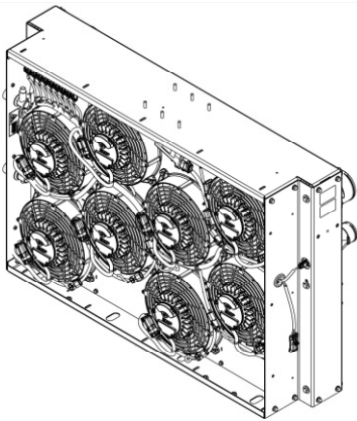

MH8 5034G FiL - TMC

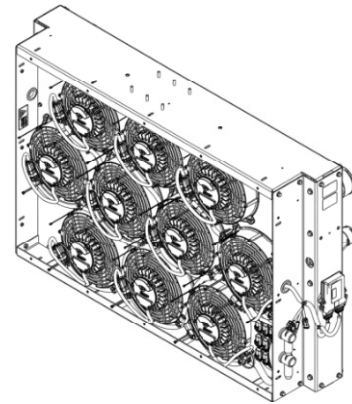

MH10 - 5536

Figure 1: Mini-Hybrid® Cooling Systems

Issue

Radiator corrosion has been identified on buses with isolated pipe clamps on vehicles 2010 EPA or newer engines and Mini-Hybrid® cooling systems including:

Description	New Flyer p/n	EMP Base #
MH8 5034G FiL-TMC	420350	2020035069
MH10-5536	397304	2020044014PA01

Accelerated corrosion was located by the radiator outlet and was limited to vehicles running in icy or snowy winter locations. This corrosion has been determined to be caused by stray voltage carried by the coolant. If the pipes are separated from the radiator via silicone (non-conducting) hoses and the pipes and radiator are not on the same ground plane, electrolysis can occur between the pipes and the radiator. Grounding the radiator and pipes to the vehicle chassis eliminates the electrical potential, stopping the electrolytic corrosion. See Figure 2 for images of accelerated corrosion.



NEW FLYER



Figure 2: Gen II Examples.

PROCEDURE:

1. Turn the main battery disconnect switch to the "OFF" position.
2. Raise coach in accordance with the New Flyer Service Manual.
3. Typical coolant tube clamp ground strap mounting hardware orientation, see Figure 3.



Figure 3: Ground Strap Mounting Hardware Orientation

4. Drill a 0.281 dia clearance hole thru the rear corner support angle at the dimensions shown in Figure 4 and 5.
5. Grind a circular area approximately 1" diameter around the newly drilled 0.281 diameter hole removing the powder/paint off the vertical support from the rear structural angle. See Figure 4.

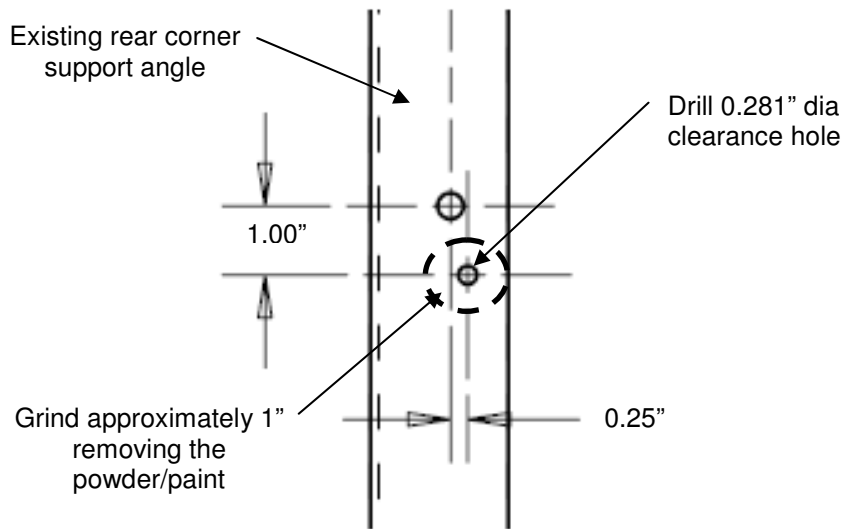

Figure 4: Existing Rear Corner Support Angle

6. Insert $\frac{1}{4}$ "-20unc x $\frac{3}{4}$ " hex head flange screw thru the rear of the angle so that it forms a stud to attach the ring terminals. Place the $\frac{1}{4}$ " ring tongue terminal end of the 12" and 24" cable assemblies on the stud, then a $\frac{1}{4}$ " washer and the $\frac{1}{4}$ " locknut. Routing the wires away from any hot surfaces or sharp edges. Torque to 12 ± 2 ft*lbs.
7. Secure the loose end of the 12" cable assembly installed in Step 6 to the shroud using a $\frac{5}{16}$ " hex flange head screw. Torque to 25 ± 4 ft*lbs.
8. Install one of the 2.5" guillotine clamp to the existing upper radiator tube at the approximate location and orientation shown in Figure 5, torque to 20 ± 2 . Attach the loose end of the 24" cable assembly installed in Step 6 to the rear stud of the clamp using a $\frac{3}{8}$ " washer (x2), the cable ring tongue and $\frac{3}{8}$ " locknut. Secure the hardware to the clamp in the orientation shown in Figure 3. Torque clamp to 20 ± 2 ft*lbs.
9. Apply Primer or a protective coating over any bare metal including cable ends and their mounting hardware.

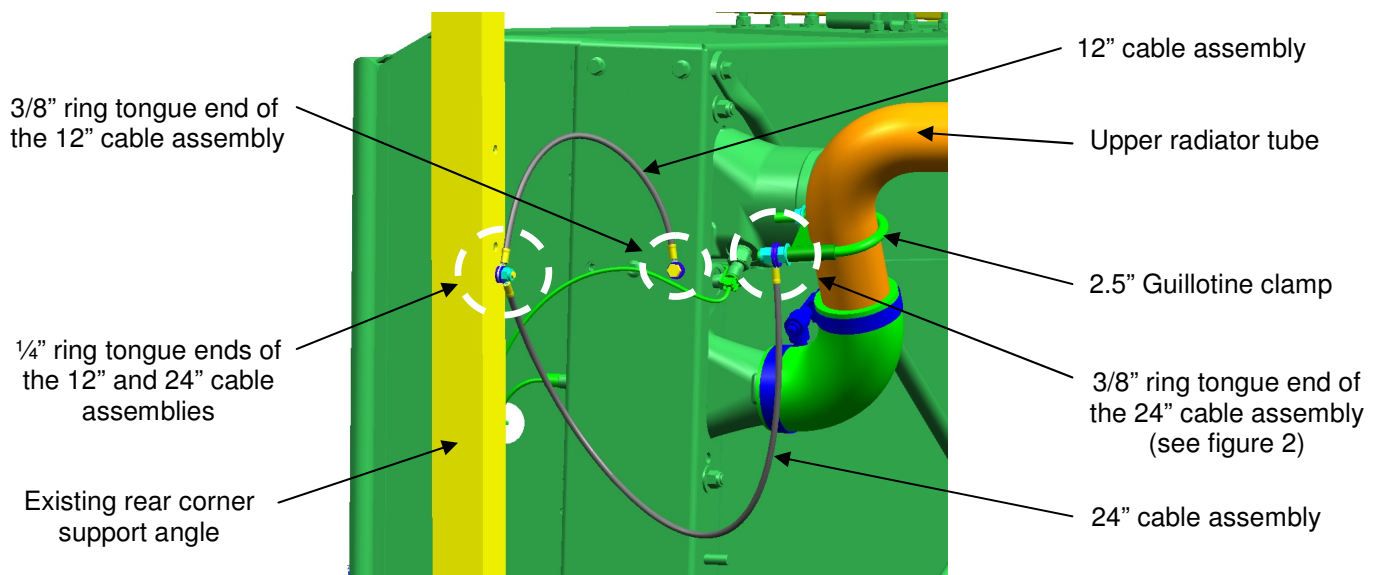

Figure 5: Radiator and Upper Coolant Tube Ground Strap Installation



NEW FLYER

10. Grind a circular area approximately 1" diameter around the existing clearance hole in the rear bulkhead panel as shown in figures 5 and 6 removing the powder/paint off the panel.
11. Insert 1/4"-20unc x 3/4 hex head flange screw thru the rear bulkhead panel hole from Step 10 so that it forms a stud to attach the ring terminal. Place a 1/4" washer on the stud followed by the 3/8" ring tongue terminal end of a 12" cable assembly, a second 1/4" washer and the 1/4" locknut. Routing the wire away from any hot surfaces or sharp edges. Torque to 12 ± 2 ft*lbs.
12. Install the remaining 2.5" guillotine clamp to the existing lower radiator tube at the approximate location and orientation shown in Figure 6, Torque to 20 ± 2 . Attach the loose end of the 12" cable assembly installed in Step 11 to the curbside stud of the clamp using a 3/8" washer (x2), and 3/8" locknut. Secure the hardware to the clamp in the orientation shown in Figure 6. Torque clamp to 20 ± 2 ft*lbs.

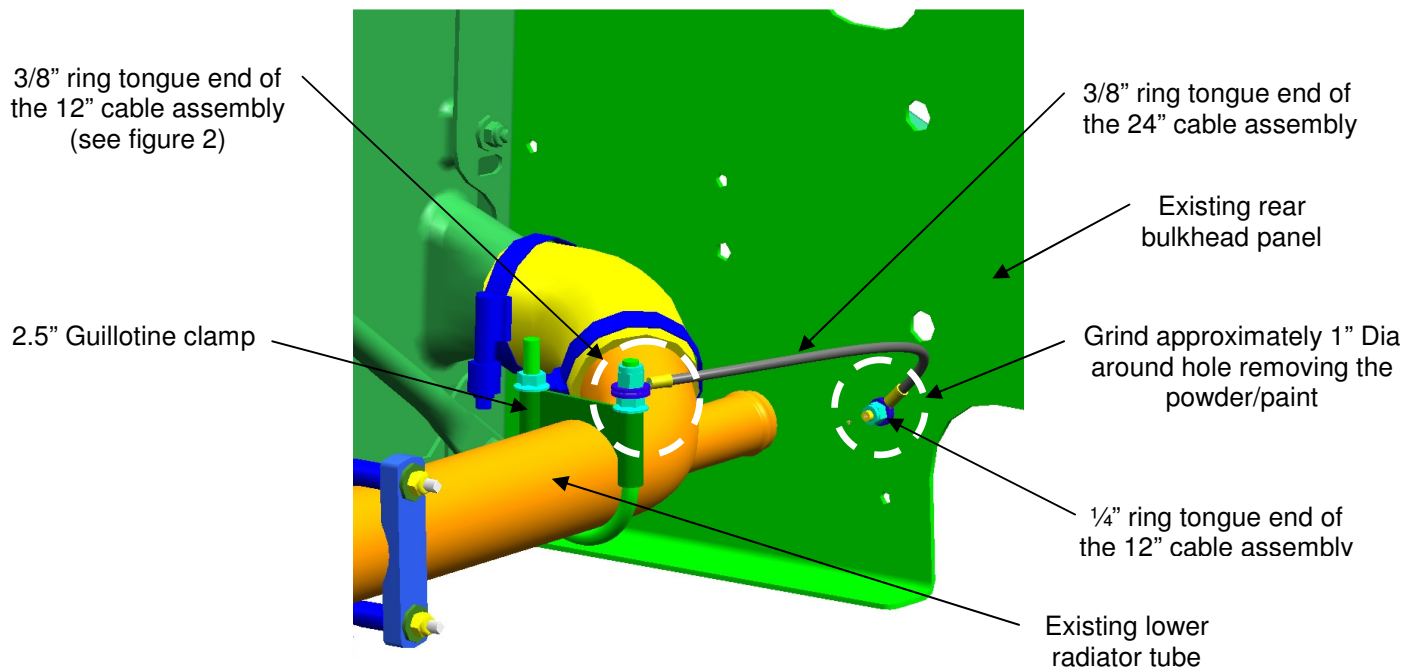

Figure 6: Lower Coolant Tube Ground Strap

13. Apply primer or a protective coating over any bare metal including cable ends and their mounting hardware.
14. If necessary, lower coach in accordance with the New Flyer Service Manual.
15. Turn the main battery disconnect switch to the "ON" position.



NEW FLYER

LABOUR ESTIMATE

	Operation	Men	Hours	Labour Time M X HR
1	Add Low Floor EMP Radiator Ground Straps	1	0.5	0.5

PARTS REQUIRED

Item	Part Number	Description	Qty. per Coach	Units	Notes
1	6449007	Kit-EMP Radiator Ground Strap Rework	1	EA	Vpn 1370044044