



## INSTRUCTION TO SERVICE

<b>ITS: 5964</b>	
<b>SECTION:</b>	292 Electrical Harnesses
<b>WRITTEN BY:</b>	Ken Chubaty
<b>SUBJECT:</b>	Front Height Sensor Rewiring with Shielded Cable

# ITS5964

THIS DOCUMENT AND THE CONTENTS DISCUSSED HEREIN ARE THE CONFIDENTIAL AND PROPRIETARY INFORMATION OF NEW FLYER INDUSTRIES CANADA ULC AND NEW FLYER OF AMERICA INC. AND ARE DISCLOSED BY NEW FLYER IN CONFIDENCE. THIS DOCUMENT AND THE CONTENTS HEREIN ARE NOT TO BE DISCLOSED BY THE INTENDED RECIPIENT WITHOUT THE PRIOR WRITTEN AUTHORIZATION OF NEW FLYER. ANY UNAUTHOIZED DISCLOSURE, REPRODUCTION OR OTHER DISTRIBUTION OF THIS DOCUMENT OR INFORMATION IS STRICTLY PROHIBITED AND MAY RESULT IN ACTION BEING TAKEN AGAINST THE PARTY MAKING THE UNAUTHORIZED DISCLOSURE. THIS DOCUMENT AND ALL COPIES HEREOF MUST BE RETURNED TO NEW FLYER UPON REQUEST.

**PROCEDURE:**

1. Turn the main battery disconnect switch to the “OFF” position.
2. If necessary, raise coach in accordance with the New Flyer Service Manual.
3. From inside the coach, raise the side console.
4. From outside the coach, open the side console access door.
5. Locate wires 55LK54D, 55LK54F, and 55AF85B at XSC71-TWR.
6. Cut wire 55LK54D and 55LK54F (3 inches away from the connector), but carefully remove 55AF85B from the connector.
7. Discard the connector.
8. Cap the 55LK54D and 55LK54F wires with the supplied vinyl end caps (PN 8111673).
9. Locate wire 55LK54J at the ground bar under the side console.
10. Remove the wire from the ground bar and cut off the terminal. Cap the wire with the supplied vinyl end cap (PN 8111673).
11. Locate the front height sensor inside the street side wheel well (see figure 1 for location).
12. Remove the connector from the sensor and cut off the connector.
13. Cap the three wires with the supplied vinyl end cap (PN 8111673).

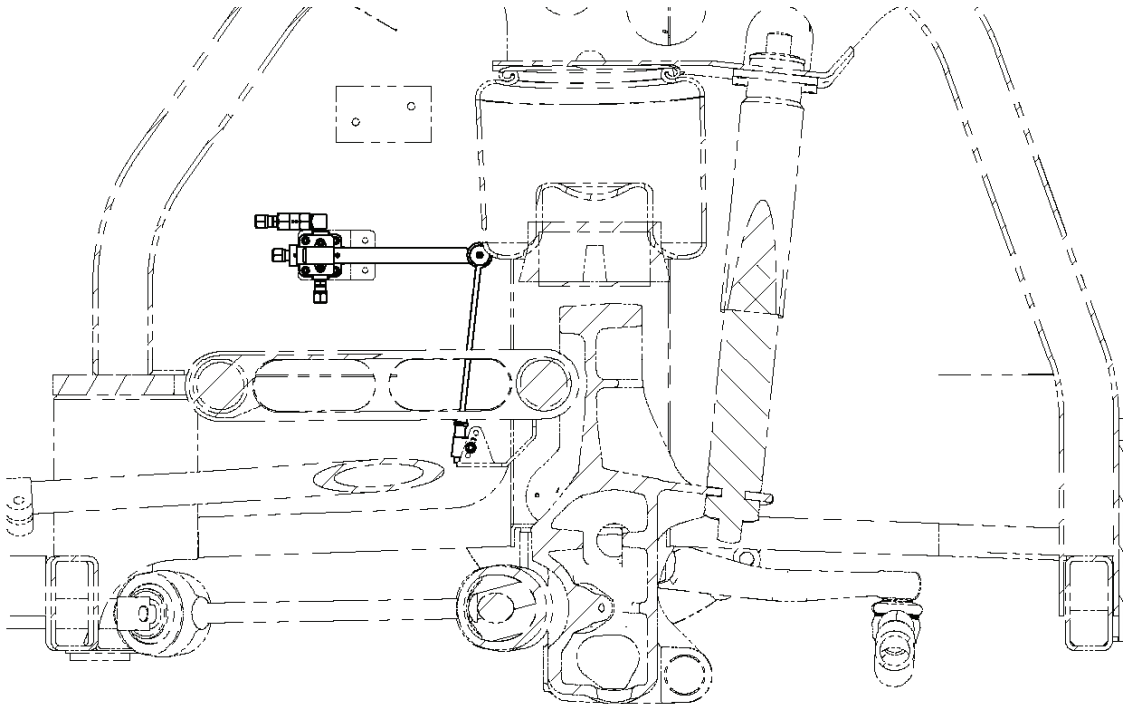
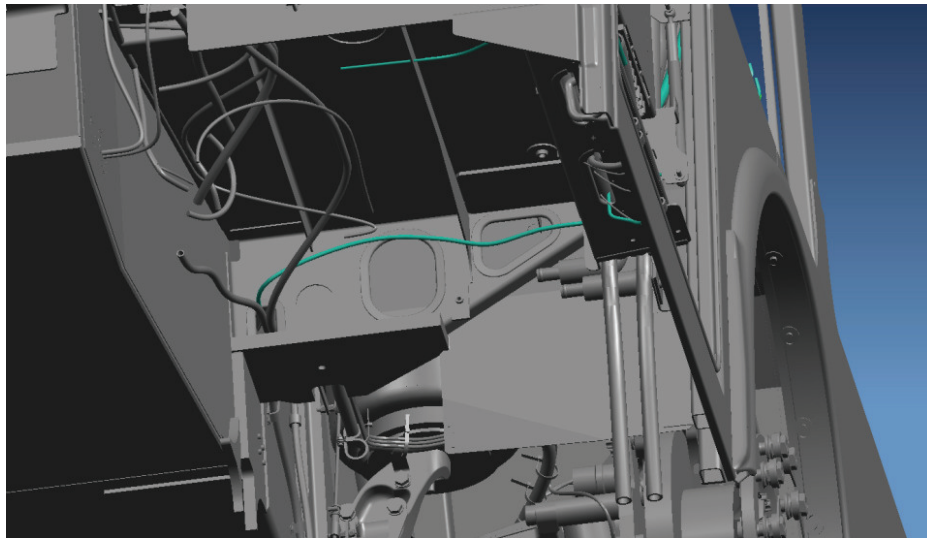
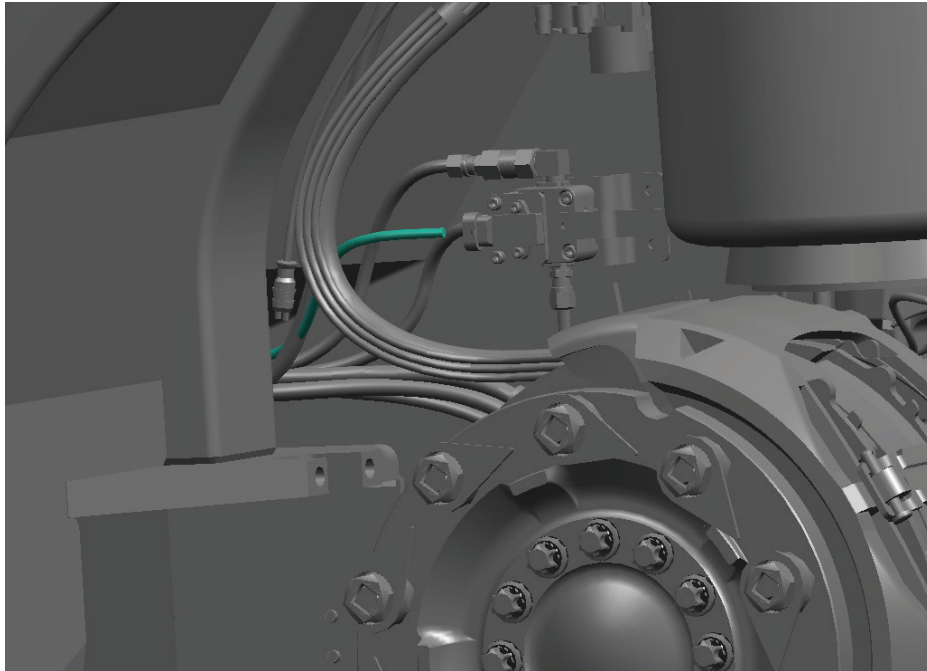

**Figure 1: Front Height Sensor Location**



## NEW FLYER

14. Using the supplied harness (PN 584601), route the harness as per figures 2 and 3. The cable will route from XSC71 (bottom side of the side console) and will split towards the front height sensor and the ground bar under the side console. Secure the harness with the supplied tyraps (PN 5hor963577) every 8 inches.
15. Connect the Front Height Sensor connector to the sensor once routed.

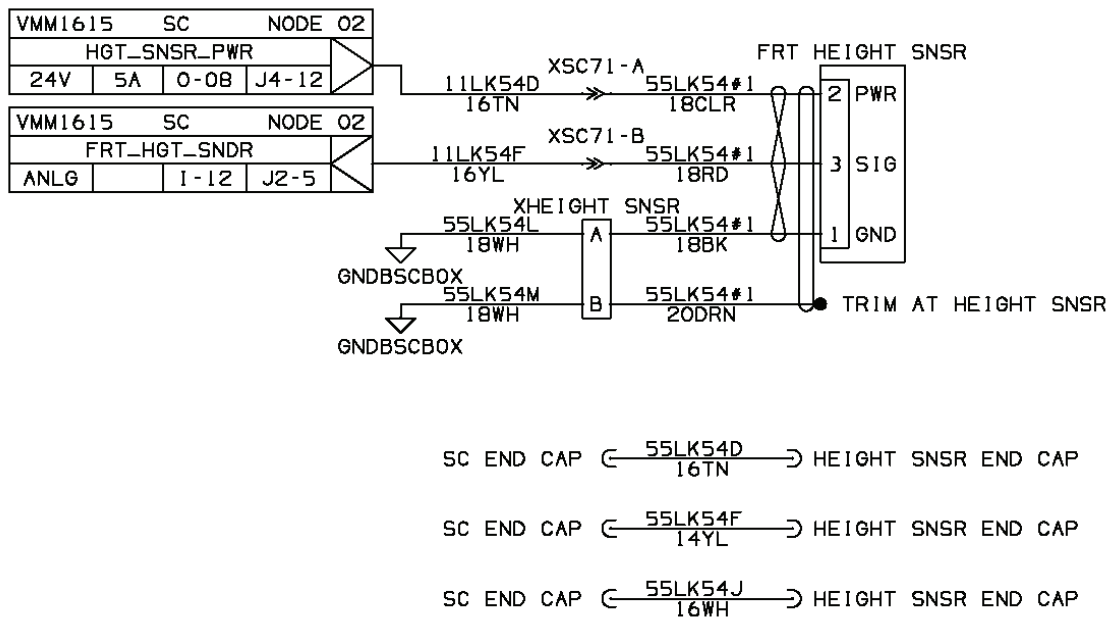

**Figure 2: Front Height Sensor Cable Routing**



**Figure 3: Front Height Sensor Cable Routing**

16. At the XSC71 location, locate wire 55AF85B that was pulled out earlier and install it into cavity C of the XSC71 connector of the new harness.
17. Connect the XSC71 connector to the side console.
18. Route the GNDBSCBOX section of the cable towards the ground bar under the side console.
19. Before installing the two white wires onto the ground bar, clean off the dielectric grease from the intended location.
20. Install the two wires onto the ground bar. Torque screws to 40 in-lbs (dry).
21. Apply dielectric grease to the new ground wires.
22. If necessary, lower coach in accordance with the New Flyer Service Manual.
23. Turn the main battery disconnect switch to the "ON" position.
24. Test the kneeling function to ensure the front height sensor and the kneeling system is operating correctly.



**Figure 4: Front Height Sensor Schematic**



**NEW FLYER**

### LABOUR ESTIMATE

	Operation	Men	Hours	Labour Time M X HR
1	Front Height Sensor Rewiring with Shielded Cable	1.0	1.5	1.5

### PARTS REQUIRED

Item	Part Number	Description	Qty. per Coach	Units	Notes
1	584601	HRNS-FRT HEIGHT SNSR JMPR	1	EA	
2	5963577	TYRAP-STD 15" BLACK	20	EA	
3	8111673	END CAP .137BK-14SXL	6	EA	
4	8111767	LUBRICANT NYK-77	0.01	EA	Source Locally