



# Service Bulletin

American Honda Motor Co., Inc.

## SAFETY RECALL

### MULTIPLE MODELS - STARTER RELAY SWITCH INSPECTION/REPLACEMENT

Honda Motor Co., Ltd is conducting a Safety Recall of motorcycles and scooters listed in the **AFFECTED UNITS** section of this bulletin. Honda has determined that a defect within certain starter relay switch assemblies can cause an increase in resistance across the main fuse, potentially interrupting battery voltage to the electrical system which can cause the engine to A) not start or B) stall while riding. In an extreme case, the increased resistance at the main fuse can cause the starter relay switch to catch on fire.

A replacement starter relay switch is available to correct this condition in units that fail the inspection procedure.

**Safety Consequence**

An engine that stalls while riding increases the risk of a crash.

### CUSTOMER NOTIFICATION

American Honda is sending a letter to owners of all affected motorcycles, informing them that their motorcycle/scooter is being recalled for a safety related defect. The customer will be made aware of the safety risk and advised to have a Honda dealer inspect and, if necessary, replace the starter relay switch.

For your reference, a copy of the Customer Letter is reproduced on pages 10 and 11 of this Service Bulletin.

### AFFECTED UNITS

Model	Model Year	Type	VIN Range
CRF250L	2014	AC	MLHMD381*E5102773 thru MLHMD381*E5107622
	2015	AC	MLHMD381*F5200001 thru MLHMD381*F5202950
CB300F	2015	AC	MLHNC521*F5100001 thru MLHNC521*F5102642
CBR300R	2015	A, 2A, 8A	MLHNC510*F5100225 thru MLHNC510*F5103186
		AC, 3AC, 9AC	MLHNC511*F5100023 thru MLHNC511*F5100666
CBR300RA	2015	AC, 3AC, 9AC	MLHNC515*F5100033 thru MLHNC515*F5101026
NSS300	2014	AC	MLHNF040*E5001971 thru MLHNF040*E5001990
	2015	AC	MLHNF040*F5100001 thru MLHNF040*F5100426

\* Denotes check digit.

**CUSTOMER INFORMATION:** The information in this bulletin is intended for use only by skilled technicians who have the proper tools, equipment, and training to correctly and safely maintain your Honda. These procedures should not be attempted by "do-it yourselfers," and you should not assume this bulletin applies to your Honda, or that your Honda has the condition described. To determine whether this information applies, contact an authorized Honda dealer.

**MULTI-MODEL: STARTER RELAY SWITCH #1**  
**JULY 2015**

Model	Model Year	Type	VIN Range	
<b>NSS300A</b>	2014	AC	MLHNF041*E5000335 thru	MLHNF041*E5000346
	2015	AC	MLHNF041*F5100001 thru	MLHNF041*F5100278
<b>CB500F</b>	2014	A, 3A	MLHPC456*E5101299 thru	MLHPC456*E5101374
		AC, 2AC	MLHPC451*E5100237 thru	MLHPC451*E5100258
	2015	3A	MLHPC456*F5200001 thru	MLHPC456*F5200924
		2AC	MLHPC451*F5200001 thru	MLHPC451*F5200170
<b>CB500FA</b>	2014	AC	MLHPC450*E5100287 thru	MLHPC450*E5100308
	2015	2AC	MLHPC450*F5200001 thru	MLHPC450*F5200296
<b>CB500X</b>	2014	A	MLHPC466*E5100767 thru	MLHPC466*E5100884
		AC	MLHPC461*E5100143 thru	MLHPC461*E5100166
	2015	A	MLHPC466*F5200001 thru	MLHPC466*F5200656
		AC	MLHPC461*F5200001 thru	MLHPC461*F5200132
<b>CB500XA</b>	2014	AC	MLHPC460*E5100103 thru	MLHPC460*E5100164
	2015	AC	MLHPC460*F5200001 thru	MLHPC460*F5200226
<b>CBR500R</b>	2014	A, 3A	MLHPC446*E5101899 thru	MLHPC446*E5102384
		AC, 2AC	MLHPC441*E5100347 thru	MLHPC441*E5100446
	2015	A	MLHPC446*F5200001 thru	MLHPC446*F5201626
		AC	MLHPC441*F5200001 thru	MLHPC441*F5200339
<b>CBR500RA</b>	2014	AC	MLHPC440*E5100399 thru	MLHPC440*E5100544
	2015	AC	MLHPC440*F5200001 thru	MLHPC440*F5200367
<b>CBR600RR</b>	2015	A	JH2PC400*FK800001 thru	JH2PC400*FK801445
		AC	JH2PC401*FK800001 thru	JH2PC401*FK800287
<b>CBR600RA</b>	2015	AC	JH2PC408*FK800001 thru	JH2PC408*FK800070
<b>CBR650F</b>	2014	A	MLHRC740*E5000001 thru	MLHRC740*E5001482
		AC	MLHRC741*E5000001 thru	MLHRC741*E5000271
	2015	A	MLHRC740*F5100001 thru	MLHRC740*F5100696
		AC	MLHRC741*F5100001 thru	MLHRC741*F5100144
<b>CBR650FA</b>	2014	AC	MLHRC745*E5000002 thru	MLHRC745*E5000268
	2015	AC	MLHRC745*F5100001 thru	MLHRC745*F5100112
<b>CTX700</b>	2014	A	JH2RC690*EK001401 thru	JH2RC690*EK001459
		AC	JH2RC691*EK000145 thru	JH2RC691*EK000150
	2015	A	JH2RC690*FK100001 thru	JH2RC690*FK100348
		AC	JH2RC691*FK100001 thru	JH2RC691*FK100060
<b>CTX700D</b>	2014	A	JH2RC694*EK000829 thru	JH2RC694*EK001011
		AC	JH2RC695*EK000096 thru	JH2RC695*EK000147
	2015	A	JH2RC694*FK100001 thru	JH2RC694*FK100893
		AC	JH2RC695*FK100001 thru	JH2RC695*FK100149
<b>CTX700N</b>	2015	A	JH2RC680*FK100001 thru	JH2RC680*FK100418
		AC	JH2RC681*FK100001 thru	JH2RC681*FK100062
<b>CTX700ND</b>	2015	A	JH2RC684*FK100001 thru	JH2RC684*FK100888
		AC	JH2RC685*FK100001 thru	JH2RC685*FK100134

\* Denotes check digit.

**MULTI-MODEL: STARTER RELAY SWITCH #1  
JULY 2015**

Model	Model Year	Type	VIN Range
<b>NC700X</b>	2014	A	JH2RC630*EK000001 thru JH2RC630*EK001394
		AC	JH2RC635*EK200001 thru JH2RC635*EK200246
	2015	A	JH2RC630*FK100001 thru JH2RC630*FK100957
		AC	JH2RC635*FK300001 thru JH2RC635*FK300166
<b>NC700XD</b>	2014	A	JH2RC634*EK000001 thru JH2RC634*EK000350
		AC	JH2RC631*EK200002 thru JH2RC631*EK200061
	2015	A	JH2RC634*FK100001 thru JH2RC634*FK100469
		AC	JH2RC631*FK300001 thru JH2RC631*FK300109
<b>NC700JD</b>	2015	AC	JH2RC811*FK000001 thru JH2RC811*FK000207
	2016	AC	JH2RC811*GK100001 thru JH2RC811*GK100174
<b>VT750C</b>	2014	A	JH2RC500*EK100004 thru JH2RC500*EK100471
		AC	JH2RC501*EK100001 thru JH2RC501*EK100053
	2015	A	JH2RC500*FK200001 thru JH2RC500*FK201363
		AC	JH2RC501*FK200001 thru JH2RC501*FK200146
<b>VT750CA</b>	2014	A	JH2RC504*EK900001 thru JH2RC504*EK900313
		AC	JH2RC505*EK900001 thru JH2RC505*EK900036
<b>VT750CS</b>	2014	AC	JH2RC508*EK300001 thru JH2RC508*EK300027
	2015	AC	JH2RC508*FK400001 thru JH2RC508*FK400041
<b>VT750C2</b>	2014	A	JH2RC530*EK600004 thru JH2RC530*EK600381
		AC	JH2RC531*EK600001 thru JH2RC531*EK600039
<b>VT750C2B</b>	2014	A	JH2RC537*EK400004 thru JH2RC537*EK400845
		AC	JH2RC538*EK400001 thru JH2RC538*EK400105
	2015	A	JH2RC537*FK500001 thru JH2RC537*FK502563
		AC	JH2RC538*FK500001 thru JH2RC538*FK500337
<b>VT750C2F</b>	2014	A	JH2RC534*EK700001 thru JH2RC534*EK700282
		AC	JH2RC535*EK700001 thru JH2RC535*EK700029
<b>VT750C2S</b>	2014	AC	JH2RC53G*EK200001 thru JH2RC53G*EK200019
<b>ST1300PA</b>	2013	AC	JH2SC515*DK100048 thru JH2SC515*DK100106
	2014	AC	JH2SC515*EK200003 thru JH2SC515*EK200141
	2015	AC	JH2SC515*FK300001 thru JH2SC515*FK300181
<b>VT1300CX</b>	2014	3A	JH2SC61N*EK200004 thru JH2SC61N*EK200647
		AC	JH2SC611*EK400001 thru JH2SC611*EK400035
	2015	3A	JH2SC61N*FK300001 thru JH2SC61N*FK300319
		4A	JH2SC61P*FK100001 thru JH2SC61P*FK100416
		5AC	JH2SC61V*FK100001 thru JH2SC61V*FK100036
		AC	JH2SC611*FK500001 thru JH2SC611*FK500213
<b>VT1300CXA</b>	2014	AC	JH2SC618*EK300001 thru JH2SC618*EK300018
	2015	2AC	JH2SC618*FK400001 thru JH2SC618*FK400018

\* Denotes check digit.

**MULTI-MODEL: STARTER RELAY SWITCH #1  
JULY 2015**

Model	Model Year	Type	VIN Range	
VT1300CR	2014	A	JH2SC660*EK400004 thru	JH2SC660*EK400233
		AC	JH2SC661*EK400001 thru	JH2SC661*EK400011
	2015	A	JH2SC660*FK500001 thru	JH2SC660*FK500838
		AC	JH2SC661*FK500001 thru	JH2SC661*FK500044
VT1300CRA	2014	AC	JH2SC665*EK200001 thru	JH2SC665*EK200007
	2015	AC	JH2SC665*FK300001 thru	JH2SC665*FK300018
VT1300CT	2014	A	JH2SC667*EK400004 thru	JH2SC667*EK400465
		AC	JH2SC668*EK400001 thru	JH2SC668*EK400025
	2015	A	JH2SC667*FK500001 thru	JH2SC667*FK500826
		AC	JH2SC668*FK500001 thru	JH2SC668*FK500057
VT1300CTA	2014	AC	JH2SC66J*EK300001 thru	JH2SC66J*EK300015
	2015	AC	JH2SC66J*FK400001 thru	JH2SC66J*FK400017

\* Denotes check digit.

**DEALER INVENTORY**

**Do not sell any un-repaired units.**

According to federal law, any affected units in your new inventory cannot be sold or leased until they are inspected or repaired with a replacement starter relay switch, and Honda policy prohibits the sale of new or used un-repaired units. To identify affected units in your inventory, refer to *Unit Information* and your *eResponsibility Report* on **iN**. Then proceed with the **REPAIR VERIFICATION** section of this Service Bulletin.

**REPAIR VERIFICATION**

Before you begin the Inspection Procedure, check if the inspection/repair has been performed on the unit. Some units within the affected VIN range may have been factory-repaired. See the **IDENTIFICATION** section of this Service Bulletin for punch mark locations.

- If there is a punch mark:
  - No further action is necessary
- If there is no punch mark:
  - You must proceed with the **INSPECTION PROCEDURE** section of this Service Bulletin.

**INSPECTION PROCEDURE**

**Service Manual**

To complete the Inspection Procedure use the model specific Service Manual. Service Manuals are also available on **iN** HISP by following the path below and typing in the VIN or selecting the model and year, and selecting *Service Manual* from the *Select Subject* drop down list.

**SERVICE > Service Publications > HISP**

**Inspection Procedure**

1. Refer to the BATTERY/CHARGING SYSTEM section of the Service Manual and disconnect the battery negative (-) cable.
2. Refer to the ELECTRIC STARTER section of the Service Manual and locate the starter relay switch.
3. Inspect the four character lot number on the underside of the starter relay switch as shown and record it on the R/O.

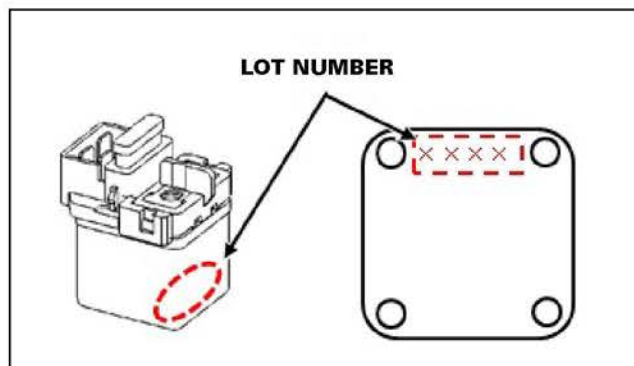

4. Determine if the lot number is within the range of NO GOOD starter relay switches by comparing the lot number to the information below:

**Reading the Lot Number**

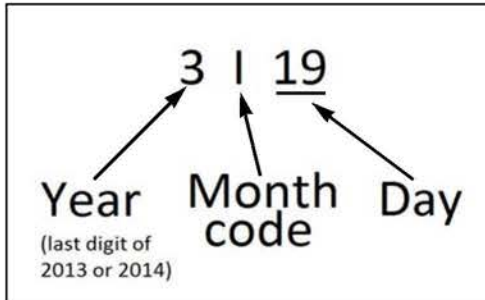

**Decoding the Lot Number**

for Example:  
 Lot No. 3I19 ⇒ Year: 2013, Month: September, Day: 19

3	I	19							
↑	↑	↑							
		Day							
			Month						
			Month:	Jan	Feb	Mar	Apr	May	Jun
				A	B	C	D	E	F
				Jul	Aug	Sep	Oct	Nov	Dec
				G	H	I	J	K	L

Year  
 Notice: the last digit of the year.

**NO GOOD Lot Numbers**

**3I19 through 4I01**

(Parts manufactured from September 19, 2013 through September 1, 2014)

Any lot number within the NO GOOD range is potentially defective and must be replaced. Any lot number outside that range is OK.

- If the starter relay switch is OK:
  - Reinstall the relay switch and then connect the battery negative (-) cable.
  - Proceed to the **IDENTIFICATION** section of this bulletin, follow the instructions for the model at hand and apply the punch mark to the unit.
  - File a warranty claim using the chart in the **CLAIM and PARTS INFORMATION** section of this bulletin.
- If the starter relay switch is NO GOOD:
  - Proceed to the **REPAIR PROCEDURE** section of this bulletin.

**REPAIR PROCEDURE**

Proceed with this section only after determining that the starter relay switch requires replacement, as shown in the **INSPECTION PROCEDURE**.

1. Refer to the **CLAIM and PARTS INFORMATION** section of this bulletin to find the correct replacement part number for the model being repaired.
2. Refer to the **ELECTRIC STARTER** section of the Service Manual and remove the starter relay switch.
3. Carefully inspect the starter relay switch 4P (Red) connector (wire harness side) for any damage (melted, burned).



- If the connector is damaged, call Tech-Line for further instructions.
  - If the connector is OK, proceed to Step 4.
4. Replace the starter relay switch with the new part.  
 Make sure the 30 A (Green) fuse is installed in the top of the relay switch assembly. *Do not use the 20 A or 15 A fuses supplied in the repair parts kit.*
  5. Reconnect the battery negative (-) cable.
  6. Confirm the repair by turning the ignition switch to ON and starting the engine.
    - If there is a problem, check that the correct starter relay switch repair kit was used.
  7. Proceed to the **IDENTIFICATION** section of this bulletin.

**MULTI-MODEL: STARTER RELAY SWITCH #1**  
**JULY 2015**

**IDENTIFICATION**

After you have completed the inspection (starter relay switch OK) or inspection/repair procedure (starter relay switch replaced), find the affected model below and follow the instructions.

**NSS300/A**

Place a punch mark after the last character of the frame serial number, stamped on the rear of the frame inside the luggage box as shown.

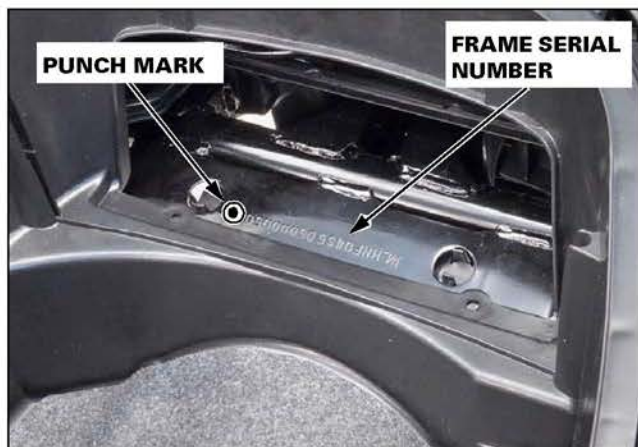

**CB300F**

Place a punch mark on the frame, next to the Safety Certification Label, nearby the VIN as shown.



**CRF250L\*, CBR300R/RA, CBR600RR/RA**

Place a punch mark after the last character of the stamped frame serial number as shown.

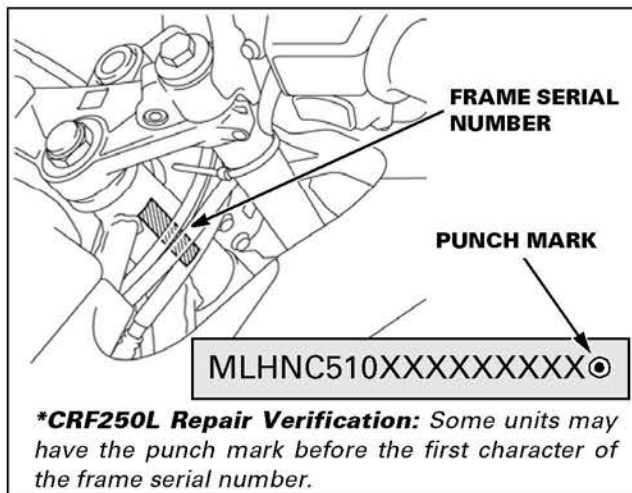

**CB500F/FA**

Place a punch mark on the frame, next to the Safety Certification Label, nearby the VIN as shown.



**CB500X/XA**

Place a punch mark on the frame, next to the Safety Certification Label, nearby the VIN as shown.

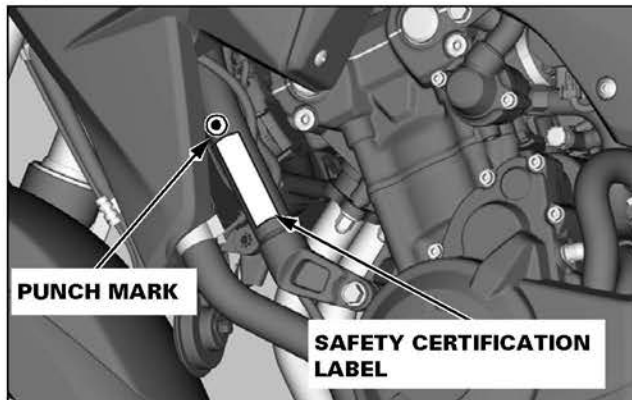

**CBR500R/RA**

Place a punch mark on the engine before the first character of the engine number as shown.

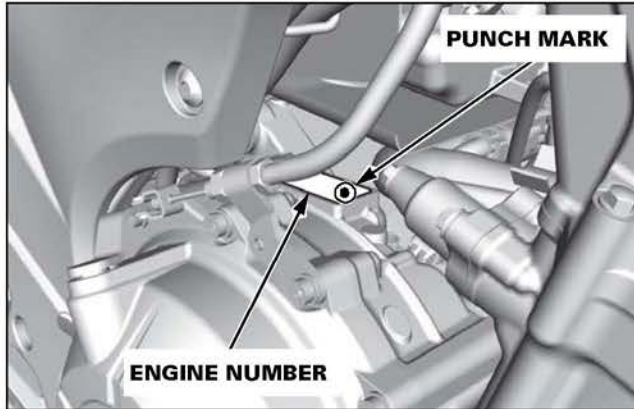

**CBR650F/FA\***

Place a punch mark on the frame, next to the Safety Certification Label, nearby the VIN as shown.

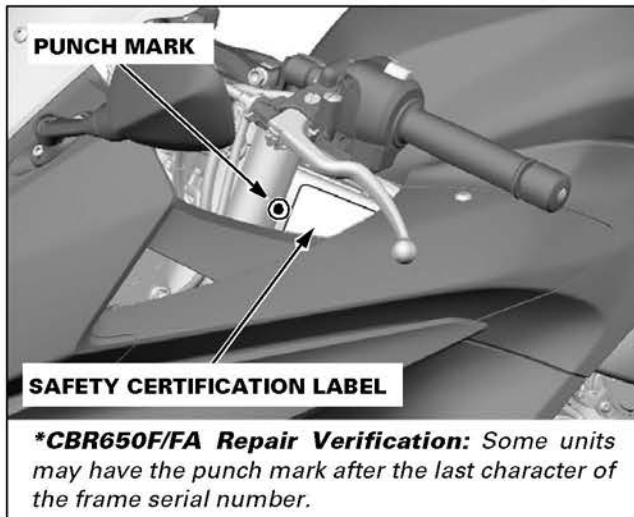

**ST1300PA**

Place a punch mark on the frame at the top edge of the frame serial number boss as shown.

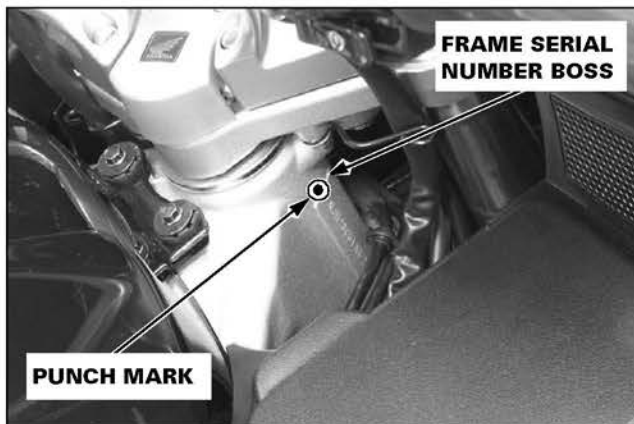

**CTX700/D, CTX700N/ND\*, NC700X/XD, NC700JD (NM4)**

Place a punch mark on the frame next to the color label (located under the seat) as shown.

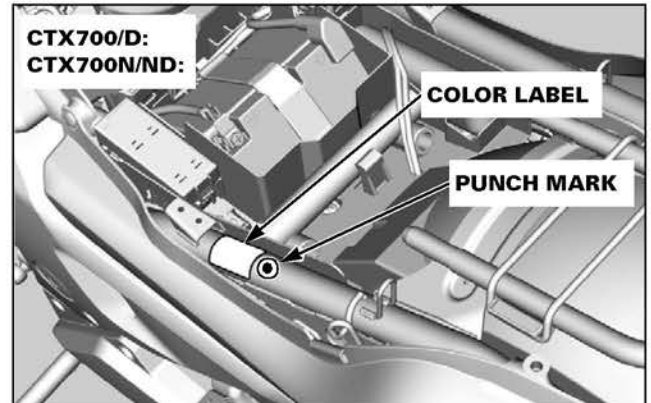

**\*CTX700N/ND Repair Verification:** Some units may have the punch mark after the last character of the frame serial number.

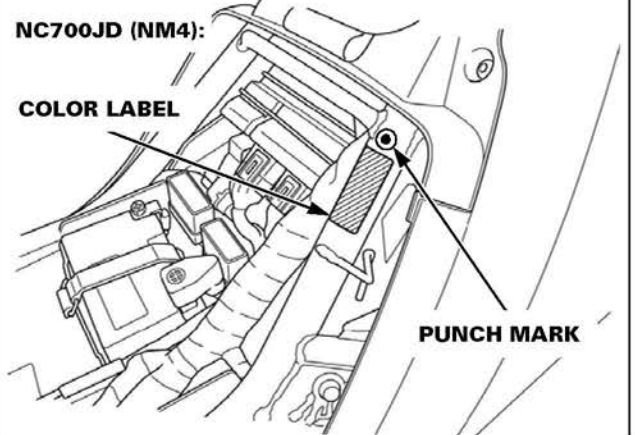
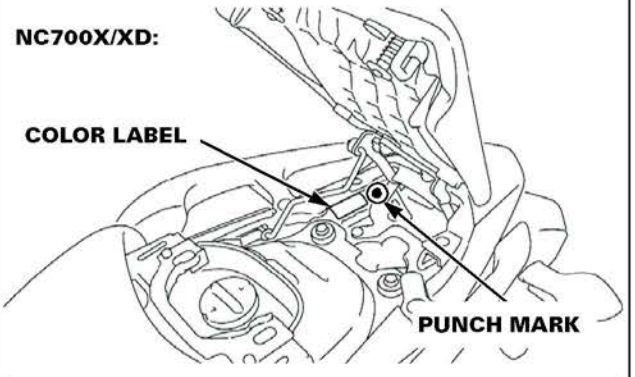

# MULTI-MODEL: STARTER RELAY SWITCH #1

## JULY 2015

### VT750C/CA, VT750CS, VT750C2, VT750C2B, VT750C2F, VT750C2S

Place a punch mark after the last character of the stamped frame serial number as shown.

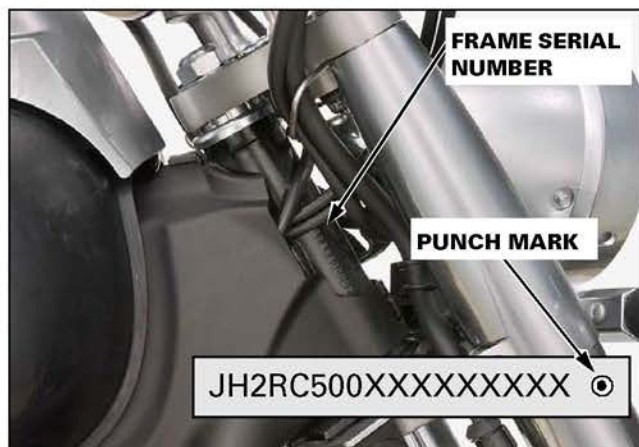

**VT750 Repair Verification:** Some models have the frame serial number running top-to-bottom, others have it running bottom-to-top; therefore the punch mark may appear above or below the frame serial number.

### VT1300CX/CXA, VT1300CR/CRA, VT1300CT/CTA

Place a punch mark after the last character of the stamped frame serial number as shown.

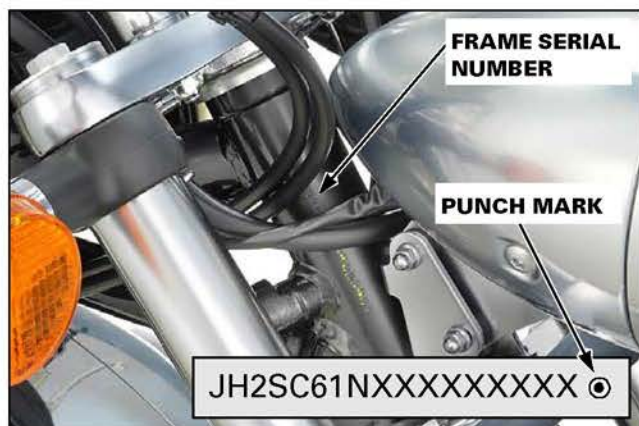

## PARTS INFORMATION

### REQUIRED PARTS

Initially, parts will be allocated to your dealership based upon your affected inventory. Later, parts will be available on open order.

#### Kit, Start Switch

P/N 06353-MR5-306

See [CLAIM](#) and [PARTS INFORMATION](#) section of this bulletin for model application.

#### Contents:

- Switch Assy., Starter Relay (1)
- Blade Fuse, Medium 30A (1)
- Blade Fuse, Medium 20A (1) **Do not use.**
- Blade Fuse, Medium 15A (1) **Do not use.**

#### Kit, Start Switch

P/N 06353-MT4-306

See [CLAIM](#) and [PARTS INFORMATION](#) section of this bulletin for model application.

#### Contents:

- Switch Assy., Starter Relay (1)
- Blade Fuse, Medium 30A (1)
- Blade Fuse, Medium 20A (1) **Do not use.**
- Blade Fuse, Medium 15A (1) **Do not use.**

## DEALER SUPPORT

### Technical Questions

If you have any technical questions relating to identification/repair procedures, repair verification (punch marks), or parts information, please contact:

Motorcycle TechLine Online:

**iN > Service > TechLine > TechLine Connect**

Or call (800) 421-1900, option 9

### Warranty Questions

If you have any warranty administration questions relating to warranty claim templates and claim filing procedures, please call:

Motorcycle Warranty, (800) 421-1900, option 7

**CLAIM AND PARTS INFORMATION**

Use the table below to find the Flat Rate Time (FRT), Warranty Claim Template, and replacement part number for the model at hand.

<b>Model</b>	<b>FRT (Same for both procedures)</b>	<b>Claim Template (Inspection Only)</b>	<b>Claim Template (Inspect and Replace)</b>	<b>Replacement Part Number</b>
<b>CRF250L</b>	0.3 hrs	JS9A	JS9B	06353-MT4-306
<b>CB300F</b>	0.4 hrs	JS9C	JS9D	06353-MR5-306
<b>CBR300R/RA</b>	0.4 hrs	JS9C	JS9D	06353-MR5-306
<b>NSS300/A</b>	0.3 hrs	JT0(Zero)A	JT0(Zero)B	06353-MR5-306
<b>CB500F/FA</b>	0.3 hrs	JS9E	JS9F	06353-MT4-306
<b>CB500X/XA</b>	0.3 hrs	JS9E	JS9F	06353-MT4-306
<b>CBR500R/RA</b>	0.3 hrs	JS9E	JS9F	06353-MT4-306
<b>CBR600RR/RA</b>	0.3 hrs	JS9G	JS9H	06353-MR5-306
<b>CBR650F/FA</b>	0.3 hrs	JS9J	JS9K	06353-MT4-306
<b>CTX700/D</b>	0.2 hrs	JS9N	JS9P	06353-MT4-306
<b>CTX700N/ND</b>	0.2 hrs	JS9N	JS9P	06353-MT4-306
<b>NC700X/XD</b>	0.3 hrs	JS9Q	JS9R	06353-MR5-306
<b>NC700JD (NM4)</b>	0.2 hrs	JS9S	JS9T	06353-MT4-306
<b>VT750C/CA</b>	0.3 hrs	JS9L	JS9M	06353-MT4-306
<b>VT750CS</b>	0.3 hrs	JS9L	JS9M	06353-MT4-306
<b>VT750C2</b>	0.3 hrs	JS9L	JS9M	06353-MT4-306
<b>VT750C2B</b>	0.3 hrs	JS9L	JS9M	06353-MT4-306
<b>VT750C2F</b>	0.3 hrs	JS9L	JS9M	06353-MT4-306
<b>VT750C2S</b>	0.3 hrs	JS9L	JS9M	06353-MT4-306
<b>ST1300PA</b>	0.4 hrs	JS9V	JS9W	06353-MT4-306
<b>VT1300CX/CXA</b>	0.3 hrs	JS9X	JS9Y	06353-MT4-306
<b>VT1300CR/CRA</b>	0.3 hrs	JS9X	JS9Y	06353-MT4-306
<b>VT1300CT/CTA</b>	0.3 hrs	JS9X	JS9Y	06353-MT4-306

**TEXT OF CUSTOMER LETTER**

**TEXT OF CUSTOMER LETTER IS FORTHCOMING**

**TEXT OF CUSTOMER LETTER**

**Request For Reimbursement**

**Multiple Models: Starter Relay Switch Inspection/Replacement**

**Use this form only if you have previously paid for this repair.** If you meet the following qualifications, American Honda Motor Co., Inc. will reimburse you for the cost of the **starter relay switch** replacement. No reimbursement will be made for other costs or repairs.

1. The vehicle must be an affected Honda motorcycle or scooter identified in the Honda Service Bulletin, *Multi-Model: Starter Relay Switch #1*.
2. The repair must have been required due to the failure that is the subject of this recall. Unrelated repairs will not be reimbursed.
- 3. The previous starter relay switch repair must have occurred before August 21, 2015.**
4. You must have a repair bill showing itemized parts and labor costs, the model, year, VIN, name, address and phone number of the repair shop, and the date of the repair. There must be verification of payment, such as a copy of a cancelled check, cash receipt, or paid invoice.
5. To qualify for reimbursement, it is not necessary that you still own the affected Honda motorcycle or scooter, but you must have been the owner when the starter relay switch was replaced. Only the owner at the time of the repair may request reimbursement. Do not request reimbursement for the expenses of any other owner.

IF YOU QUALIFY FOR REIMBURSEMENT:

Fill in the blanks; please print clearly.

Name: \_\_\_\_\_

Street Address: \_\_\_\_\_

City: \_\_\_\_\_ State: \_\_\_\_\_ Zip Code: \_\_\_\_\_

Telephone: \_\_\_\_\_ E-mail: \_\_\_\_\_

Vehicle Identification Number (VIN): \_\_\_\_\_

Total Amount Requested: \_\_\_\_\_

Mail this form together with a copy of your repair bill and verification of payment to:

**American Honda Motor Co., Inc.  
Customer Support, M/S 100-4C-7B  
1919 Torrance Blvd.  
Torrance, CA 90501-2746**

**Please allow 6–8 weeks for reimbursement processing.**

**This form is provided for dealer information and customer photocopies if needed.**

MTB 15508 (1507)