

TECHNICAL BULLETIN

LTB00746NAS2

29 SEP 2015



© Jaguar Land Rover North America, LLC

NOTE: The information in Technical Bulletins is intended for use by trained, professional Technicians with the knowledge, tools, and equipment required to do the job properly and safely. It informs these Technicians of conditions that may occur on some vehicles, or provides information that could assist in proper vehicle service. The procedures should not be performed by 'do-it-yourselfers'. If you are not a Retailer, do not assume that a condition described affects your vehicle. Contact an authorized Land Rover service facility to determine whether this bulletin applies to a specific vehicle.

This reissue replaces all previous versions. Please destroy all previous versions.

Changes are highlighted in gray

SECTION: 501-10

'Creak' Noise From Front Seat Frame

AFFECTED VEHICLE RANGE:

Range Rover Evoque (LV)

Model Year: 2012 Onwards
VIN: 000447 Onwards
Manufacturing Plant: Halewood

Range Rover Sport (LW)

Model Year: 2014 Onwards
VIN: 001154 Onwards
Manufacturing Plant: Solihull

Range Rover (LG)

Model Year: 2013 Onwards
VIN: 001204 Onwards
Manufacturing Plant: Solihull

MARKETS:

NAS

CONDITION SUMMARY:

Situation: A 'creak' noise from the front seat may be evident.

Cause: This may be caused by metal-to-metal contact between the seat suspension mat hooks and the seat frame and may be verified by visual inspection of seat support mat location hole wear.

Action: Should a customer express this concern, follow the Service Instruction outlined below.

PARTS:

LR072505	Bush suspension mat	Quantity: 4
LR026575	Seat bolts	Quantity: 4

TOOLS:

No Tools Required

WARRANTY:



NOTE: Repair procedures are under constant review, and therefore times are subject to change; those quoted here must be taken as guidance only. Always refer to TOPIx to obtain the latest repair time.



NOTE: DDW requires the use of causal part numbers. Labor only claims must show the causal

part number with a quantity of zero.

DESCRIPTION	SRO	TIME (HOURS)	CONDITION CODE	CAUSAL PART
Front seat - Remove for access & refit - Range Rover Evoque (L538)	78.10.44.99	0.2	01	LR027165
Front seat - Remove for access & refit - Range Rover Sport (L494); Range Rover (L405)	78.10.44.99	0.3	01	LR027165
Install four (4) front seat suspension mat bushes	05.10.20	0.2	01	LR027165

 **NOTE: Normal Warranty procedures apply.**

SERVICE INSTRUCTION:

- 1  **NOTE: it may be necessary to have the person sitting on the seat to move their body weight up and down on the seat cushion in order to determine the creak.**

With one person sitting in the seat, look under the seat to observe the interaction between the seat suspension mat hooks and the seat frame.

- Only continue with this Service Instruction if metal-to-metal noise is evident.

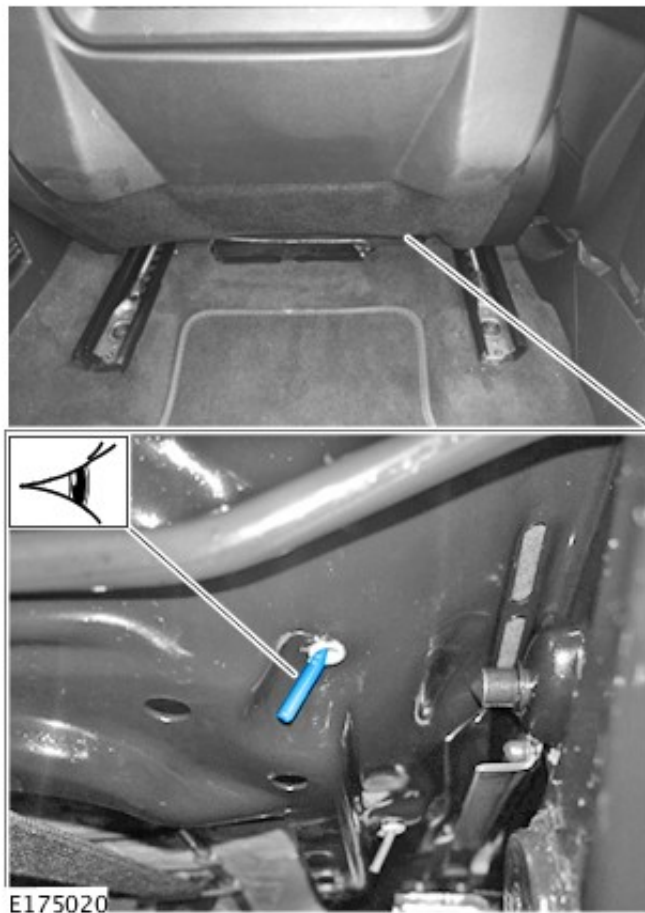

- 2 Remove the front seat (see TOPIx Workshop Manual, section 501-10).

- 3  **NOTE: if equipped.**

 **NOTE: some variation in the illustrations may occur, but the essential information is always correct.**

Remove the right-hand seat tilt adjuster.

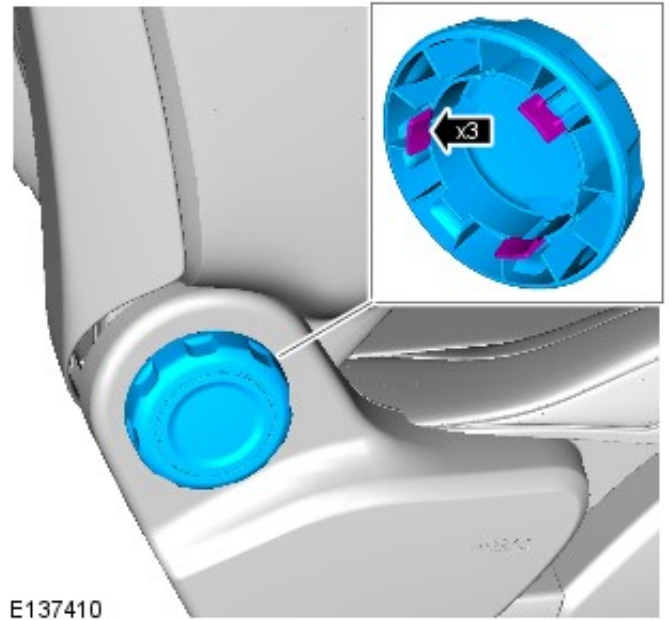

4Remove the right-hand seat cushion plastic valances.

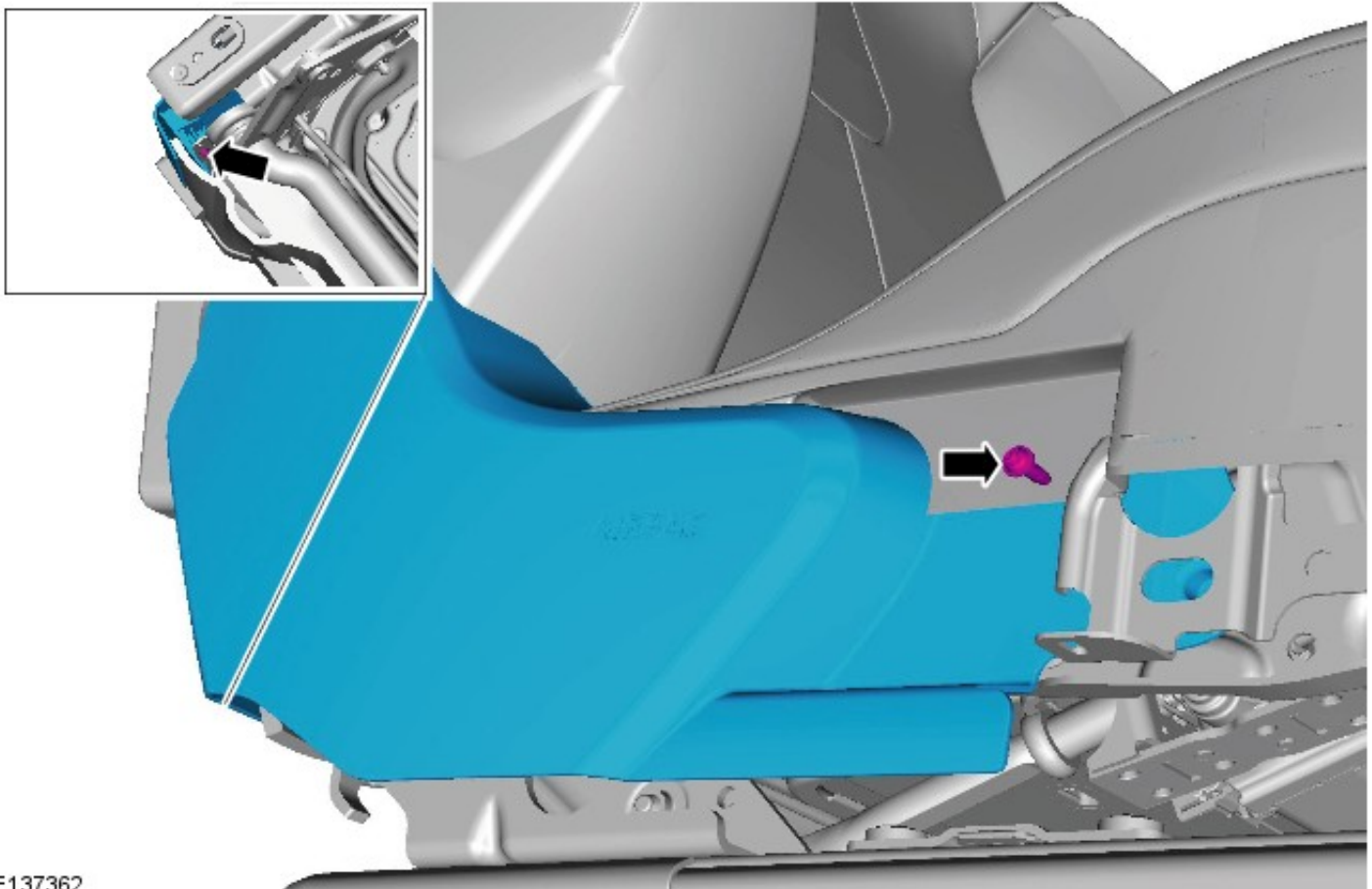

5Remove the left-hand seat cushion plastic valances.

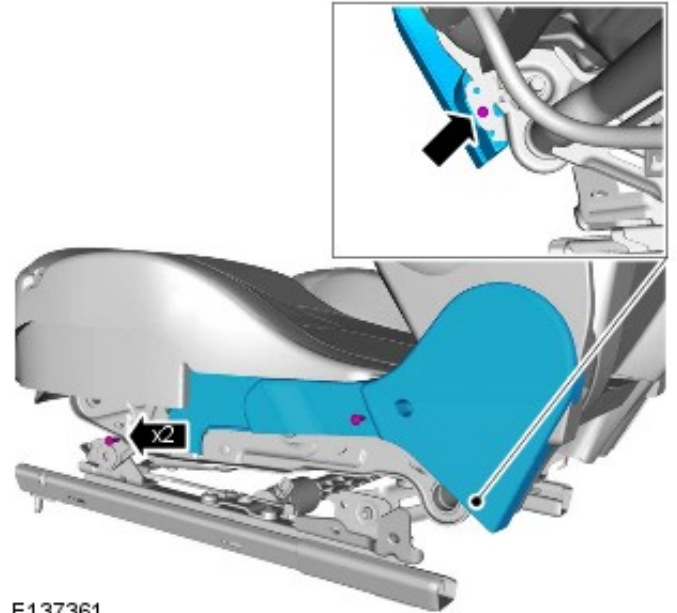

E137361

6Release the front and side edges of the cushion.

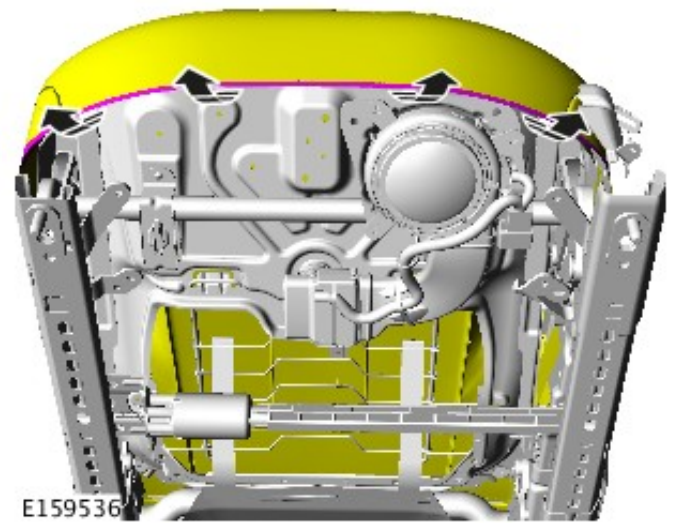

E159536

7Remove the seat cushion.

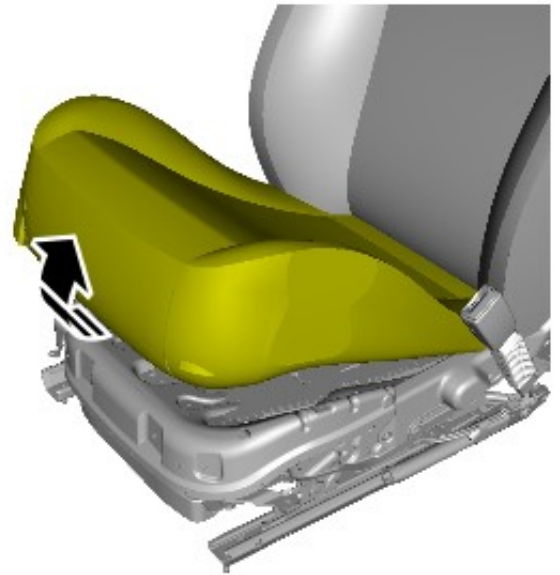

E141091

8 Unhook the seat suspension mat and position to one side.

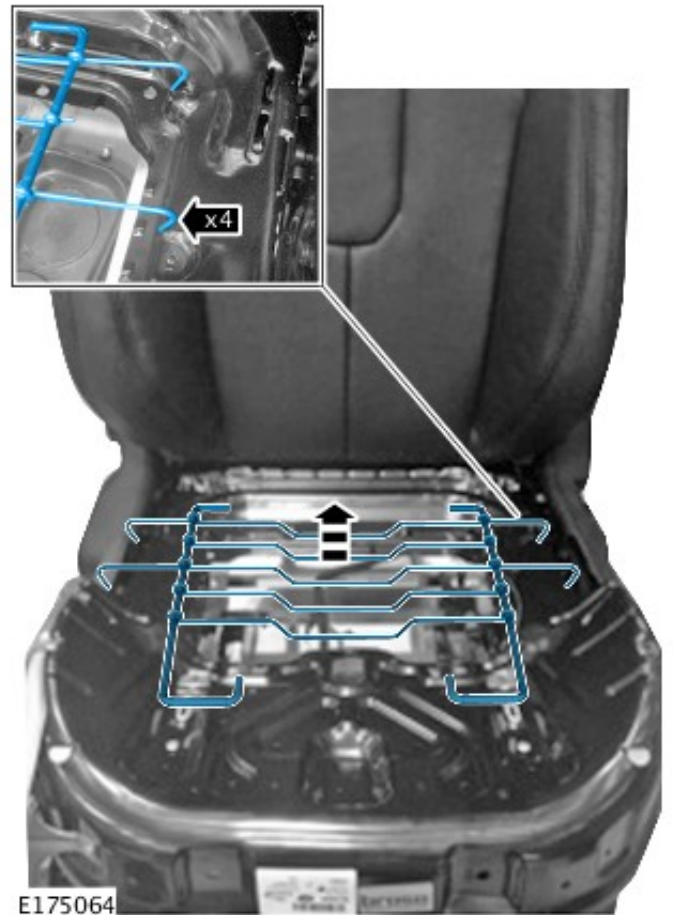

9 Using a suitable 4mm drill, drill a pilot hole to the four (4) suspension mat fixation holes.

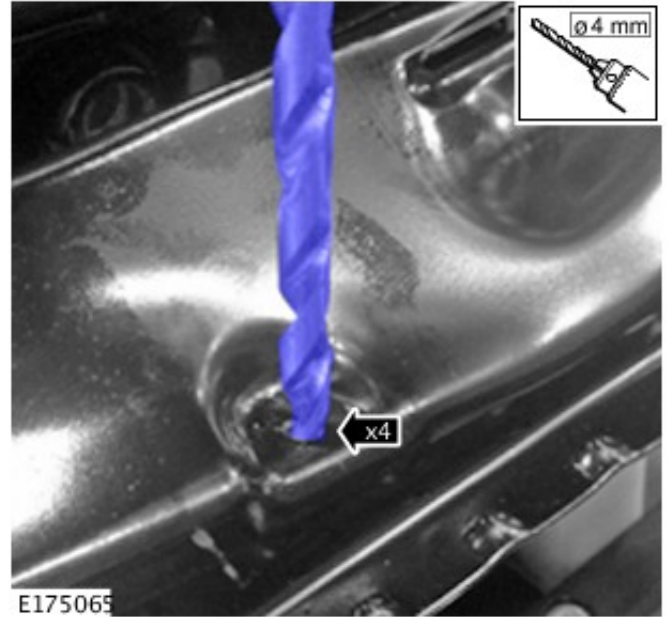

10 Using a suitable 5.5mm drill, drill the four (4) suspension mat fixation holes.

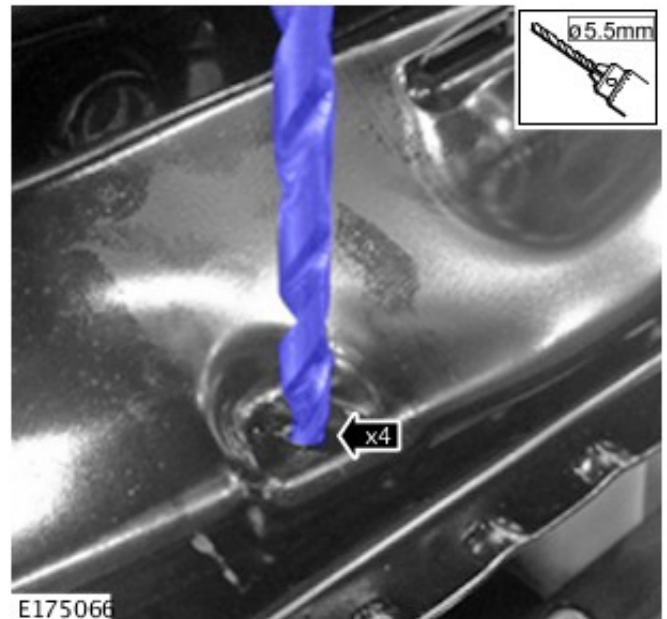

- 11** Using a suitable larger drill, deburr by hand both sides of the drilled holes.

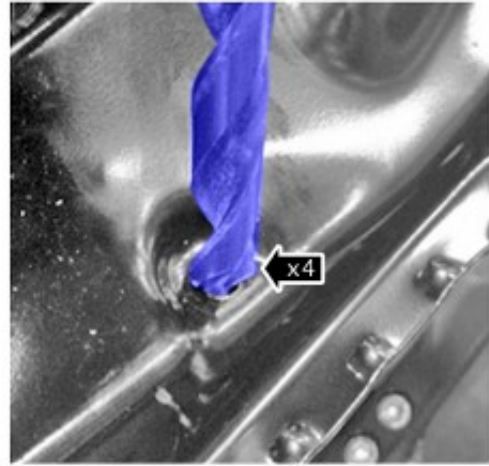

E175067

- 12** Install by hand one bush into each hole.

- Apply pressure by thumb to make sure the bush is flush with the seat frame surface.
- If required, cover the top of the bush with a large flat surface and tap the bush lightly into place.

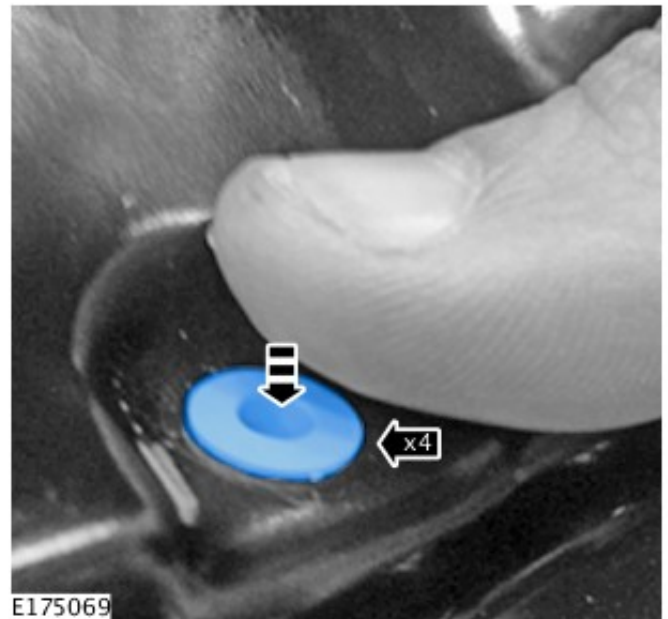

E175069

13 Install the seat suspension mat to the seat.

1. Install the suspension mat into the bushed holes.
2. Drag the suspension mat across into position.
3. Install the suspension mat to the other side.

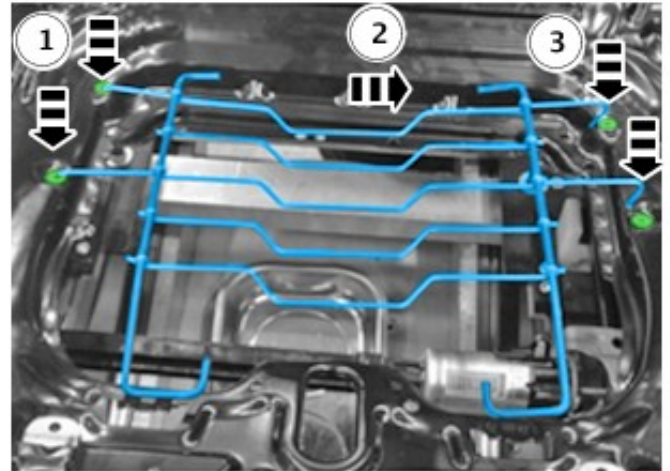

E175151

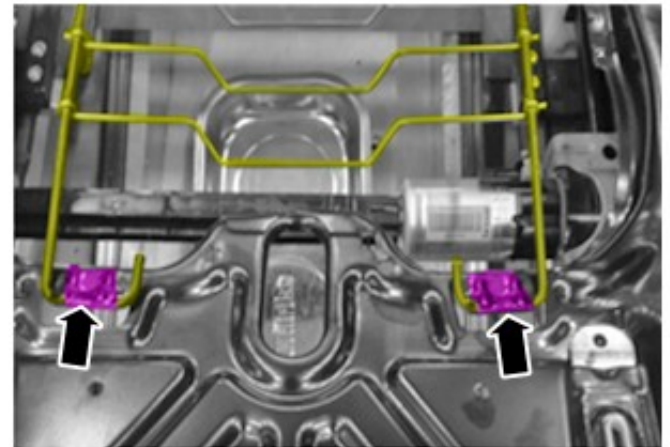
14 Make sure the two hook loop fixations to the seat frame are installed.

E175063

15To install, reverse the removal procedure.

16Install the front seat (see TOPIx Workshop Manual, section 501-10).