

TECHNICAL BULLETIN  
LTB00750NAS1  
08 APR 2015



© Jaguar Land Rover North America, LLC

NOTE: The information in Technical Bulletins is intended for use by trained, professional Technicians with the knowledge, tools, and equipment required to do the job properly and safely. It informs these Technicians of conditions that may occur on some vehicles, or provides information that could assist in proper vehicle service. The procedures should not be performed by 'do-it-yourselfers'. If you are not a Retailer, do not assume that a condition described affects your vehicle. Contact an authorized Land Rover service facility to determine whether this bulletin applies to a specific vehicle.

**SECTION: 415-01 / 01A**

'Buzz' Noise From HD Radio® After Being Switched 'ON'

**AFFECTED VEHICLE RANGE:**

**LR4 (LA)**

**Model Year:** 2010-2011

**VIN:** AA510742-BA596987

**Range Rover Sport (LS)**

**Model Year:** 2010-2011

**VIN:** AA212147-BA717165

**Range Rover (LM)**

**Model Year:** 2010-2012

**VIN:** AA304426-CA393639

**MARKETS:**

NAS

**CONDITION SUMMARY:**

**Situation:** A loud 'buzz' noise coming from the HD Radio® shortly after being switched 'ON'.

**Cause:** This may be caused by a HD Radio® tuner module software issue.

**Action:** Should a customer express this concern, follow the appropriate Service Instruction ('A' or 'B') outlined below.

**PARTS:**

LR071711                                      HD radio tuner module - gen 1                                      Quantity: 1

**WARRANTY:**

 **NOTE:** Repair procedures are under constant review, and therefore times are subject to change; those quoted here must be taken as guidance only. Always refer to TOPIX to obtain the latest repair time.

 **NOTE:** DDW requires the use of causal part numbers. Labor only claims must show the causal part number with a quantity of zero.

DESCRIPTION	SRO	TIME (HOURS)	CONDITION CODE	CAUSAL PART
HD radio tuner module - Renew - LR4 (L319)	<b>86.50.97</b>	0.4	42	LR008322
HD radio tuner module - Renew - Range Rover Sport (L320)	<b>86.50.97</b>	0.3	42	LR008322
HD radio tuner module - Renew - Range Rover (L322)	<b>86.50.97</b>	0.4	42	LR008322

 **NOTE: Normal Warranty procedures apply.**

### **SERVICE INSTRUCTION 'A' - LR4 / Range Rover Sport ONLY**

 **NOTE: the 'HD Radio® tuner module' may also be referred to as 'Audio module'.**

1. Remove the rear right quarter trim panel (see TOPIX Workshop Manual, section 501-05).
2. Disconnect the two electrical connectors.

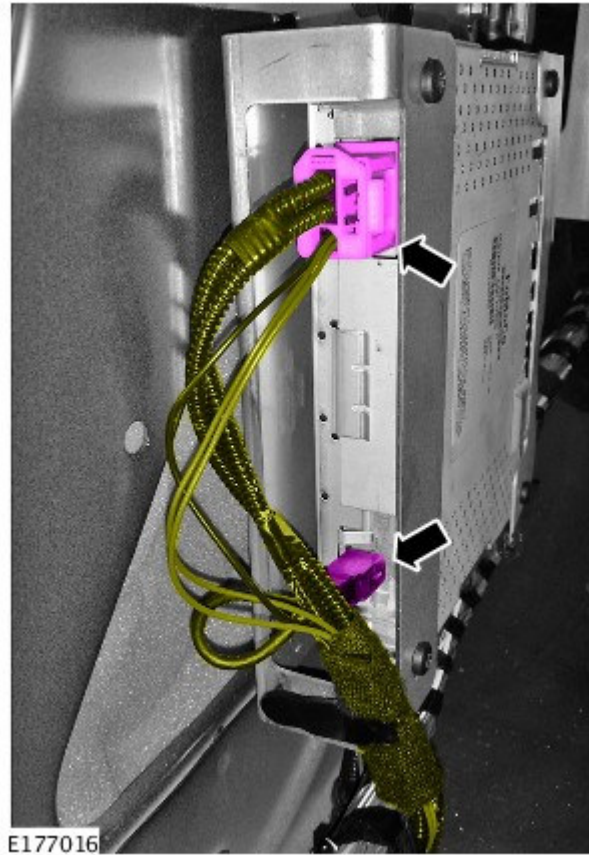

3.  **NOTE: hold the HD Radio® tuner in place when removing the four Torx bolts.**

Remove the four Torx bolts.

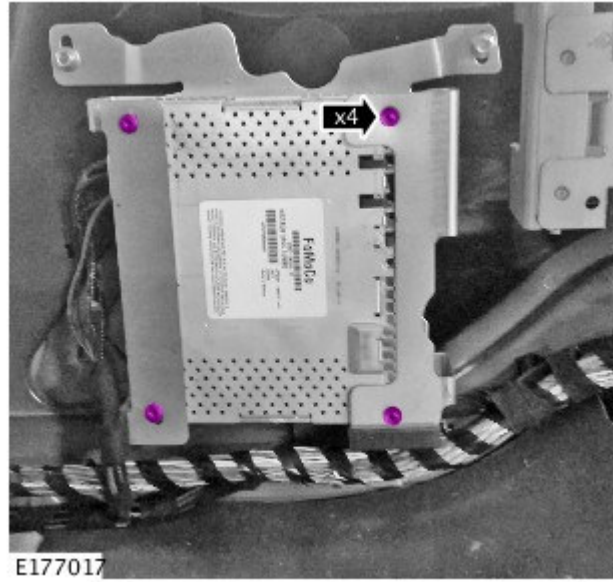

4. Remove the HD Radio® tuner module.

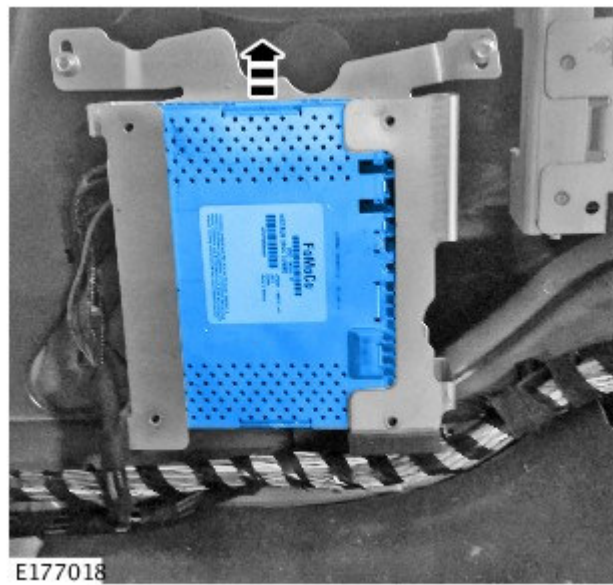

5. Install the new HD Radio® tuner module.

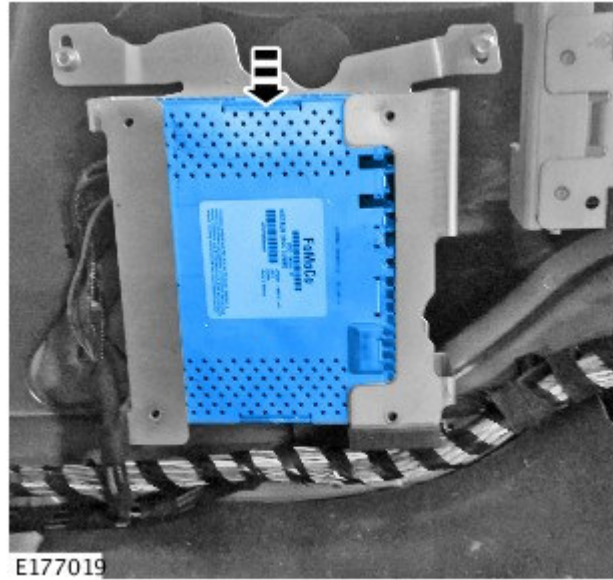

**6.** Install the four Torx bolts.

- Torque: 8 Nm

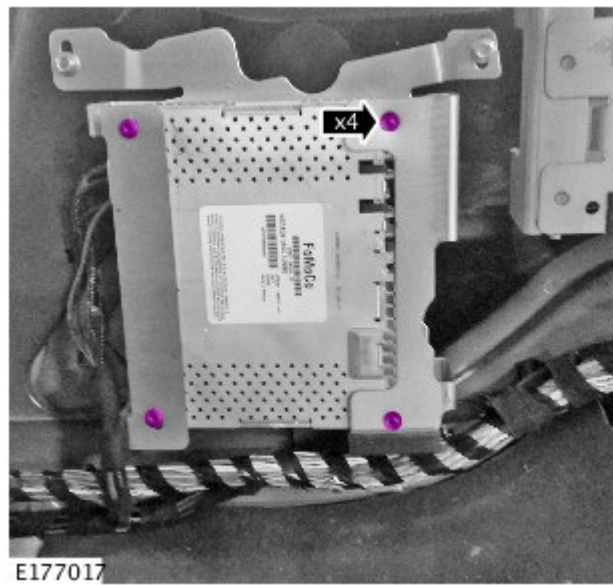

**7.** Install the two electrical connectors.

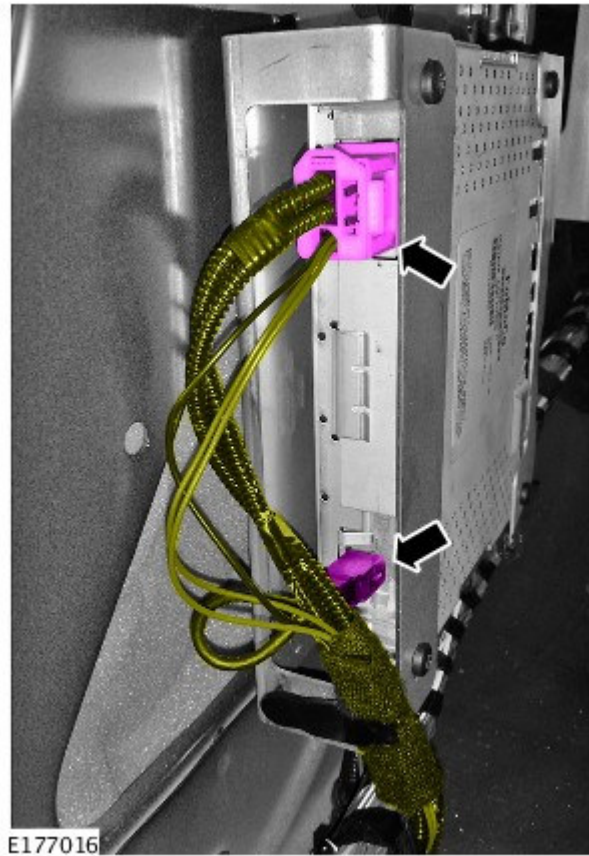

8. Instal the rear right quarter trim panel (see TOPIx Workshop Manual, section 501-05).

### **SERVICE INSTRUCTION 'B' - Range Rover ONLY**



**NOTE: the 'HD Radio® tuner module' may also be referred to as 'Audio module'.**

1. Disconnect the battery ground cable (see TOPIx Workshop Manual, section 414-00).
2. Remove the rear left quarter trim panel (see TOPIx Workshop Manual, section 501-05).
3. Remove the luggage compartment floor cover.

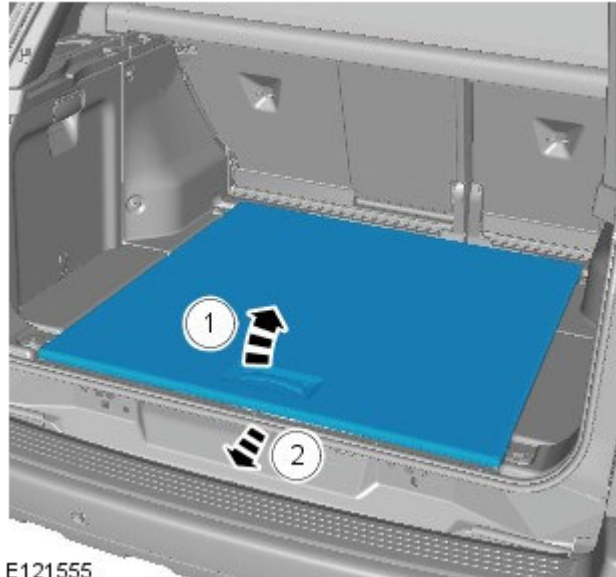

4. Remove the left side access panel.

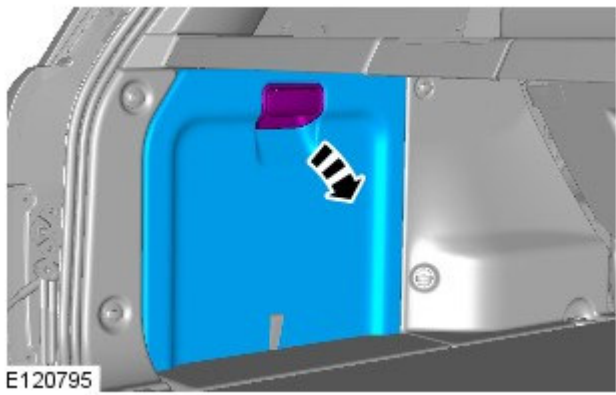

5. Remove the left side floor access panel.

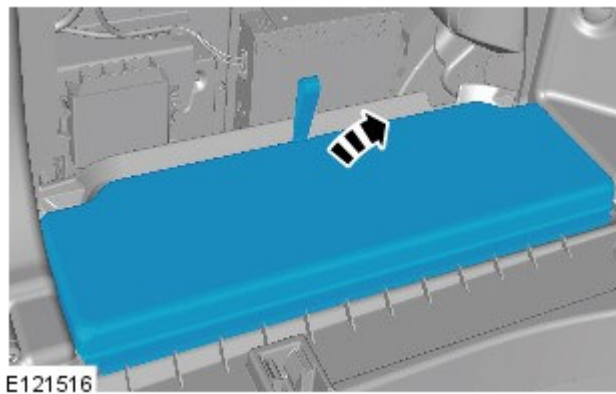

6. Remove the left side trim panel.



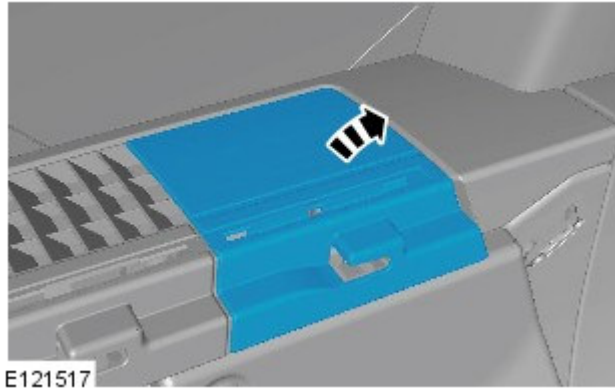

E121517

**7.** Remove the left side trim panel.

- Remove the three screws.
- Torque: 10 Nm.

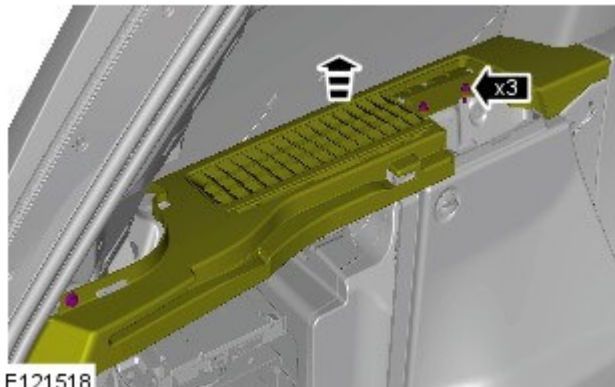

E121518

**8.** Remove the left side lower tailgate opening trim panel.

- Remove the two screws.
- Torque: 10 Nm.

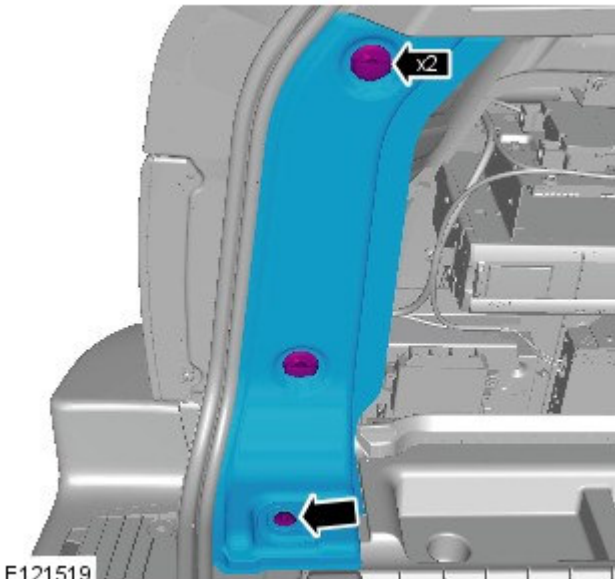

E121519

**9.** Fold down the rear left seat for access.

**10.** Remove the left side trim panel.

- Remove the two screws.
- Torque: 10 Nm.

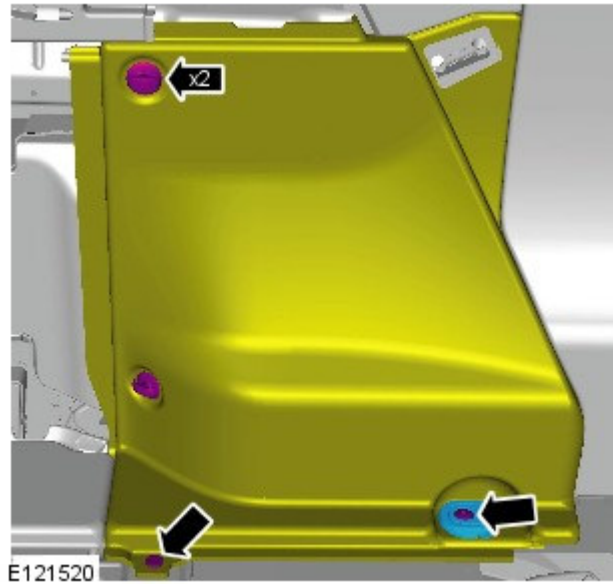

**11.** Remove the left side floor panel.

- Remove the three screws.
- Torque: 10 Nm.

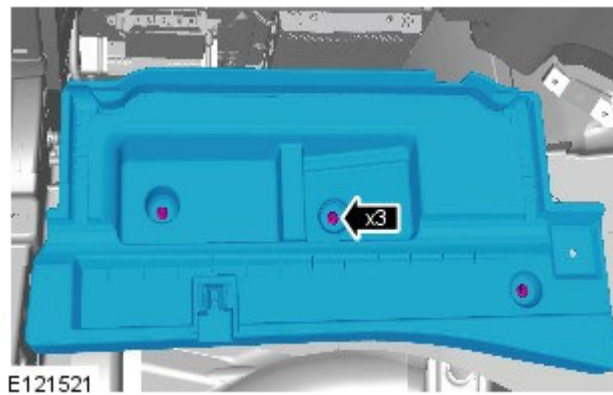

**12.**  **CAUTION: make sure that excessive force is not used. Failure to follow this instruction may result in damage to the vehicle.**

 **CAUTION: take care to not damage the wiring harnesses.**

Remove the module for access.

- Remove the two bolts.
- Torque: 10 Nm.





**13.** Disconnect the two electrical connectors.

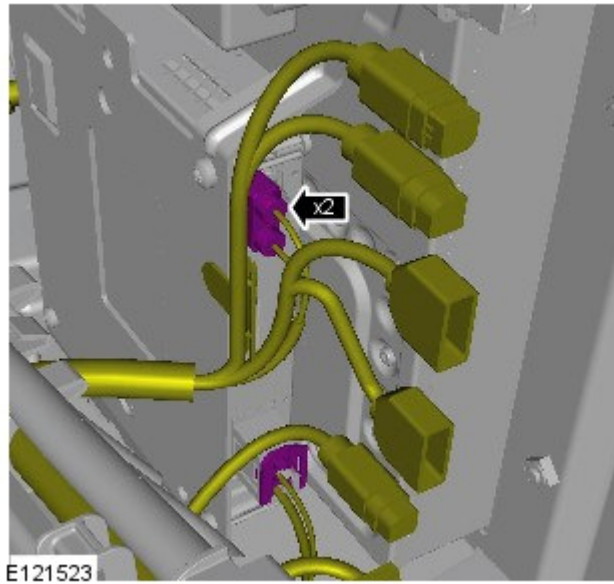

**14.** Remove the HD Radio® tuner module.

- Remove the four bolts.
- Torque: 10 Nm.

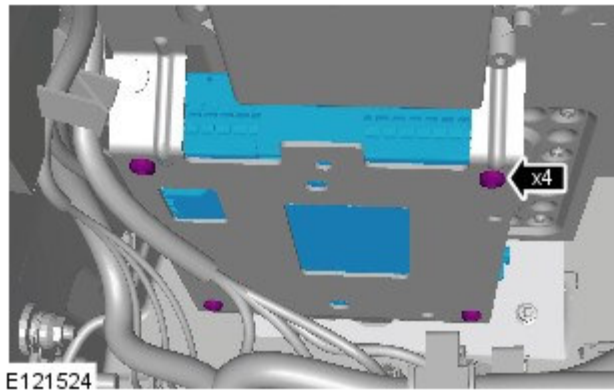

**15.** Install the new HD Radio® tuner module.

- Reverse steps 1-14.