

Tire Pressure Warning System Initialization

Service Category General

Section Pre-Delivery Service

Market USA

Lexus Supports
ASE Certification 

Applicability

YEAR(S)	MODEL(S)	ADDITIONAL INFORMATION
2016	NX200T, NX300H	

Introduction

2016 model year NX 200t and NX 300h vehicles are equipped with a direct-type Tire Pressure Warning System (TPWS). Each tire (except the compact spare tire) has a tire pressure warning valve/transmitter. Measured tire pressure data is sent to the tire pressure warning antenna by radio wave and then sent to the receiver.

During Pre-Delivery Service (PDS), the TPWS must be initialized according to the procedure in this bulletin.

Warranty Information

OP CODE	DESCRIPTION	TIME	OFF	T1	T2
N/A	Not Applicable to Warranty	-	-	-	-

Required Tools & Equipment

REQUIRED EQUIPMENT	SUPPLIER	PART NUMBER	QTY
Techstream 2.0*	ADE	TS2UNIT	1
Techstream Lite		TSLITEPDLR01	

* Essential SST.

NOTE

- Only ONE of the Techstream units listed above is required.
- Software version 10.20.030 or later is required.
- Additional Techstream units may be ordered by calling Approved Dealer Equipment (ADE) at 1-800-368-6787.

Tire Pressure Warning System Initialization

Initialization Procedure

1. Adjust all tires (except the compact spare tire, if equipped) to the standard tire inflation pressure, as indicated on the Tire and Loading Information label located inside the vehicle.

NOTE

- To adjust tire pressure correctly when outside temperature is significantly colder than shop temperature, perform a Health Check using Techstream and select the “Compensation Tire Pressure” checkbox. Compensation pressures will be displayed on the health check results screen.
- Adjust the tire pressure when the tires are cold.

Figure 1.

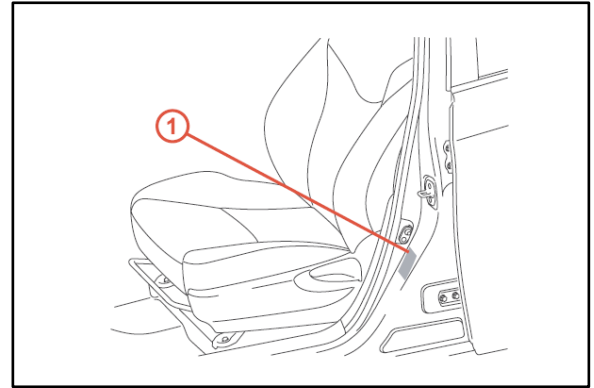

1	Tire and Loading Information Label
----------	------------------------------------

2. Cycle the ignition switch to the “IG-ON” position and use the directional arrows on the steering pad switch assembly to navigate to “TPMS” on the multi-information display.
3. With TPMS selected, press and hold the Enter Switch on the steering pad switch assembly until the Tire Pressure Warning Light blinks 3 times.

Figure 2.

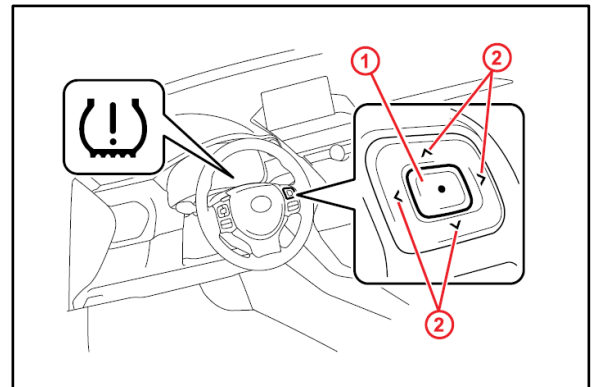

1	Enter Switch
2	Directional Arrows

4. Cycle the ignition to “OFF” and then to “IG-ON.”

Tire Pressure Warning System Initialization

Initialization Procedure (Continued)

5. Check the tire pressure values of all the tires using Techstream.

Chassis / Tire Pressure Monitor / Data List

NOTE

- The order in which the data is received is random.
- If the ignition is cycled to the “OFF” position during initialization, the Tire Pressure Warning ECU and Receiver will remember that initialization was being performed. Therefore, it will NOT be necessary to restart the initialization procedure.
- It can take 2 – 3 minutes for the tire pressure values to be displayed on the Techstream Data List. If the values are NOT displayed after a few minutes, perform troubleshooting according to the inspection procedure in the Repair Manual for DTCs C2121/21 to C2124/24 (C2121/21 to C2125/25: w/ Full Size Spare Tire).
- If the signals from all the wheels are received and the Data List “ID Tire Inflation Pressure” displays, initialization is completed.
- If initialization has NOT been completed successfully, DTC C2177/77 is stored after a vehicle speed of at least 23 mph (37 km/h) continues for 20 minutes or more. Please refer to the Repair Manual for further diagnosis.

6. Remove and discard ID number labels if attached to the wheels.