



Date	Group	No.	Release	Page
12.2015	764	863	01	1(16)

Level Control Rod Bracket, Replacement CHU, CXU

PI0863, Level Control Rod Bracket, Replacement

(December 2015)

Some MACK CHU, CXU trucks built from 06/16/2014 to 09/30/2015, and equipped with air ride suspension may have the leveling valve level control rod toggle over inadvertently. The newly designed level control rod bracket (part number 22738325) and level control valve bracket (part number 22742588) have been designed to replace the existing brackets on the affected trucks only. Follow the replacement procedure outlined in this Product Improvement (PI).

Note: This bulletin does not apply to MACK Trucks Australia.

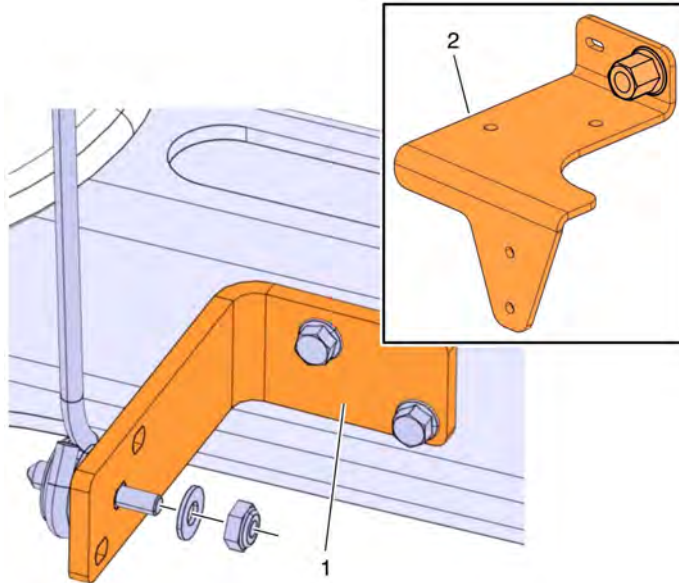

W7106181

Required Parts

Level Control Rod Bracket, Replacement Parts			
Item #	Description	Part Number	Qty
1	Level Control Rod, Bracket, Lower	22738325	1
2	Level Control Rod, Bracket, Upper	22742588	1

Level Control Rod Upper and Lower Bracket, Replacement Procedure:

You must read and understand the precautions and guidelines in Service Information, group 70, "General Safety Practices, Frame, Springs, Shocks and Springs" before performing this procedure. If you are not properly trained and certified in this procedure, ask your supervisor for training before you perform it.

DANGER

Do not attempt to repair or service this vehicle without having sufficient training, the correct service literature and the proper tools. Failure to follow this could make the vehicle unsafe and lead to serious personal injury or death.

- 1 Park the vehicle on a level surface.
- 2 Apply the parking brake.
- 3 Place the transmission in neutral or park.

4 Install the wheel chocks.

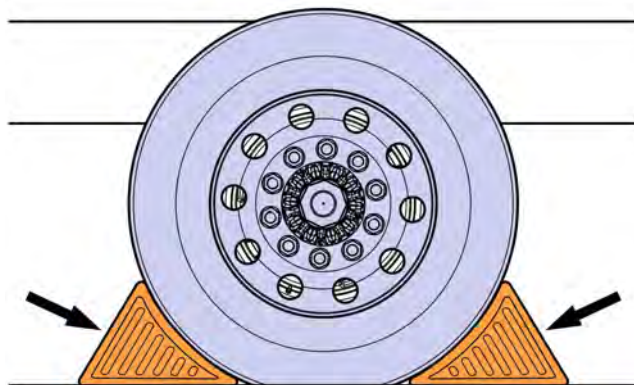

W7086748

5 Disconnect the cable from the battery's negative terminal.

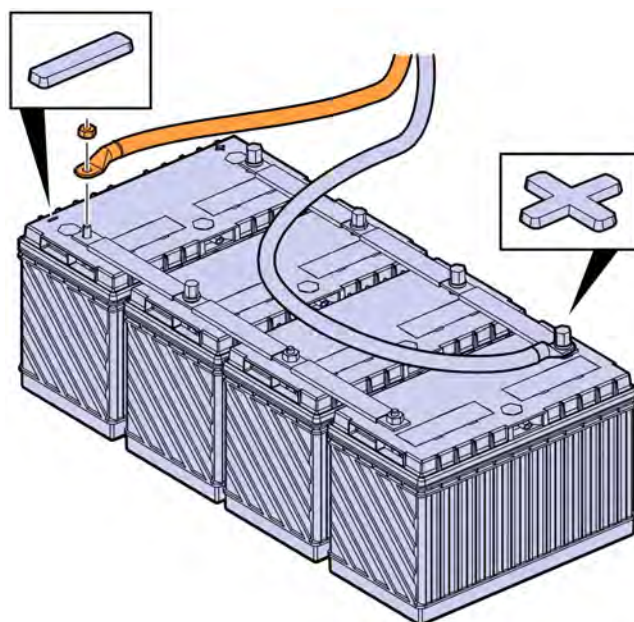

W3086747

- 6 Drain the complete air system of all pressure.
- 7 Following safe lifting procedures, lift and support the frame with jack stands.
- 8 Clip the cable ties securing the air line from the leveling valve to the left rear air spring.
- 9 Using the appropriate air line tool, remove the air line from the leveling valve to the left rear air spring.

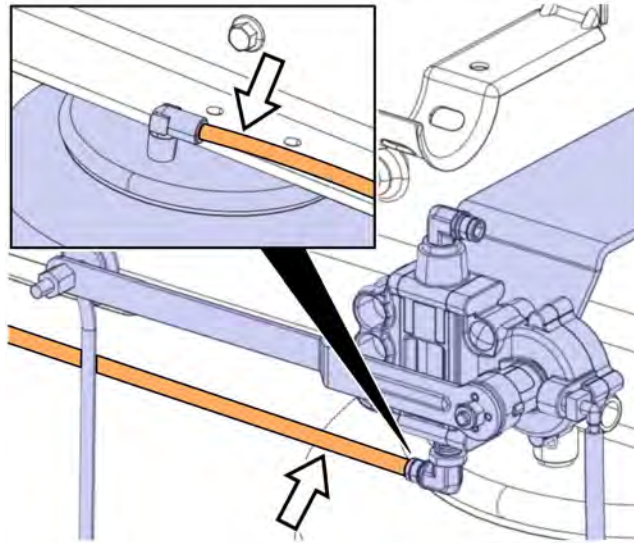

W7108155

- 10 Remove the fasteners securing the leveling valve to the upper bracket and position the valve out of the way.

Note: Do not discard the fasteners. Store them for reuse.

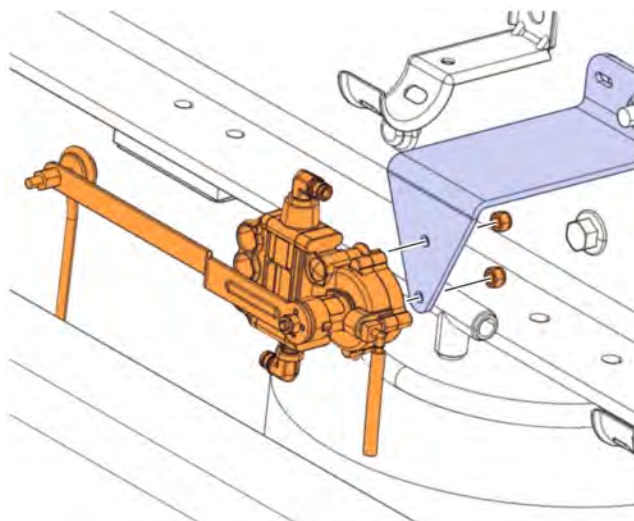

W7108156

- 11 Remove the fastener securing the leveling valve upper bracket to the frame and remove the bracket.

Note: Do not discard the fastener. Store the fasteners for reuse.

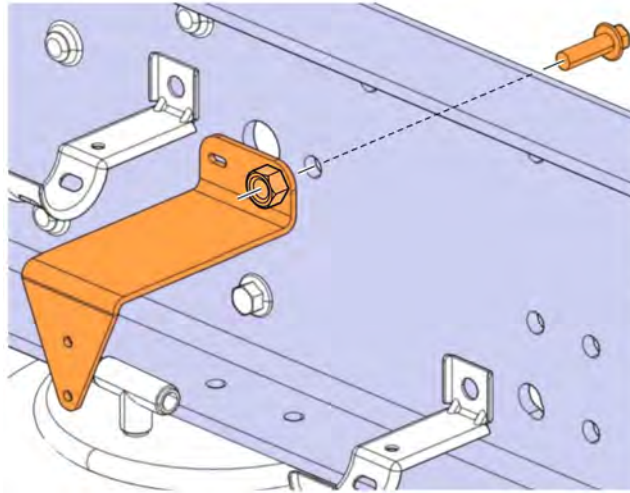

W7108157

- 12 Position replacement upper bracket (part number 22742588) on the frame and loosely install the stored fastener.

Note: Do not tighten the fastener at this time. The fastener will be tightened during the **Ride Height Adjustment Procedure**.

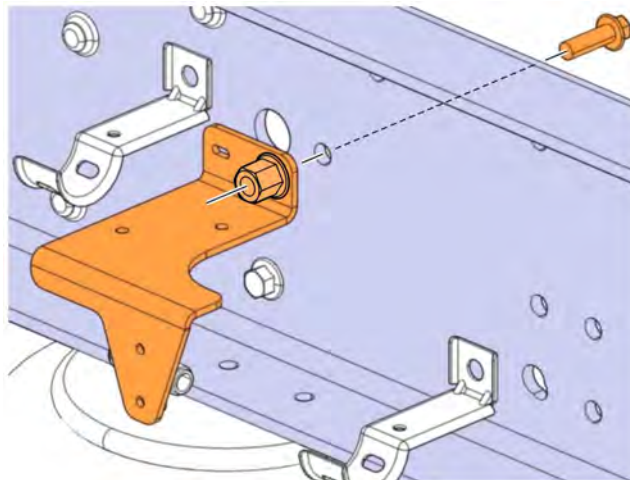

W7108158

13 Position the level control valve on the upper replacement bracket and install the stored fasteners.

14 Tighten the fasteners to 3.9 ± 0.5 Nm (35 ± 5 in-lb).

Note: Failure to tighten the fasteners to proper torque specification may result in damage to the level control valve.

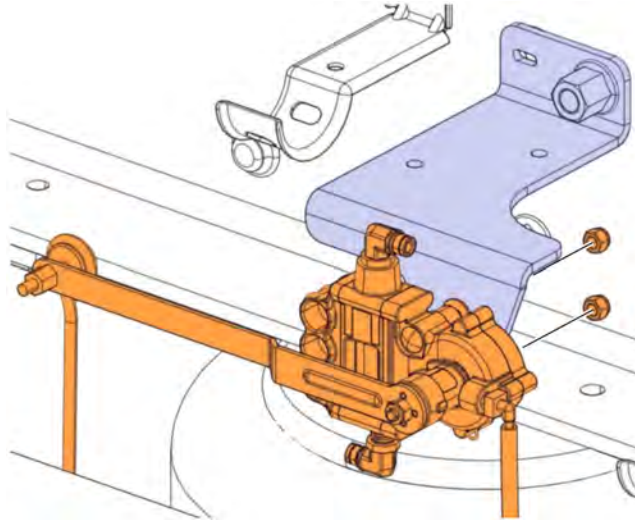

W7108159

15 Measure, cut, route, and connect a new section of 9.5 mm (.375 in) air line from the level control valve to the left rear air spring.

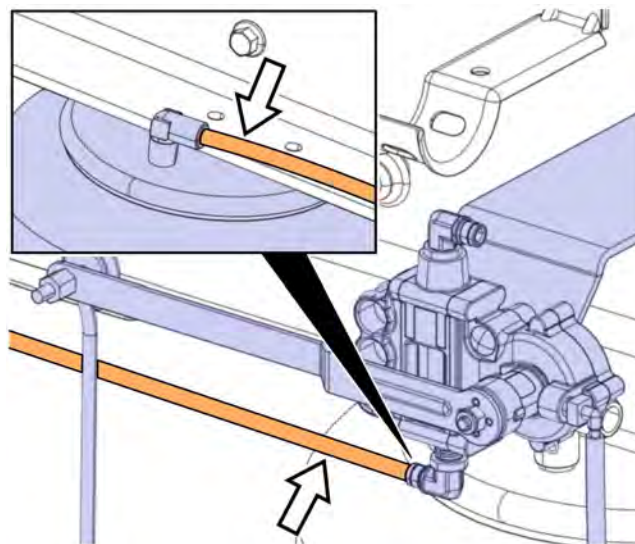

W7108155

16 Using cable ties, secure the new section of air line.

17 Remove the level control rod (2) and stud nut and washer (1) from the center hole in level control rod lower bracket.

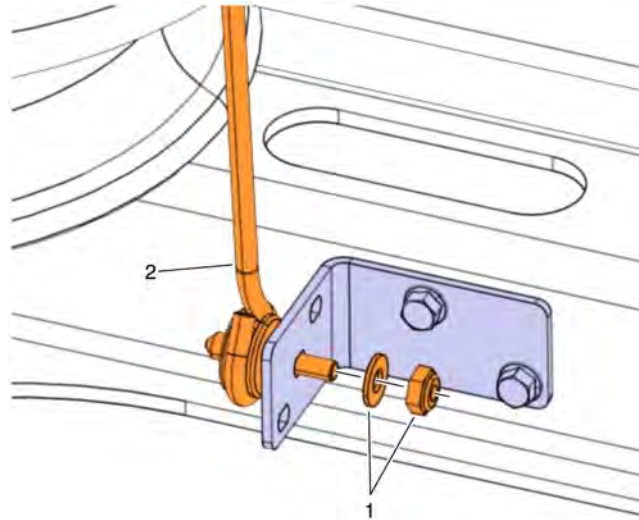

W7106174

18 Remove the fasteners securing the existing level control rod lower bracket (22389949) to the air spring cross bar bracket.

Note: Secure the fasteners for reuse during installation.

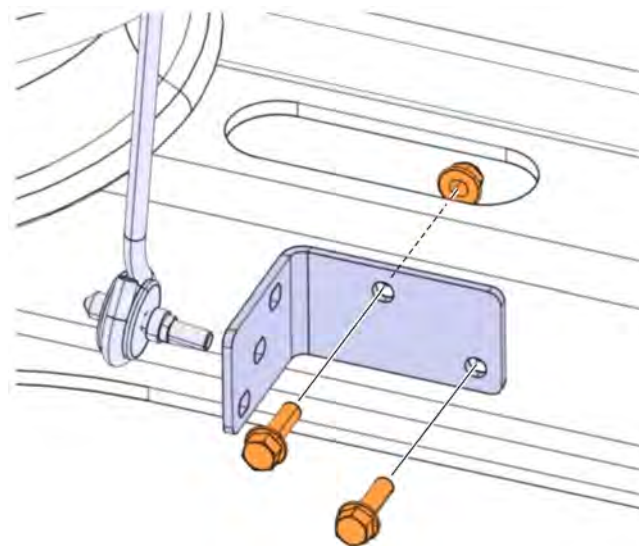

W7106175

19 Remove the existing level control rod lower bracket and discard.

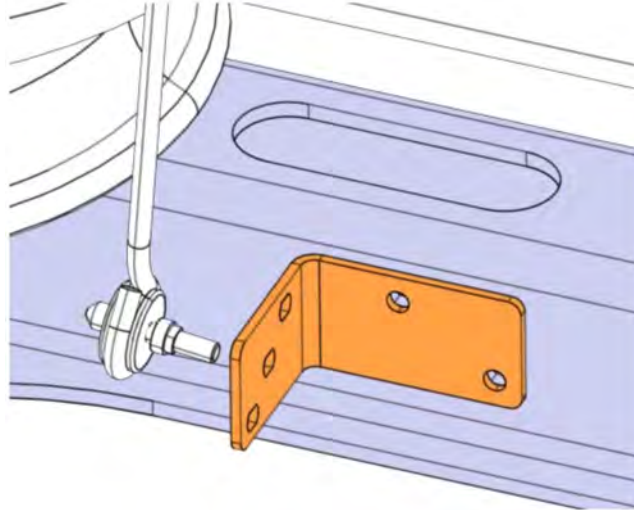

W7106176

20 Position the replacement level control rod lower bracket (part number 22738325) on the air spring cross bar bracket.

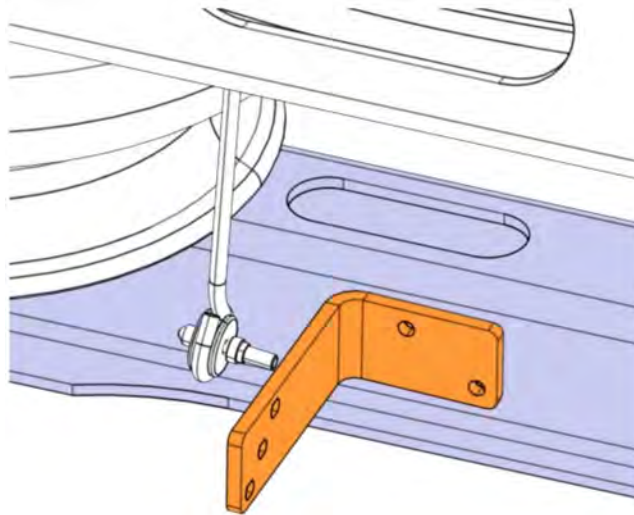

W7106177

- 21 Install the fasteners securing the level control rod lower bracket.
22 Tighten the fasteners to 10 ± 1.5 Nm (88 ± 13 in-lb).

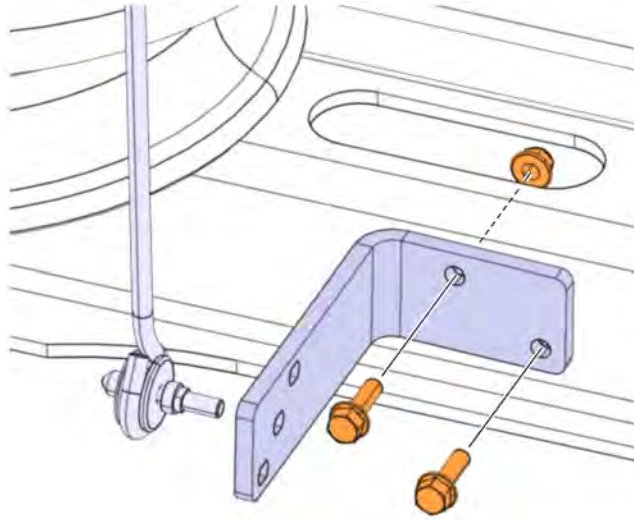

W7106178

- 23 Position the level control rod (2), stud nut and washer (1) in the middle hole on the level control rod lower bracket as shown the figure below.
24 Tighten the stud nut to 10 ± 1.5 Nm (88 ± 13 in-lb).

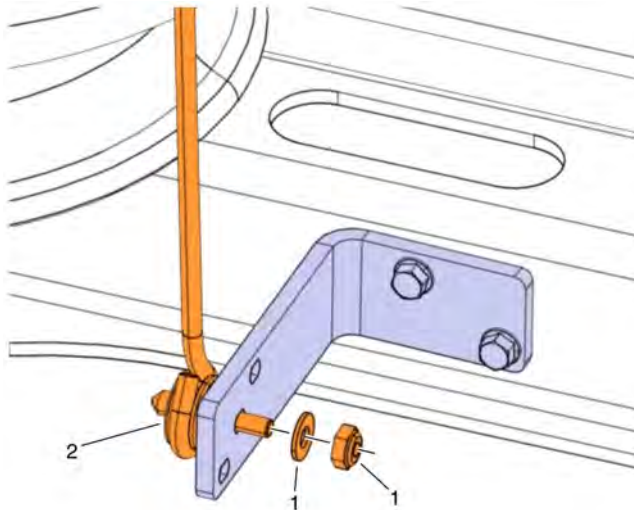

W7106179

25 Remove the jack stands and lower the truck.

26 Connect the cable to the battery's negative terminal.

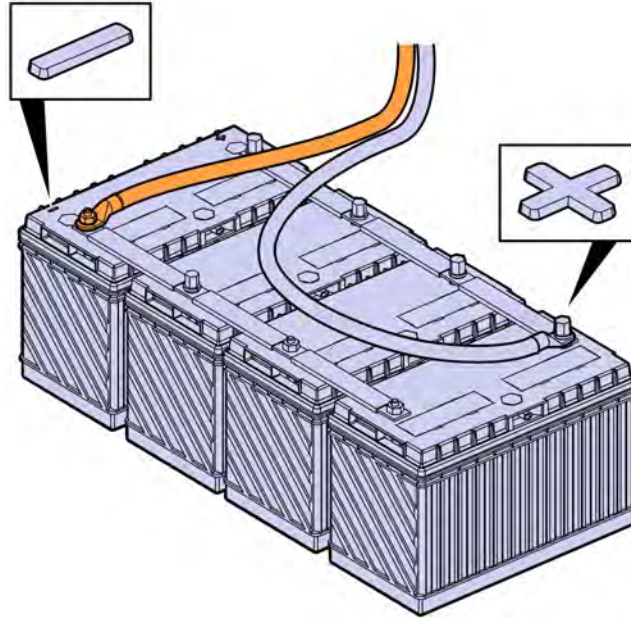

W3086758

27 Remove the wheel chocks.

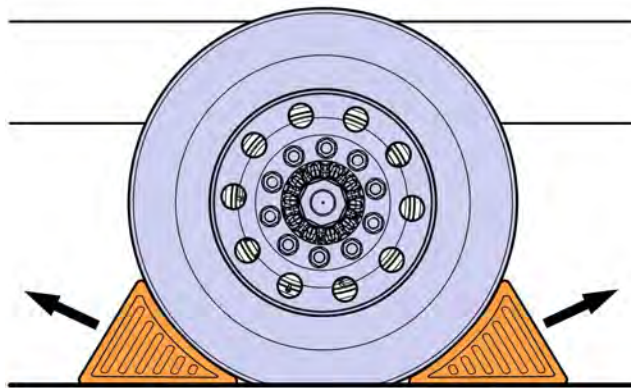

W7086759

28 Proceed to **Ride Height Adjustment and Calculations** section.

Ride Height Adjustment and Calculations

- 1 Check all tires for proper inflation. If applicable, adjust tire air pressure to tire manufacturer's specifications.
- 2 Using the dash mounted rear suspension air dump switch, release the air in the rear air springs or disconnect the leveling rod (1) from the valve lever (2), and use the valve lever (2) to release pressure from the air springs.



CAUTION

The suspension may drop quickly once pressure is released from the air springs.

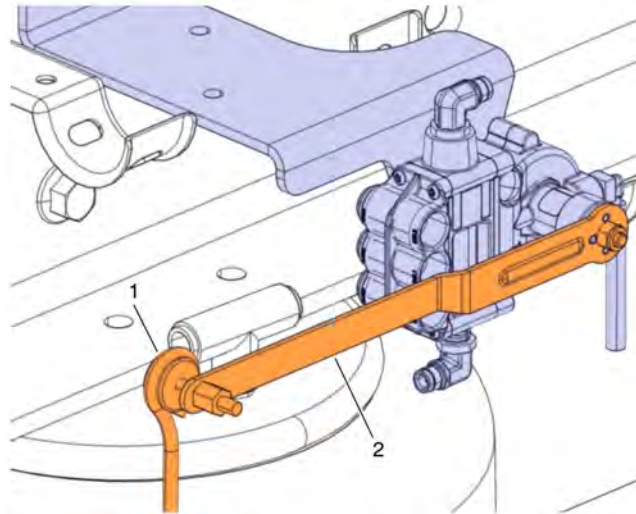

W7108160

- 3 Start the engine and allow the air system to reach the normal operating pressure of 827 kPa (120 psi).
- 4 Turn off the engine.
- 5 Inflate the rear air springs with air by using the dash mounted switch or reconnect the actuator rod to the load leveling valve lever.

Note: Ensure the air system is at a normal operating pressure of 827 kPa (120 psi).

- 6 Free and center all suspension joints by slowly moving the vehicle back and forth twice without using the brake.

Note: When coming to a complete stop, ensure the brakes (parking and service) are released.

7 Chock the front wheels.

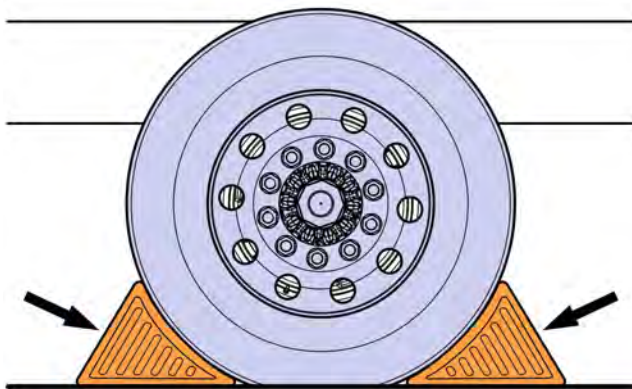

W7086748

8 Using a tape measure, measure and record the height of the frame rail.

Note: The ride height measurement is dependent on frame size.

9 Measure and record the distance from the floor to the center of the axle (Measurement – A).

10 Measure and record the distance from the bottom edge of the frame rail to the floor (Measurement – B).

11 Subtract measurement – A from measurement – B to calculate the ride height (A – B = ride height).

Note: Use the table below to determine if the truck is at the proper ride height.

Ride Height (Unloaded)		
Frame Height	Frame Type	Ride Height
266 mm (10.4 in)	RRH-220	230 mm (9.0 in) Loaded 240 mm (9.4 in) Unloaded
300 mm (11.8 in)	RRH-220	213 mm (8.4 in) Loaded 223 mm (8.8 in) Unloaded

- 12 Adjust the ride Height if needed. Slightly Loosen the fastener (1) securing the leveling valve to the frame rail.
- 13 Using the ride height adjustment tool (3) (part number J-44544), adjust the load leveling valve (2) until the ride height is within specification.

Note: The suspension ride height is adjusted by turning the load leveling valve **CLOCKWISE** (to raise) or **COUNTERCLOCKWISE** (to lower) the ride height.

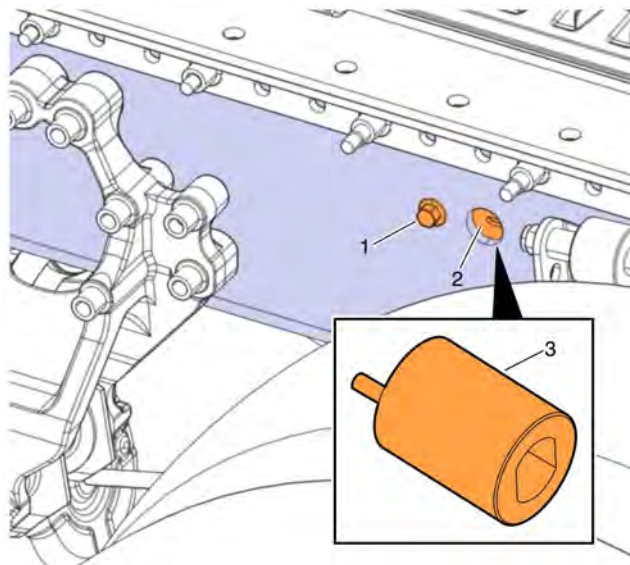

W7104611

- 14 Tighten the fastener (1) securing the load leveling valve (2) to the frame to 175 ± 40 Nm (129 ± 30 lb-ft).

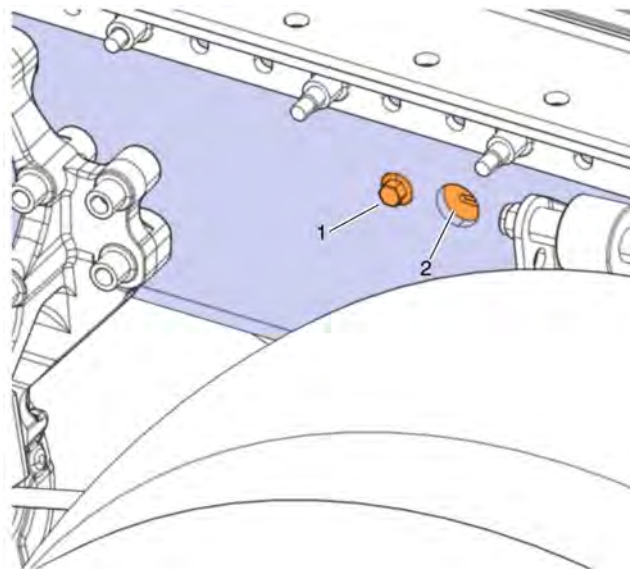

W7104656

- 15 Repeat steps 8 – 14 to validate the ride height and confirm the accuracy of the leveling valve adjustment.
- 16 Using the dash mounted rear suspension air dump switch, release the air in the rear air springs or disconnect the leveling rod (1) from the valve lever (2), and use the valve lever (2) to release pressure from the air springs.

 **CAUTION**

The suspension may drop quickly once pressure is released from the air springs.

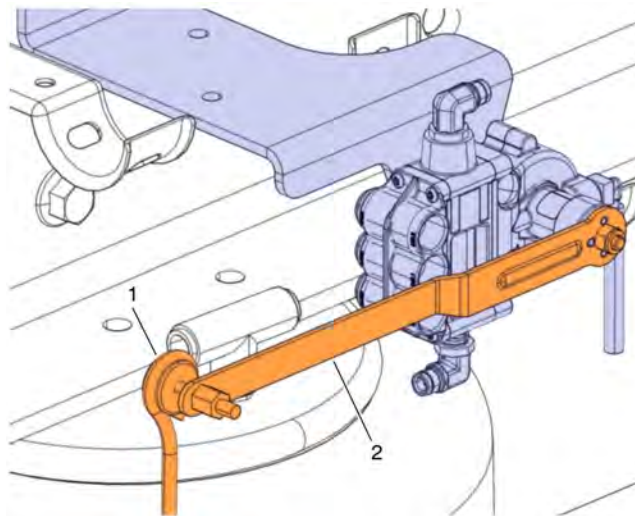

W7108160

- 17 If applicable, connect the suspension leveling rod (1) to the valve control lever (2).

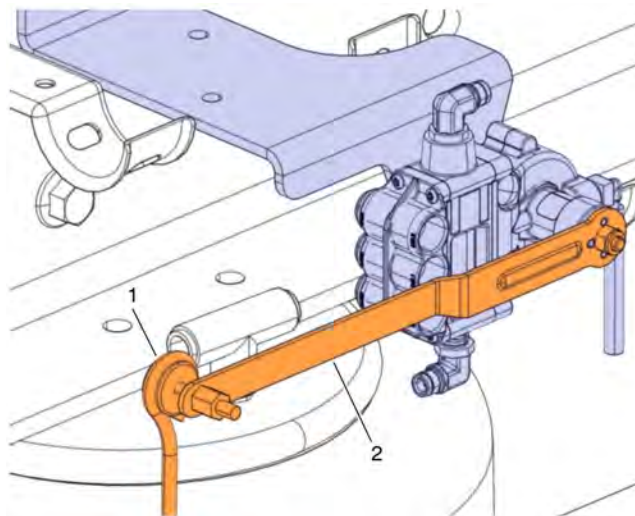

W7108160

- 18 Start the engine, build air pressure to the proper operating pressure, and stop engine.
- 19 Fill the rear air springs.

Note: Ensure the air pressure is at the proper operating pressure.

20 Using a tape measure, re-check the ride height.

Note: If the ride height is not within specifications, check the leveling valve and other suspension components for excessive wear or damage.

21 Apply the parking brake.

22 Remove the wheel chocks.

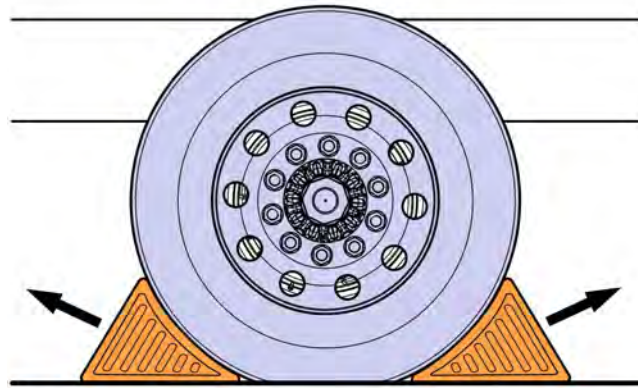

W7086759

Reimbursement

This repair is covered by an authorized Service Program. Reimbursement is obtained through the normal claim handling process.	UCHP Reimbursement	eWarranty Reimbursement
Claim Type (used only when uploading from the Dealer Bus. Sys.)	B	B
Recall Status		
Vehicle inspected, repair not required	1- Inspected OK	1- Inspected OK
Vehicle repaired per instruction	2- Modified per instruction	2- Modified per instruction
Labor Code		
Primary Labor Code (Level Control Rod Bracket, Replacement)	7647-03-09-01 1.5 hrs	1361E-01-96 1.5 hrs.
Time to take charge and determine campaign status	1700-16-01-01 0.3 hrs	101AA-0A-00 0.3 hrs
Causal Part	22389949	22389949
SCC Code	S6965	N/A
Authorization Number	N/A	PI0863
Expiration Date	01-DEC-2016	01-DEC-2016

Note: Take Charge Time is not included in the Labor Code for this operation. Take charge may be eligible but can only be used once per repair visit. If vehicle is having other warranty repairs performed, take charge should be charged to the warranty repair, otherwise take charge can be charged to this service program.