



Field Service Bulletin
Safely Working on CNG Fuel Systems

ENP-391
May 8, 2015

1. Introduction

All compressed natural gas (CNG) fuel systems include a high pressure (3600 psi) system for fuel storage and a low pressure system (125 psi) for consumption by the vehicle engine.

Understanding the characteristics of CNG and how the vehicle fuel system works will prevent personal, property and vehicle damage.

This bulletin summarizes the safety rules and procedures for safe maintenance and repair of CNG fuel systems.

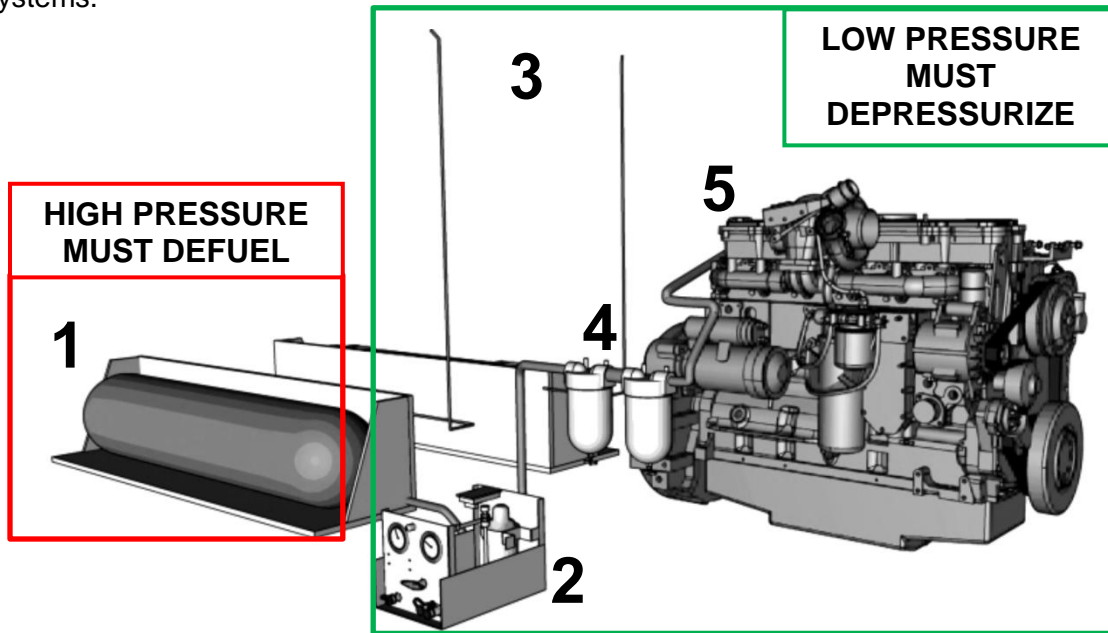

Figure 1 CNG Fuel System Pressure Zones: Red = High Pressure, Green = Low Pressure
(1) CNG storage cylinders (and pressure relief devices, PRDs), (2) fuel management module (FMM), (3) PRD vent stacks, (4) low pressure filters, (5) engine. NOTE: The low pressure filters are part of the vehicle engine, not the fuel system.

Refer to the Attachment, “CNG Pressure Zones” at the end of this bulletin for more details.



WARNING

This bulletin is a supplement to training in operation and maintenance of CNG fuel systems. Attempting to operate or maintain any CNG fuel system without proper training is dangerous.



WARNING

If the vehicle has been in an accident or fire, cylinders and system must be examined by a qualified inspector.

2. Compressed Natural Gas

Natural gas is flammable; however, it only burns within a narrow range when mixed with air in a ratio of between 5 and 15 percent. CNG will not burn in the highly concentrated form found inside the cylinders.

Natural gas is odorless, tasteless and non-toxic. That is why Mercaptan is injected into the gas – to give it that “rotten egg” odor, which helps leak detection.

Natural gas is lighter than air so it rises and diffuses into the atmosphere when released.

- Never smoke or use an open flame near a CNG vehicle.
- Don't allow sparks, flames, or heated particles to come within six feet (2m) of the vehicle.
- Never attempt to depressurize or vent a system by loosening a fitting.
- Never adjust, remove or tighten a fitting or connector on a fuel system that is under pressure.

3. Depressurize or Defuel?

Refer to Figure 1. Depending on where work must be performed, the fuel system must be either depressurized or defueled.

When working on the system downstream from the manual cylinder valve, system pressure can be isolated by closing the manual cylinder valve and **depressurizing** the system.

3.1 Components that can be isolated and require depressurizing include

1. The ball (Main Shutoff) valve on the FMM control panel
2. High pressure filter
3. Solenoid valve
4. Regulator
5. High pressure gauge
6. Low pressure gauge
7. Manifold
8. Fill receptacles
9. Defuel receptacles
10. Defuel (three-way) valve
11. Fuel lines **to** the fuel management module (FMM)

This area is shown in the green boxed area in Figure 1.

3.2 Components that cannot be isolated (always under high pressure) require defueling include:

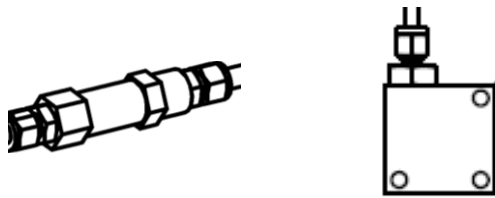

Figure 2 Two types of PRDs are in use in Agility Fuel Systems: The “cartridge type” point PRD shown at left, and the “box type” area PRD shown on the right.

1. Fuel cylinders
2. Manual cylinder valves
3. Pressure relief devices (PRDs)
4. PRD lines

When working on fuel cylinders, the manual shutoff valve mounted on the cylinders and the pressure relief devices (PRDs) – the fuel system must be **defueled** because there is no way to isolate the high pressure contained in these components. This is shown in the red boxed area in Figure 1.

4. Depressurize the System

Refer to the text and Figures 3 through 6. To depressurize the system, perform the following steps.

1. Ensure that the vehicle is turned off.
2. Locate and close all cylinder shutoff valves (turn handle fully clockwise), see Figure 3.
3. Make sure the manual shut off-valve on the FMM panel is in the “ON/OPEN” position.
4. Start and run the engine until it stops.
5. Ensure the vehicle is off and that the proper vehicle lock-out procedures are followed. (Remove the ignition key).
6. Check the gauges on the fill panel to ensure that all the pressure is relieved.
7. Remove the access cover on the rear of the fill panel (if equipped).
8. Relieve the remaining pressure by slowly opening the bleed valve inside or near the FMM.
9. The system is now fully depressurized up to the primary solenoid lock-off valve. There may be pressure remaining downstream of the solenoid valve. Be careful when loosening fittings for the first time because a small amount of gas may leak out of any fitting downstream of the solenoid lock-off valve, which is normal.

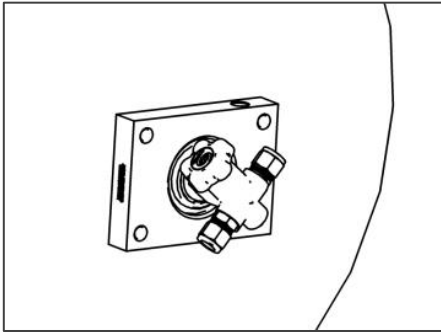

Figure 3 Cylinder manual shutoff valves are mounted on one end of each fuel cylinder.

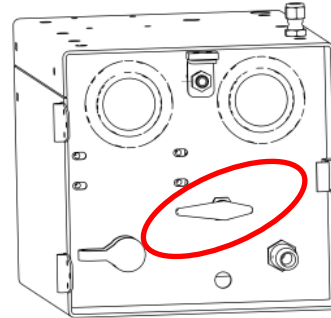

Figure 4 The manual shutoff valve on the FMM panel must be OPEN when depressurizing the system.

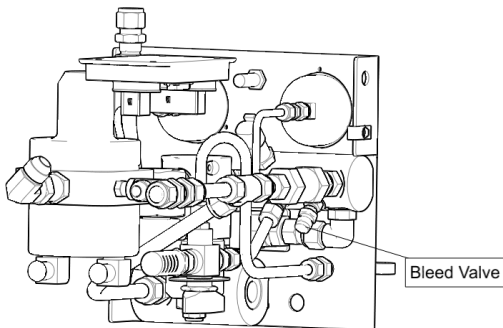

Figure 5 Use the bleed valve inside the FMM to release the remaining pressure in the system.



Figure 6 Lock-out the system as per your facility safety policies require. Removing the vehicle ignition key can be used to lock-out the fuel system.

5. Defuel the System

Defueling a CNG fuel system requires careful planning, since the vehicle must be towed, rather than driven to be moved***. It is usually best to drive the vehicle to near-empty to minimize the amount of fuel to be vented to the atmosphere.

***NOTE

An Agility Fuel Systems Pony Tank may be used to supply fuel a vehicle temporarily so it may be driven. See References section.

5.1 Defueling Preparation and Procedures

The best and safest way to defuel a CNG system is to transfer fuel back to a dispensing station, if

so equipped. Check with your CNG filling station for specific procedures. The following information is provided in the absence of formalized procedures from local authorities. A typical venting facility diagram is shown in Figure 7.



WARNING

Be sure to vent a CNG tank in an open area with good air circulation with no nearby sources of open flame, ignition or heat. Do not vent the system in an area where flammable gas is permitted to accumulate and potentially ignite.

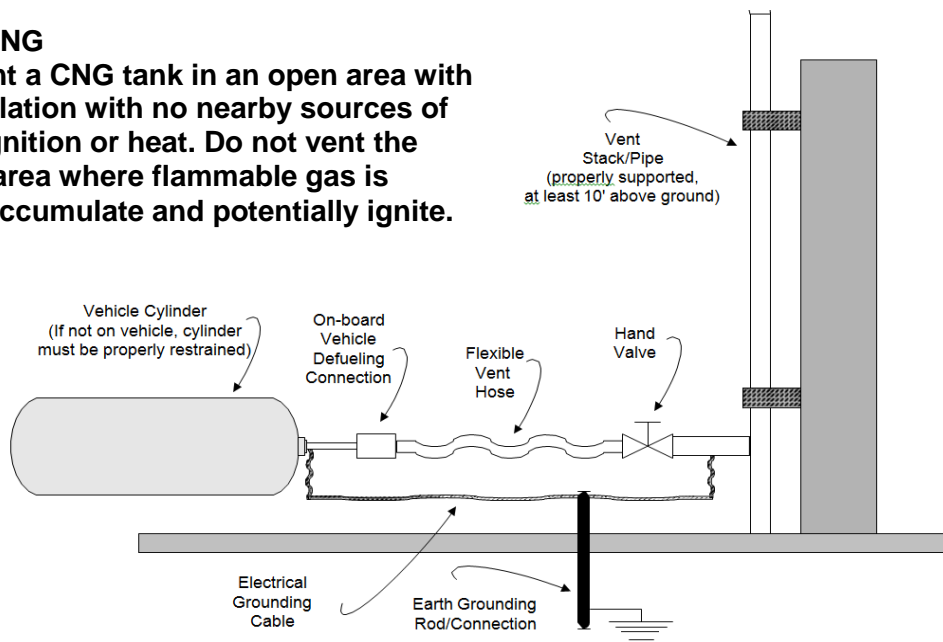

Figure 7 Typical venting facilities include all of these features.

A venting facility should include the minimum equipment:

A vent pipe. This typically consists of a two-inch diameter steel pipe attached to a support structure. The pipe must extend a minimum of two feet higher than the support structure and at least 10 feet above ground level. The vent pipe must be connected to an electrical ground. There should be no ignition sources near the pipe.

An electrical ground connection with a minimum 3 gauge or heavier stranded copper wire attached to a ground rod, or a suitable electrical ground. Other items to include:

- A high pressure electrically conductive flexible hose.
- A hand valve to control the flow of gas.
- A fire extinguisher. The extinguisher should have a rating no less than 20-B:C.
- Large signage indicating “NO SMOKING” and “FLAMMABLE GAS.”

5.2 Defueling Options

There are three common defueling options: Vent to atmosphere, compressor transfer and return to supply. In all cases, both vehicle and the fueling system must be grounded to prevent static electricity build-up.

(a) Vent to Atmosphere

First, verify whether or not this method is legal. There may be local air quality regulations restricting the release of methane into the atmosphere. If atmospheric venting is acceptable in your area, then a venting facility compliant to regulations must be used.

(b) Compressor Transfer

In this defueling method, a compressor at the fueling station extracts the gas from vehicle.

(c) Returning to Supply

The third method returns fuel to a distribution system. When using this process, pressure in the vehicle cylinder and the supply system pressure will equalize, so some pressure may remain in the vehicle fuel system.

5.3 General Defueling Procedure

NOTE

This procedure applies to vehicles equipped with a NGV1-style defuel receptacle.

1. Connect the ground wire from the vehicle to the vent stack system.
2. Attach the defuel hose (see Figure 8) to the vent stack system.
3. Attach the defuel nozzle to the defuel receptacle on the FMM.
4. Ensure the manual shutoff valve is OPEN.
5. Slowly open the defuel valve, and adjust for a slow and steady flow to avoid freeze-up.

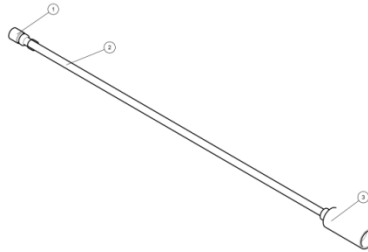

Figure 8 Agility Fuel Systems 20100021 fuel transfer hose.

6. Attachment

- CNG Pressure Zones

7. References

- Agility Fuel Systems Pony Tank Operation Manual, ENP-005
- Agility Fuel Systems Pony Pallet Operation Manual, ENP-372
- Agility Fuel Systems Type 2 Pony Tank Operation Manual, ENP-249
- Agility Fuel Systems Truck and Tractor CNG Fuel System Operation Manual, ENP-007
- Agility Fuel Systems CNG System Users' Manual, ENP-314
- Agility Fuel Systems Field Service Bulletin, Service Facility Fuel Handling Equipment, ENP-380

8. Warranty Statement

Does not apply.

Contact Agility Fuel Systems Product Support at 949-267-7745 or support@agilityfs.com for more information.

Proprietary Statement

The information provided within this document is proprietary and confidential. All prior versions of this document, including updates and revisions forwarded separately, are proprietary. The information provided by Agility Fuel Systems to its customers and clients is solely for the use of those customers and clients. No portion of this manual may be reproduced or distributed without express written consent of Agility Fuel Systems. Agility Fuel Systems reserves the right to utilize the intellectual property contained within this publication as content for any other publication produced by Agility Fuel Systems.

Revision	Description	Author	Approved By	Date
--	Initial Release	W. Yoshida	Y. Coy	5/8/15

CNG Pressure Zones

Cannot Isolate Pressure:
MUST DEFUEL

Items in RED Always Under Pressure

- Cylinders
- Manual Valves
- PRDs
- PRD Lines

Blue Fuel Lines can be isolated w/cylinder valve

High Pressure up to 4,500 psi

Can Isolate Pressure:
DEPRESSURIZE

- Ball Valve
- Filter
- Solenoid Valve
- Regulator

Can Isolate Pressure:
DEPRESSURIZE

Low Pressure Filter

Low Pressure to Engine 125 to 135 psi

