

TECHNICAL BULLETIN
LTB00695NAS1
21 OCT 2014



© Jaguar Land Rover North America, LLC

NOTE: The information in Technical Bulletins is intended for use by trained, professional Technicians with the knowledge, tools, and equipment required to do the job properly and safely. It informs these Technicians of conditions that may occur on some vehicles, or provides information that could assist in proper vehicle service. The procedures should not be performed by 'do-it-yourselfers'. If you are not a Retailer, do not assume that a condition described affects your vehicle. Contact an authorized Land Rover service facility to determine whether this bulletin applies to a specific vehicle.

SECTION: 205-00

Vibration in 7th/8th Gear at High Speed

AFFECTED VEHICLE RANGE:

Range Rover Sport (LW)

Model Year: 2014

VIN: EA000001-EA371201

MARKETS:

NAS

CONDITION SUMMARY:

Situation: A driveline vibration, felt through the floor and/or seat only, may be evident with the transmission in 7th/8th gear at vehicle speeds above 100kph/62mph while on overrun and/or light throttle.

Cause: This may be caused by 'forcing' (eccentricity between the driveshaft and differential at the coupling) from the front and/or rear driveline.

Action: Should a customer express this concern, follow the Service Instruction outlined below.

PARTS:



NOTE: An allowance equivalent £10.00 has been allocated for the cost of the locally sourced Loctite 648 and must be claimed using 'ZZZ001'.

TYG500141	Front driveshaft bolts	Quantity: 6
TYG500130	Rear driveshaft bolts	Quantity: 4
LR057620	Front driveshaft (only required if Service Instruction 'B' is necessary)	Quantity: 1
LR066508	Front differential 3.0L SC V6	Quantity: 1
LR066510	Front differential 5.0L SC V8	Quantity: 1
TYK500010	Differential oil (only required if front differential is replaced)	Quantity: 1
LR026275	Nut (only required if front differential is replaced)	Quantity: 2
KYG000230	Bolt (only required if front differential is replaced)	Quantity: 2
FY110056	Nut (only required if front differential is replaced)	Quantity: 2
LR024151	Halfshaft nut (only required if front differential is replaced)	Quantity: 2
QYG500090	Bolt - LHD vehicles only (only required if front differential is replaced)	Quantity: 1
LR038977	Bolt (only required if front differential is replaced)	Quantity: 1

TOOLS:

Mounting bracket
100-053

WARRANTY:

 **NOTE: An allowance equivalent £10.00 has been allocated for the cost of the locally sourced Loctite 648 and must be claimed using 'ZZZ001'.**

 **NOTE: Repair procedures are under constant review, and therefore times are subject to change; those quoted here must be taken as guidance only. Always refer to TOPIx to obtain the latest repair time.**

 **NOTE: DDW requires the use of causal part numbers. Labor only claims must show the causal part number with a quantity of zero.**

DESCRIPTION	SRO	TIME (HOURS)	CONDITION CODE	CAUSAL PART
Measurement and/or adjustment of driveshafts with a Dial Test Indicator	05.10.90	0.9	42	LR034513
Driveshaft - Front - Renew	47.15.02	1.2	42	LR034513
Driveshaft - Rear - Renew	47.15.03	2.3	42	LR034513
Differential - Front - Renew	54.10.01	4.7	42	LR034513

 **NOTE: Normal Warranty procedures apply.**

SERVICE INSTRUCTION 'A'

 **NOTE: If the customer concern / vibration is felt through the steering wheel, investigate and rectify this first; must be performed as a separate claim.**

Steps 1-15: Front Driveshaft Measurement

1. Remove the engine undershield (see TOPIx Workshop Manual, section 501-02).
2. Remove heat shield retaining bolt.

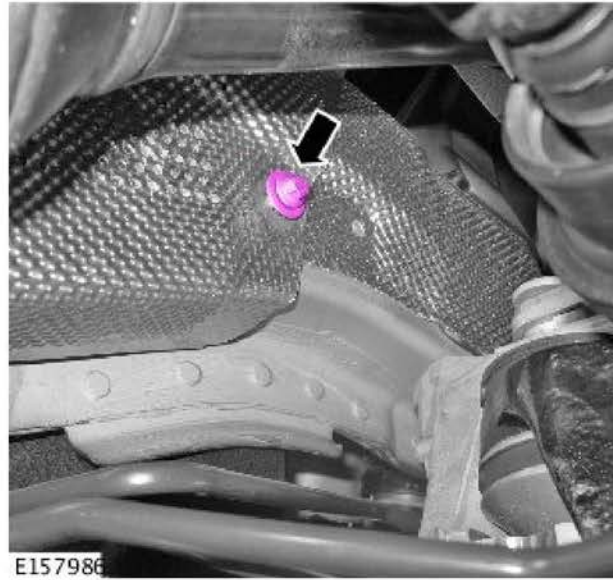

3. Install the mounting bracket and Dial Test Indicator (DTI).



4. Position dial gauge pointer so that it is touching the surface of the inner front driveshaft coupling.



5. Hold one of the front wheels in position and rotate the other to measure the Total Indicator Reading (TIR) of the joint head.

- Record the TIR value.



6. Mark the front driveshaft joint head relative to the axle for installation purposes.

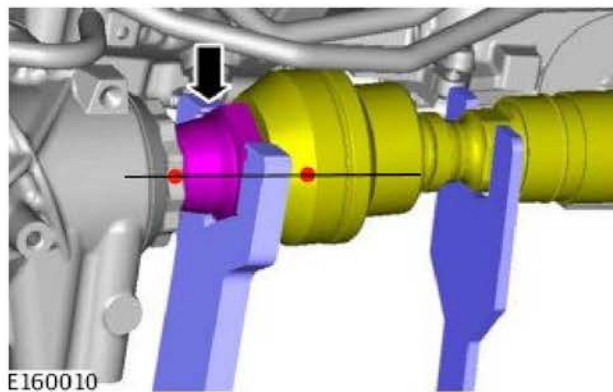

7. Remove the front driveshaft (see TOPIX, Workshop Manual, section 205-01).

8.  **NOTE: The fitted pinion type will affect the action required during Service Instruction 'B'.**

Identify the currently fitted front differential pinion type:

- (1) Old type
- (2) Modified type

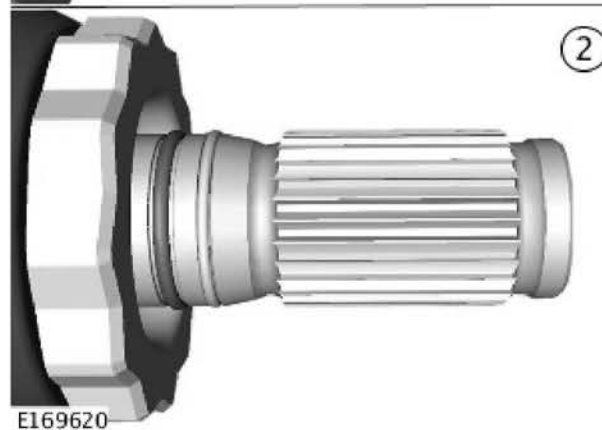
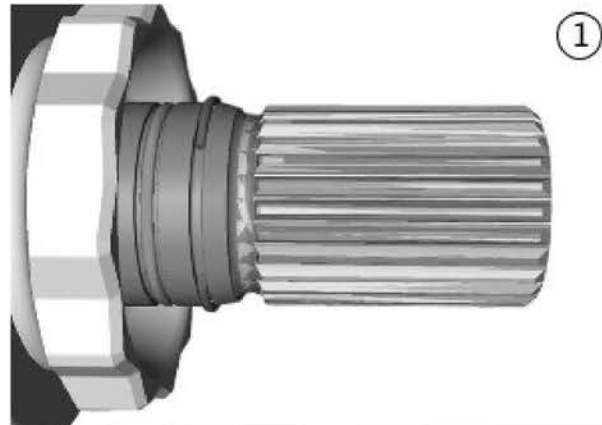

E169620

9. Clean 15mm of spline at the end of the axle pinion.

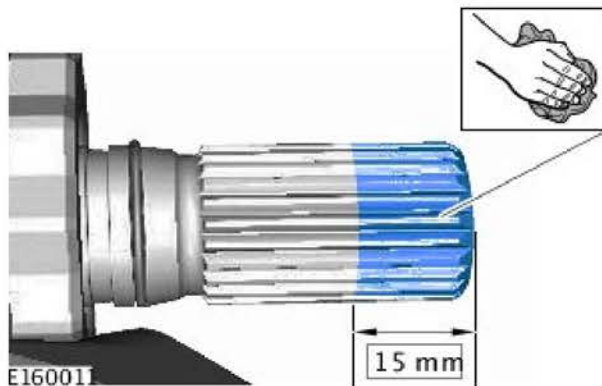

E160011

10. Apply Loctite 648 to a length of 15mm at the end of the axle pinion.

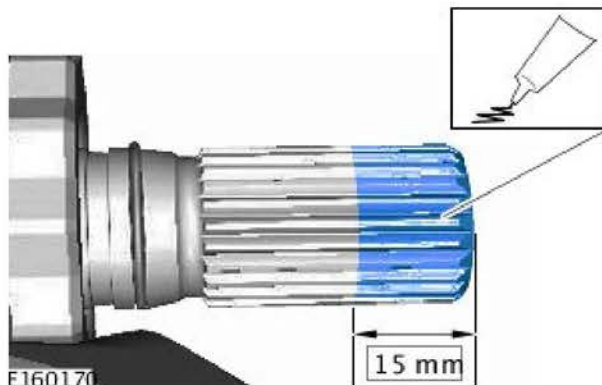

E160170

11. Install the driveshaft with the ID marks 180 degrees opposed.

- Tighten driveshaft nut by hand.

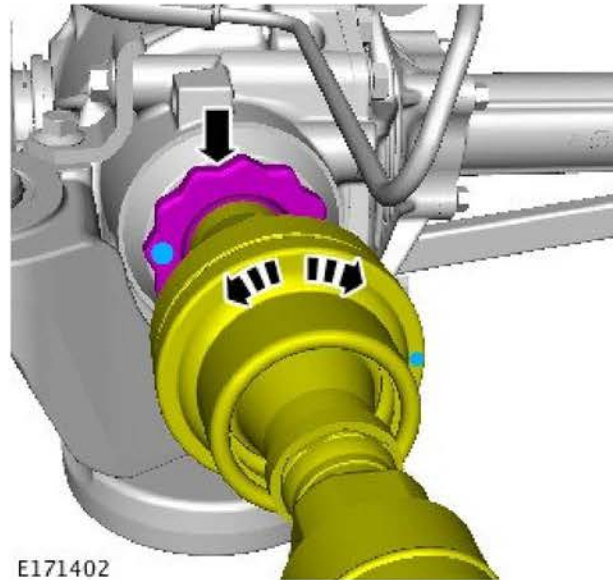

12.  **NOTE: The joint may require adjustment by tapping it lightly with a copper hammer to centralize and to bring Total Indicator Reading (TIR) within specification.**

Repeat Step 5, making adjustments as necessary, until Total Indicator Reading (TIR) is as close to zero as possible (must be less than 0.15mm TIR).

- 13.** Leave for 45 minutes to allow the Loctite to cure.
- 14.** Tighten driveshaft nut (see TOPIx Workshop Manual, section 205-01).
- 15.** Remove DTI gauge.
- 16.** Install the engine undershield (see TOPIx Workshop Manual, section 501-02).

Steps 16-26: Rear Driveshaft Measurement

17. Install a suitable mounting bracket and Dial Test Indicator (DTI).

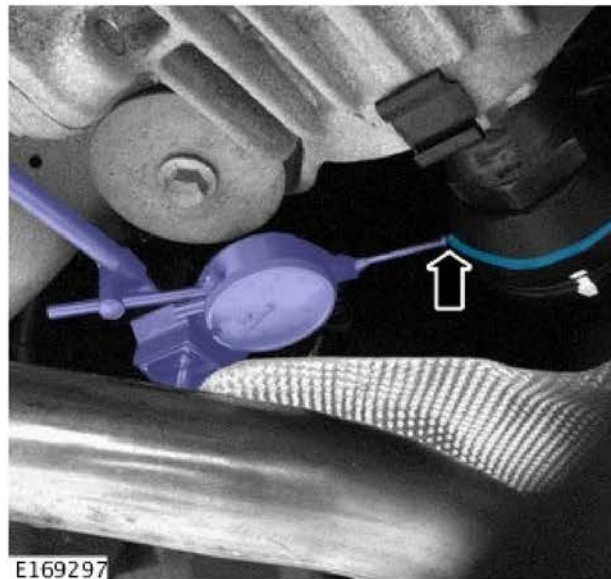

18.  **NOTE: Front differential shown; rear similar.**

Hold one of the rear wheels in position and rotate the other to measure the Total Indicator Reading (TIR) of the joint head.

- Record the TIR value.



19.  **NOTE: Make sure position of driveshaft joint is marked relative to the axle**

Remove the rear driveshaft (see TOPIX Workshop Manual, section 205-01).

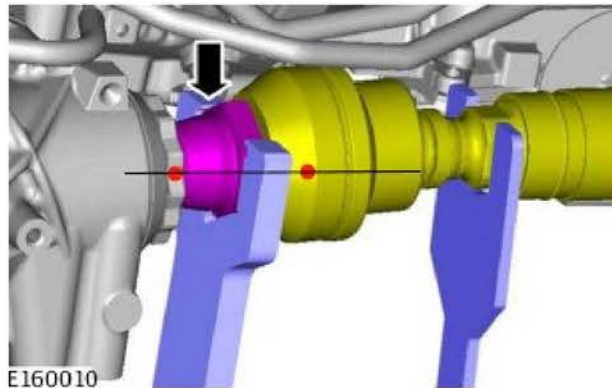

20. Clean 15mm of spline at the end of the axle pinion.

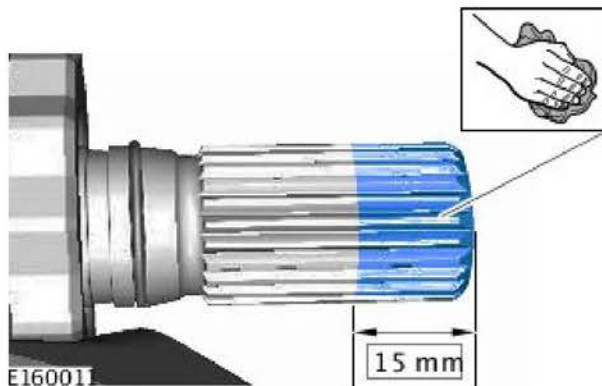

21. Apply Loctite 648 to a length of 15mm at the end of the axle pinion.

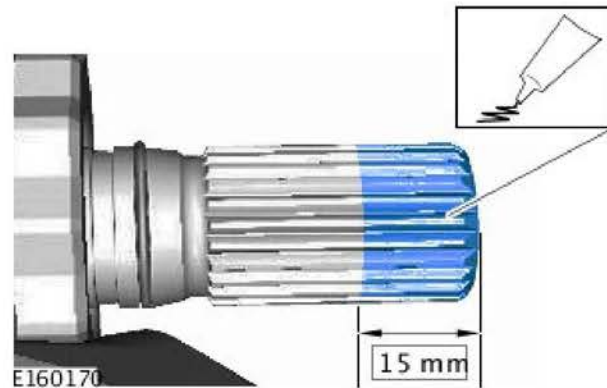

22.  **NOTE: Front differential shown; rear differential similar.**

Install the driveshaft with the ID marks 180 degrees opposed.

- Tighten driveshaft nut by hand.

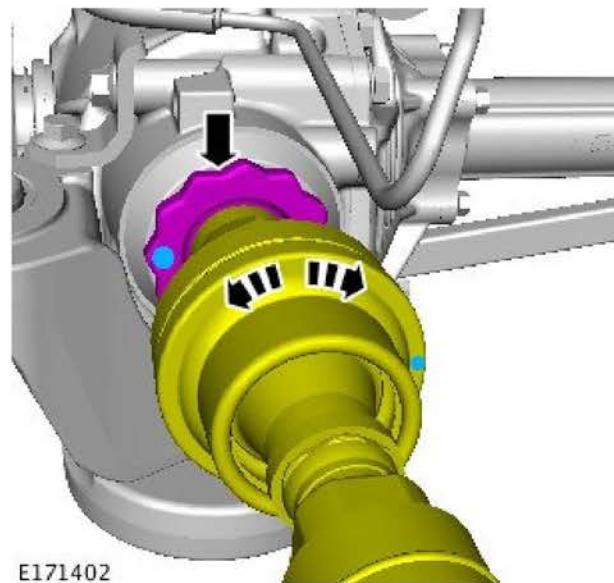

23.  **NOTE: The joint may require adjustment by tapping it lightly with a copper hammer to centralize and to bring Total Indicator Reading (TIR) within specification.**

Repeat Step 18, making adjustments as necessary, until TIR is as close to zero as possible (must be less than 0.15mm TIR).

24. Leave for 45 minutes to allow the Loctite to cure.
25. Tighten driveshaft nut (see TOPIX Workshop Manual, section 205-01).
26. Remove DTI gauge.
27. Retest vehicle:
- If the vibration is not evident, reverse steps 1-2 and release vehicle to customer.
 - If the vibration is still evident, continue to Service Instruction B.

SERVICE INSTRUCTION 'B'

Front Differential Pinion Identification; Front Differential / Driveshaft Replacement

1.  **NOTE: Vehicles already fitted with the**

modified front differential (2) do NOT require the front differential to be replaced.

As identified in Service Instruction 'A', step 8:

- (1) 'Old' type
 - If the vehicle is fitted with the 'Old' type (1) front differential pinion, continue to step 2.
- (2) 'Modified' type
 - If the vehicle is fitted with the 'Modified' type (2), continue to step 3.

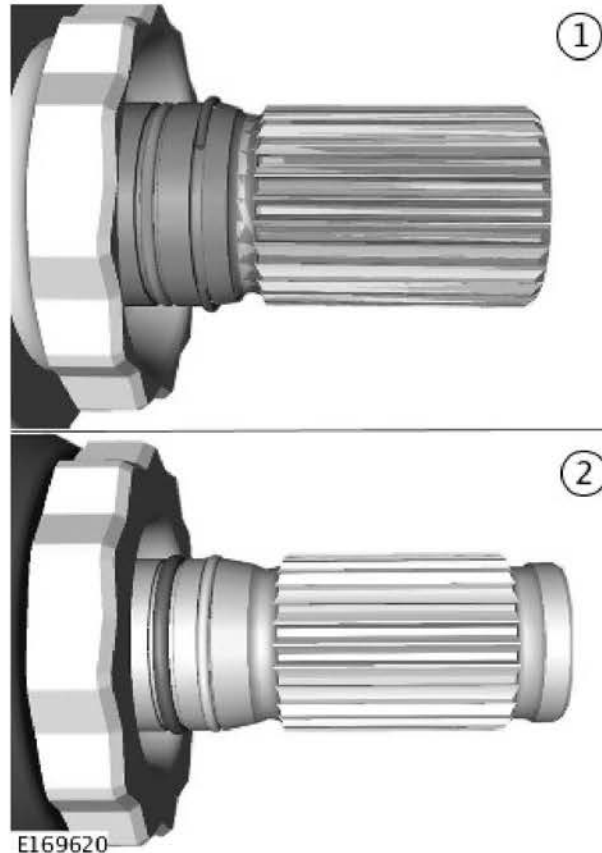

2.  NOTE: Loctite is not required on latest level parts

If vibration still present after performing Service Instruction 'A' and the vehicle is fitted with the 'Old' type (1) front differential, replace the front differential and the front driveshaft with the latest production parts to reduce eccentricity at coupling (see TOPIX Workshop Manual, section 205-03).

3.  NOTE: Loctite is not required on latest level parts

If vibration still present after performing Service Instruction 'A' and the vehicle is fitted with the 'New' type (2) front differential, replace only the front driveshaft with the latest production parts to reduce eccentricity at coupling (see TOPIX Workshop Manual, section 205-03).