

Subject: SPECIAL SERVICE TOOL SHIPMENT - OCTOBER 2014	Bulletin No: 00-003/14
	Last Issued: 10/15/2014

APPLICABLE MODEL(S)/VINS

- 2013-15 CX-5 (with manual transmission)
- 2012-15 Mazda3 SKYACTIV (with manual transmission)
- 2014-15 Mazda6 (with manual transmission)

DESCRIPTION/PRICING

In support of SKYACTIV Manual Transmission models, Mazda will ship to all dealers one (1) new Special Service Tool (SST). The SST will be shipped automatically by Mazda's tool vendor Snap-On Tools, starting in mid-October 2014.

The following SST is the latest addition to the Mazda Required Tool (MRT) list.

Part Number	Description	Pricing
4907-10-520A	Bearing Puller	\$107.10

BILLING INFORMATION

Tool(s) will be automatically invoiced to your dealer parts account statement. If your accounting department has any questions regarding this invoicing, please call Mazda Special Service Tools (949-442-6539).

SHIPPING INFORMATION

Tools will be shipped via UPS Ground to your service department by mid-October 2014.

Please advise your shipping/receiving personnel of this tool shipment.

OBTAINING ADDITIONAL TOOLS

To order additional SSTs, submit orders via MStore at <http://dealers.mazdausa.com>.

CUSTOMER SERVICE INFORMATION

For warranty or product information call Snap-On Customer Service at (800) 424-7226.

CONSUMER NOTICE: The information and instructions in this bulletin are intended for use by skilled technicians. Mazda technicians utilize the proper tools/equipment and take training to correctly and safely maintain Mazda vehicles. These instructions should not be performed by "do-it-yourselfers." Customers should not assume this bulletin applies to their vehicle or that their vehicle will develop the described concern. To determine if the information applies, customers should contact their nearest authorized Mazda dealership. Mazda North American Operations reserves the right to alter the specifications and contents of this bulletin without obligation or advance notice. All rights reserved. No part of this bulletin may be reproduced in any form or by any means, electronic or mechanical---including photocopying and recording and the use of any kind of information storage and retrieval system ---without permission in writing.

SPECIAL SERVICE TOOL (SST) AND USAGE

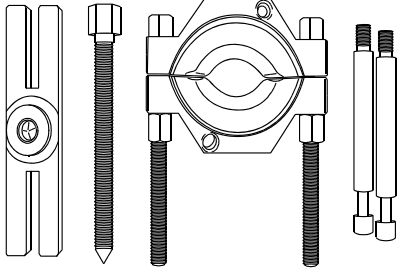
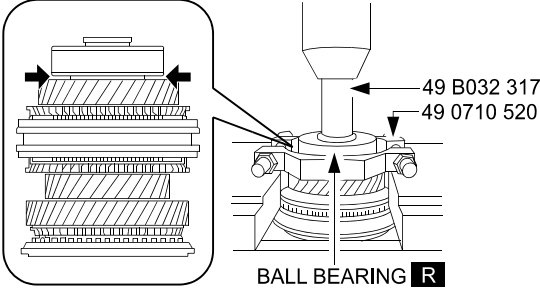
PART NUMBER / NAME:	OVERVIEW	USAGE
<p>4907-10-520A Bearing Puller</p> <p>APPLICABLE MODELS: All SKYACTIV vehicles with manual transmission</p> <p>USAGE: To remove the primary shaft ball bearing for access to the 3GR/4GR Clutch Hub.</p>	 <p>4907-10-520A BEARING PULLER</p>	<p>Utilize w/the 3rd GR/4th GR clutch hub removal procedure in the Workshop Manual – Manual Transmission Section.</p>  <p>49 B032 317 49 0710 520</p> <p>BALL BEARING R</p>