

© 2014 Mazda Motor of America, Inc.

Subject: CRACKING NOISE FROM WINDSHIELD AND/OR REAR WINDOW	Bulletin No: 09-025/14
	Last Issued: 09/03/2014

BULLETIN NOTE

- This bulletin supersedes the previous bulletin 09-025/14, issued on 05/29/2014. The APPLICABLE MODEL(S)/VINS, REPAIR PROCEDURE, and WARRANTY INFORMATION have been revised.
- Changes are noted below in Red beside the change bar.

APPLICABLE MODEL(S)/VINS

2010-2013 Mazda3 (including Mazdaspeed3)

2014 Mazda6 vehicles with VINs lower than:

- Windshield - JM1 GJ ***** 125986 (produced before June 03, 2013)
- Rear Window - JM1 GJ ***** 137237 (produced before August 01, 2013)

2013-2014 CX-5 vehicles with VINs lower than JM3 KE ***** 398378 (produced before October 01, 2013)

DESCRIPTION

Some vehicles may exhibit a cracking noise originated at the positioning pins near the top corners of the windshield and/or rear window when driving on uneven road surface. This happens when the ambient temperature is approximately 14 °F (-10 °C) or lower and the vehicle cabin has not yet warmed up. The noise is caused by the windshield and/or rear window locating stopper contacting the panel.

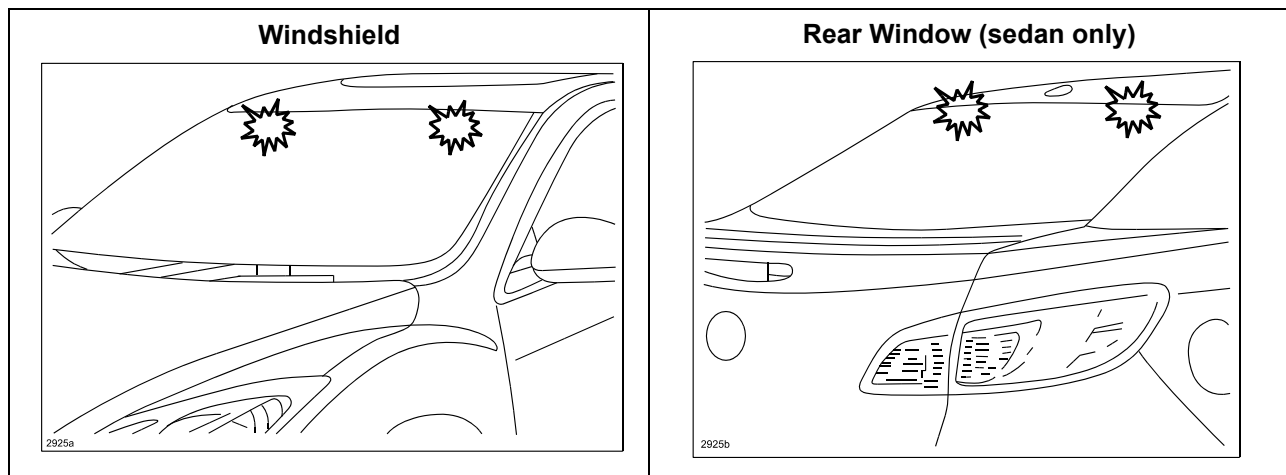

Customers having this concern should have their vehicle repaired using the following repair procedure.

REPAIR PROCEDURE

1. Verify customer concern.
2. Cut the end of the stopper and bend the panel at the affected windshield and/or rear window.

Windshield:

- a. Remove the assist handle. Refer to MS3 online or the Workshop Manual section 09-17:
 - Mazda3 - ASSIST HANDLE REMOVAL/INSTALLATION
 - Mazda6 - ASSIST HANDLE REMOVAL/INSTALLATION
 - CX-5 - ASSIST HANDLE REMOVAL/INSTALLATION
- b. Remove the sunvisor. Refer to MS3 online or the Workshop Manual section 09-17:
 - Mazda3 - SUNVISOR REMOVAL/INSTALLATION
 - Mazda6 - SUNVISOR REMOVAL/INSTALLATION
 - CX-5 - SUNVISOR REMOVAL/INSTALLATION
- c. Partially peel back the seaming welt.
- d. Separate the A-pillar trim from the A-pillar. Refer to MS3 online or Workshop Manual section 09-17:
 - Mazda3 - A-PILLAR TRIM REMOVAL/INSTALLATION
 - Mazda6 - A-PILLAR TRIM REMOVAL/INSTALLATION
 - CX-5 - A-PILLAR TRIM REMOVAL/INSTALLATION
- e. Attach masking tape (A) to the black portion of the windshield around the area you are working in to prevent scratches.

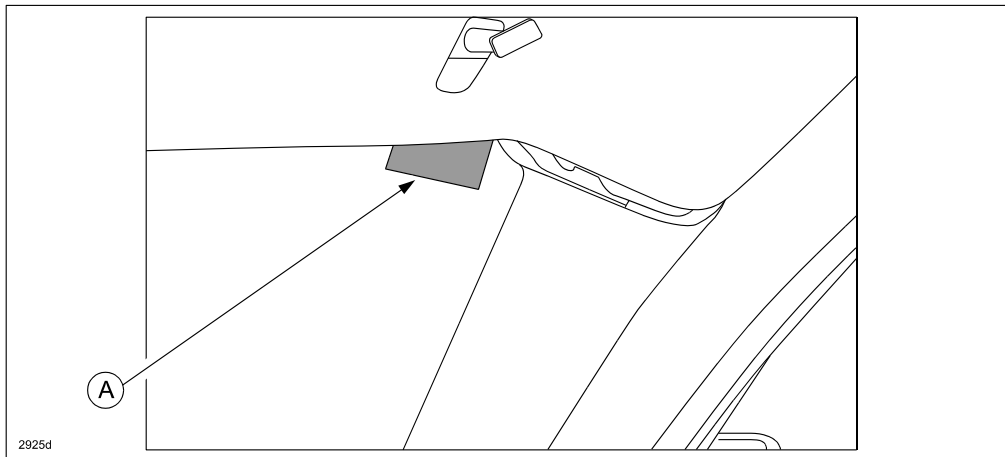

- f. Gently pull down on the headliner to provide enough space to insert the side cutters.

- g. Insert the side cutters between the headliner and the reinforcement panel (A), and cut the end of the pin (B).

CAUTION: DO NOT apply excessive force to the pin, or the windshield may crack.

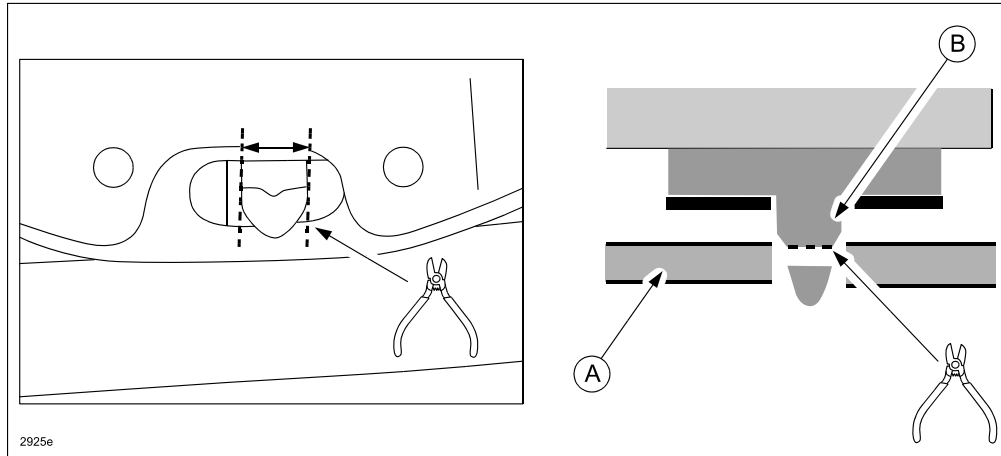

- h. Pull down the reinforcement panel by the masking tape (A) using a suitable tool (B), such as a retaining clip remover, to provide clearance between the reinforcement panel and the remainder of the cut pin. Make sure there is no remaining contact between the pin and the reinforcement panel.

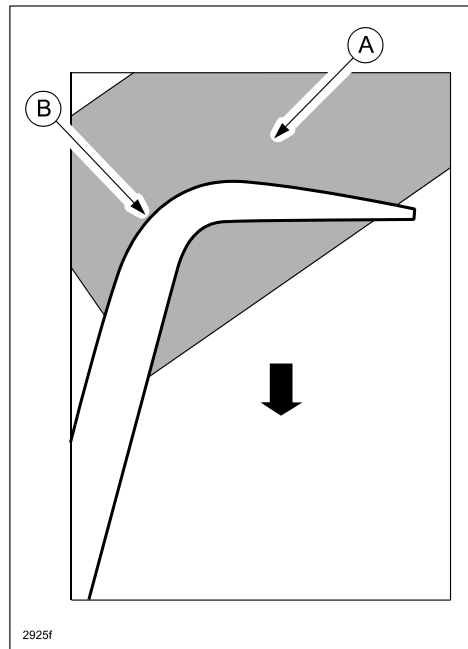

- i. Repeat on the other side and reassemble the removed components in the reverse order of removal.

Rear Window (Mazda6 and Mazda3 sedan only):

- a. Remove the C-pillar trim. Refer to MS3 online or the Workshop Manual (section 09-17:

- Mazda3 - C-PILLAR TRIM REMOVAL/INSTALLATION
- Mazda6 - C-PILLAR TRIM REMOVAL/INSTALLATION

NOTE: Follow the instructions and be careful not to damage the clips. Clip B is a replacement part.

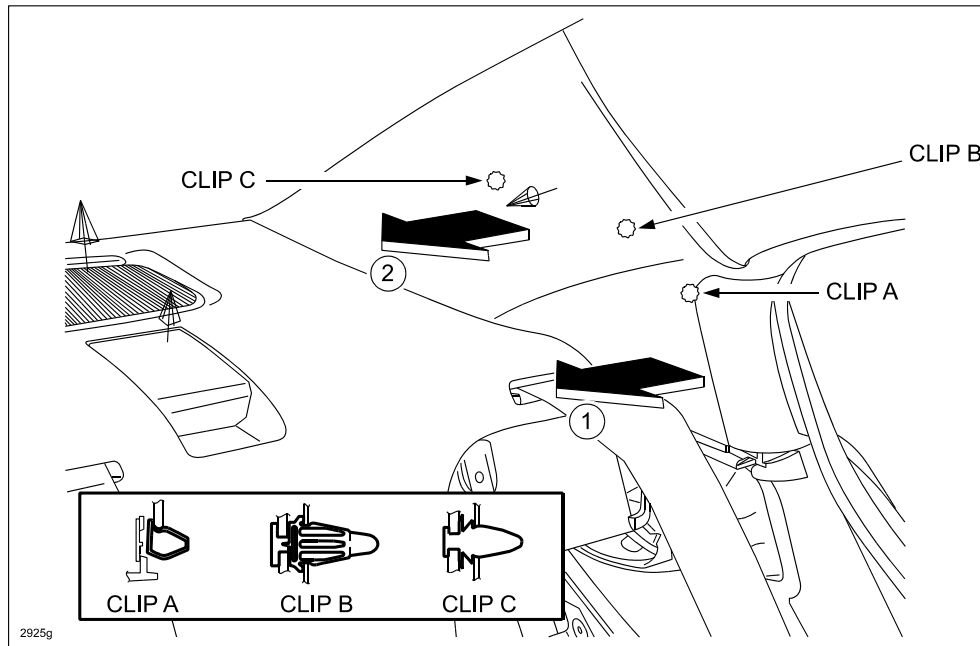

- b. Remove the clips (A) securing the headliner to the roof panel.

NOTE: Take care when handling the headliner to prevent getting dirt or grease on it.

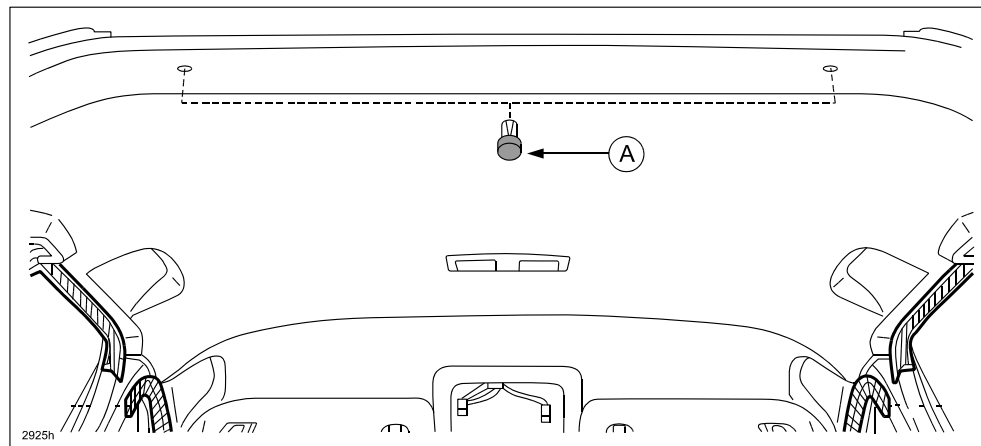

- c. Attach masking tape to the black portion of the rear window around the area you are working to prevent scratches.
- d. Gently pull down the headliner to provide enough space to insert side cutters.

- e. Insert the side cutters between the headliner and the reinforcement panel (A), and cut the end of the pin (B).

CAUTION: DO NOT apply excessive force to the pin, or the windshield may crack.

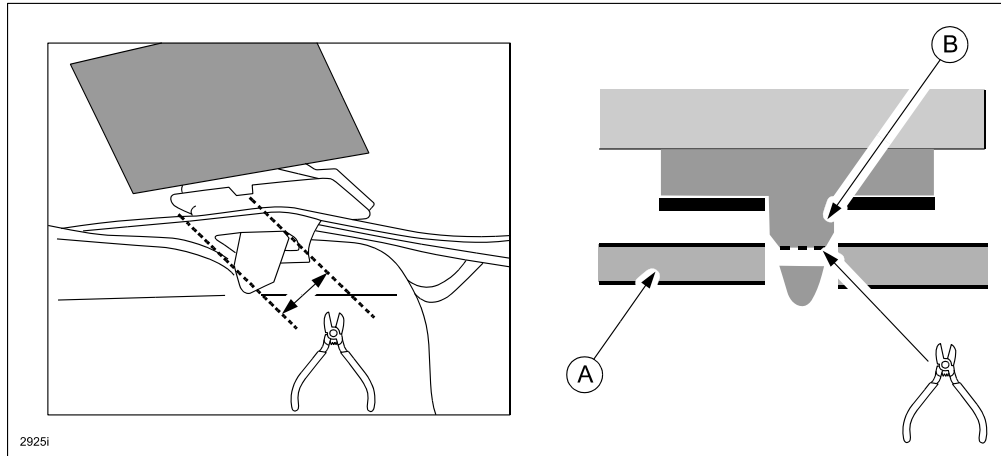

- f. Pull down the reinforcement panel by the masking tape (A) using a suitable tool (B), such as a retaining clip remover, to provide clearance between the reinforcement panel and the remainder of the cut pin. Make sure there is no remaining contact between the pin and the reinforcement panel.

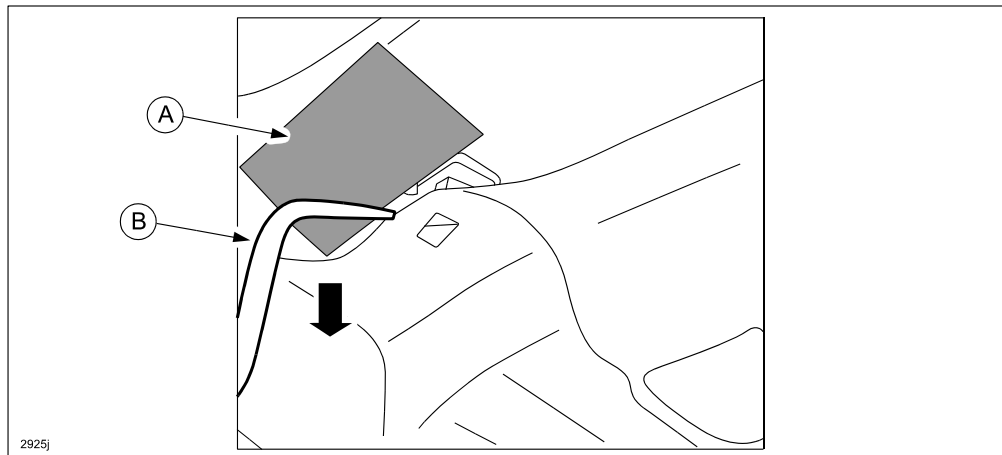

- g. Repeat on the other side and reassemble the removed components in the reverse order of removal.
3. Verify repair.

PART(S) INFORMATION

Part Number	Description	Qty.	Notes
D651-68-162A	Clip	4	2 for A-Pillar 2 for C-Pillar

WARRANTY INFORMATION

NOTE:

- This warranty information applies only to verified customer complaints on vehicles eligible for warranty repair.
- This repair will be covered under Mazda's New Vehicle Limited Warranty.
- Additional diagnostic time cannot be claimed for this repair.

Windshield:	Mazda3, Mazda6, CX-5
Warranty Type	A
Symptom Code	82
Damage Code	97
Part Number Main Cause	7777-SP-J60
Quantity	0
Operation Number / Labor Hours:	XXK7DARX / 0.3 Hrs.

Rear Window (sedan only):	Mazda3	Mazda6
Warranty Type	A	A
Symptom Code	82	82
Damage Code	97	97
Part Number Main Cause	7777-SP-J60	7777-SP-J60
Quantity	0	0
Operation Number / Labor Hours:	XXK7DBRX / 0.6 Hrs.	XXK7DBRX / 0.4 Hrs.

Windshield and Rear Window (sedan only):	Mazda3	Mazda6
Warranty Type	A	A
Symptom Code	82	82
Damage Code	97	97
Part Number Main Cause	7777-SP-J60	7777-SP-J60
Quantity	0	0
Operation Number / Labor Hours:	XXK7DCRX / 0.8 Hrs.	XXK7DCRX / 0.6 Hrs.