

© 2014 Mazda Motor of America, Inc.

Subject: A/C MODE SELECTOR DIAL DOES NOT STAY IN "DEFROSTER VENTS" POSITION - (MANUAL A/C ONLY)	Bulletin No: 07-001/14
	Last Issued: 07/08/2014

APPLICABLE MODEL(S)/VINS

2013-2015 CX-5 vehicles equipped with manual type air conditioning system with VINs lower than JM3KE*****488298 (produced before June 1, 2014)

DESCRIPTION

When selecting the "Defroster Vents" position (B) with the Mode Selector Dial (A), some customers may notice the dial does not stay in the "Defroster Vents" position and returns to the "Defroster/Floor Vents" position (C).

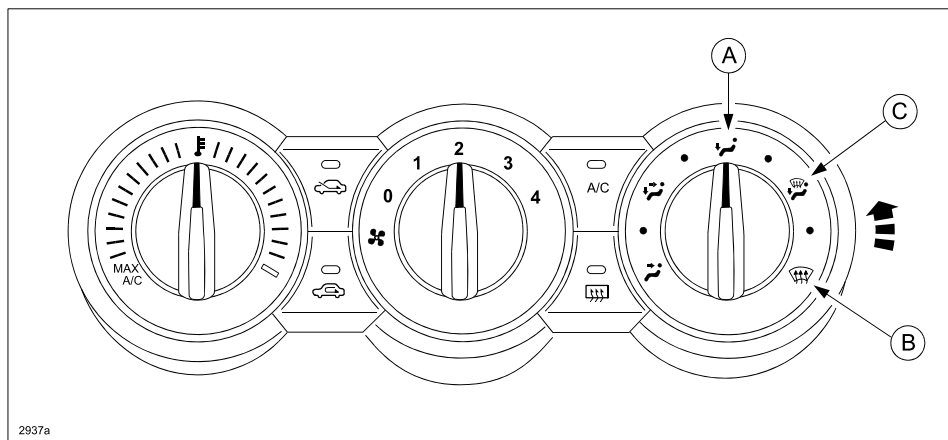

This concern may be due to a production variation. Some of the mode control wires (A) may be too long to transmit movement from the mode selector dial to the link (B). The length of the mode control wire has been shortened to eliminate this concern.

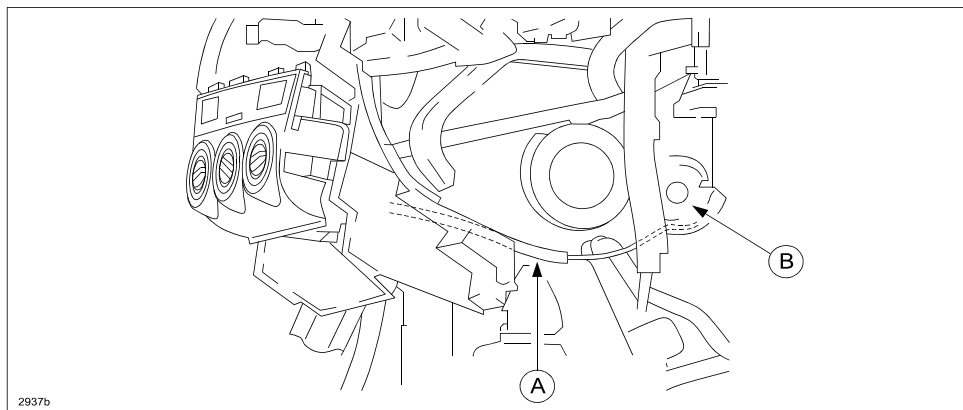

Customers having this concern should have their vehicle repaired using the following repair procedure.

CONSUMER NOTICE: The information and instructions in this bulletin are intended for use by skilled technicians. Mazda technicians utilize the proper tools/equipment and take training to correctly and safely maintain Mazda vehicles. These instructions should not be performed by "do-it-yourselfers." Customers should not assume this bulletin applies to their vehicle or that their vehicle will develop the described concern. To determine if the information applies, customers should contact their nearest authorized Mazda dealership. Mazda North American Operations reserves the right to alter the specifications and contents of this bulletin without obligation or advance notice. All rights reserved. No part of this bulletin may be reproduced in any form or by any means, electronic or mechanical---including photocopying and recording and the use of any kind of information storage and retrieval system ---without permission in writing.

REPAIR PROCEDURE

1. Replace the mode control wire with a modified one according to the instructions on MS3 online or the Workshop Manual (section 07-40 CLIMATE CONTROL UNIT REMOVAL/INSTALLATION [MANUAL AIR CONDITIONER])
2. Verify the repair.

PART(S) INFORMATION

Part Number	Description	Qty.	Notes
KD45-61-C35A	Mode Control Wire	1	Manual A/C System

WARRANTY INFORMATION

NOTE:

- This warranty information applies only to verified customer complaints on vehicles eligible for warranty repair.
- This repair will be covered under Mazda's New Vehicle Limited Warranty term.
- Additional diagnostic time cannot be claimed for this repair.

Warranty Type	A
Symptom Code	43
Damage Code	97
Part Number Main Cause	KD45-61-C35A
Quantity	1
Operation Number / Labor Hours:	XXK5HXRX / 0.6 Hrs.