

<b>Subject:</b> <b>CHECK ENGINE LIGHT ON WITH DTC P0452:00 AND/OR P0453:00</b>	<b>Bulletin No:</b> 01-008/14
	<b>Last Issued:</b> 04/01/2014

## APPLICABLE MODEL(S)/VINS

2013-2015 CX-5 with VINs lower than JM3KE\*\*\*\*\*438362 (produced before Jan. 27, 2014)

## DESCRIPTION

Some vehicles may exhibit a condition where the Check Engine Light illuminates immediately after the engine is started and DTC P0452:00 and/or P0453:00 is stored in memory.

- P0452:00 - Fuel tank pressure sensor low input
- P0453:00 - Fuel tank pressure sensor high input

This concern may be caused by ants entering the FTP sensor through an opening (to atmosphere). The ants bite and eventually damage the wiring, which results in an improper FTP sensor output.

To eliminate this concern, the inside of the opening pipe (to atmosphere) has been modified to prevent ants from entering.

Customers having this concern should have their vehicle repaired using the following repair procedure.

## REPAIR PROCEDURE

1. Verify the customer concern.
2. Replace the charcoal canister assembly (includes FTP sensor) with a modified part according to the instructions on MS3 online or the Workshop Manual (section 01-16 CHARCOAL CANISTER REMOVAL/INSTALLATION [SKYACTIV-G 2.0, SKYACTIV-G 2.5]).

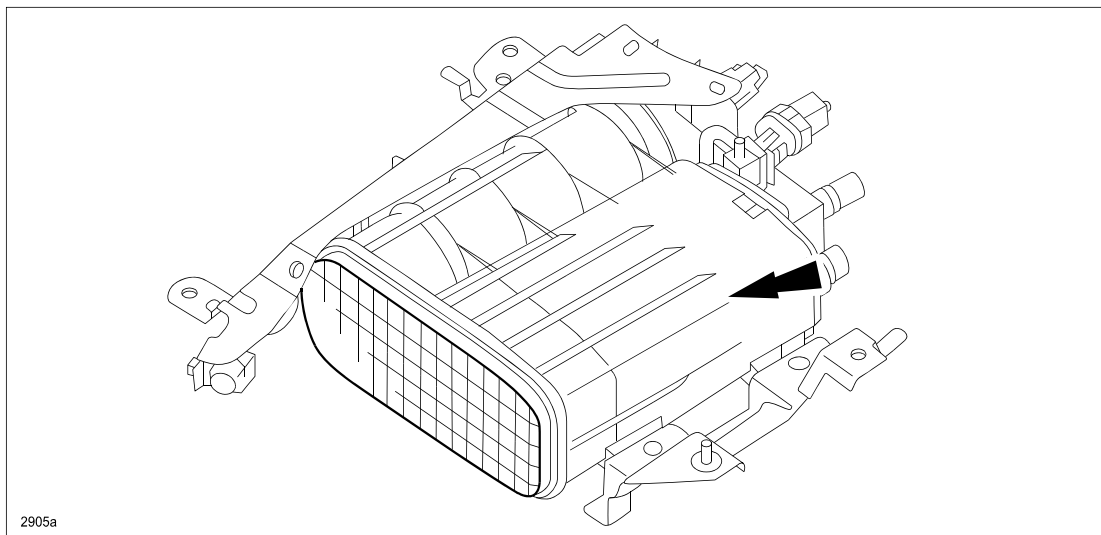

3. Verify the repair.

**Bulletin No:** 01-008/14  
© 2014 Mazda Motor of America, Inc.

**Last Issued:** 04/01/2014

## PART(S) INFORMATION

Part Number	Description	Qty.	Applicable VIN Range
PE1C-13-96ZA	Charcoal Canister	1	JM3KE*****299999 and lower
PY1J-13-96ZA	Charcoal Canister	1	JM3KE*****300001 and higher

## WARRANTY INFORMATION

### NOTE:

- This warranty information applies only to verified customer complaints on vehicles eligible for warranty repair.
- This repair will be covered under Mazda's New Vehicle Limited Warranty or Calif. Emission Warranty Short Term.
- Additional diagnostic time cannot be claimed for this repair.

Warranty Type	A
Symptom Code	6X
Damage Code	9W
Part Number Main Cause	PE1C-13-96ZA or PY1J-13-96ZA
Quantity	1
Operation Number / Labor Hours:	XXK5BXRX / 0.4 Hrs.