

© 2014 Mazda Motor of America, Inc.

Subject: RATTLE NOISE FROM FRONT DOOR GLASS	Bulletin No: 09-017/14
	Last Issued: 03/05/2014

BULLETIN NOTE

- This bulletin supersedes the previous bulletin 09-011/13 issued 04/17/13. The APPLICABLE MODEL(S)/VINS, REPAIR PROCEDURE, PART(S) and WARRANTY INFORMATION have been revised.
- Changes are noted below in Red beside the change bar.

APPLICABLE MODEL(S)/VINS

2013-2014 CX-5 vehicles with VINs lower than JM3KE*****433172 (produced before January 13, 2014)

DESCRIPTION

Some vehicles may experience a rattle noise from the front door glass when driving with the window open approx. 1/2 to 4 inches (1 - 10 cm).

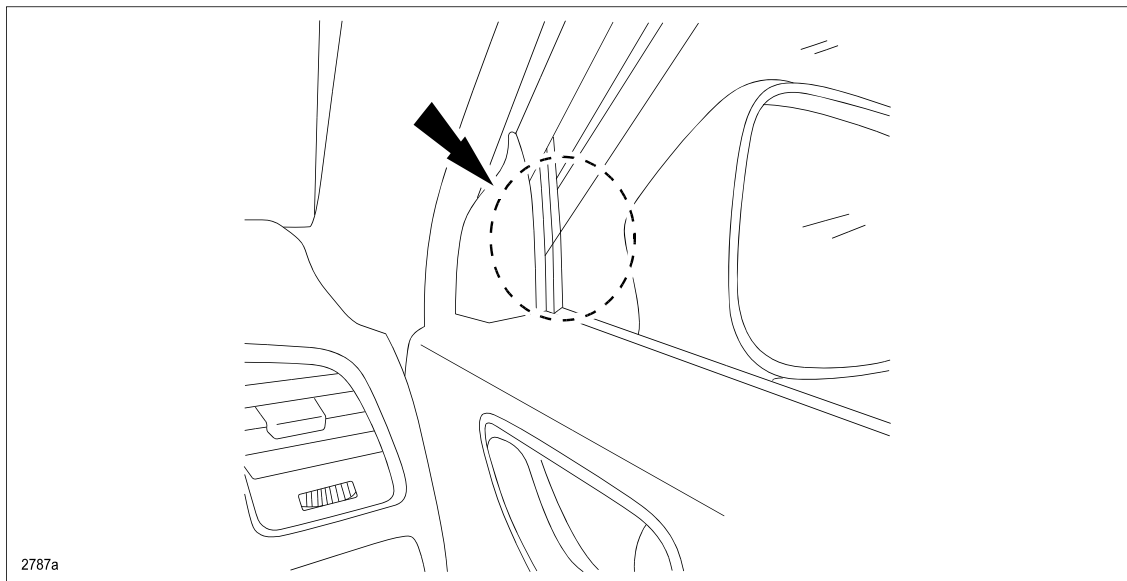

The rattle noise may be caused by insufficient glass run channel holding force. To eliminate this concern, the shape of glass run channel has been changed in order to increase the holding force.

Customers having this concern should have their vehicle repaired using the following repair procedure.

REPAIR PROCEDURE

Verify vehicle VIN, then perform the appropriate repair procedure according to the table below:

VIN Range	Perform:
JM3KE*****100001 to 300112	REPAIR PROCEDURE A
JM3KE*****300113 to 433172	REPAIR PROCEDURE B

REPAIR PROCEDURE A: (VIN Range JM3KE*****100001 to 300112)

1. Verify the customer concern.

NOTE: The rattle noise should go away when holding the slightly opened window by hand or when the window is completely closed.

- If the noise goes away, proceed to the next step.
- If the noise does not go away, this service bulletin does not apply. Troubleshoot the noise according to section 09 (Body and Accessories) of the MS3 online instructions or the Workshop Manual.

2. Open the door glass fully (right side glass run channel shown below).

3. Pull the glass run channel off of the door frame.

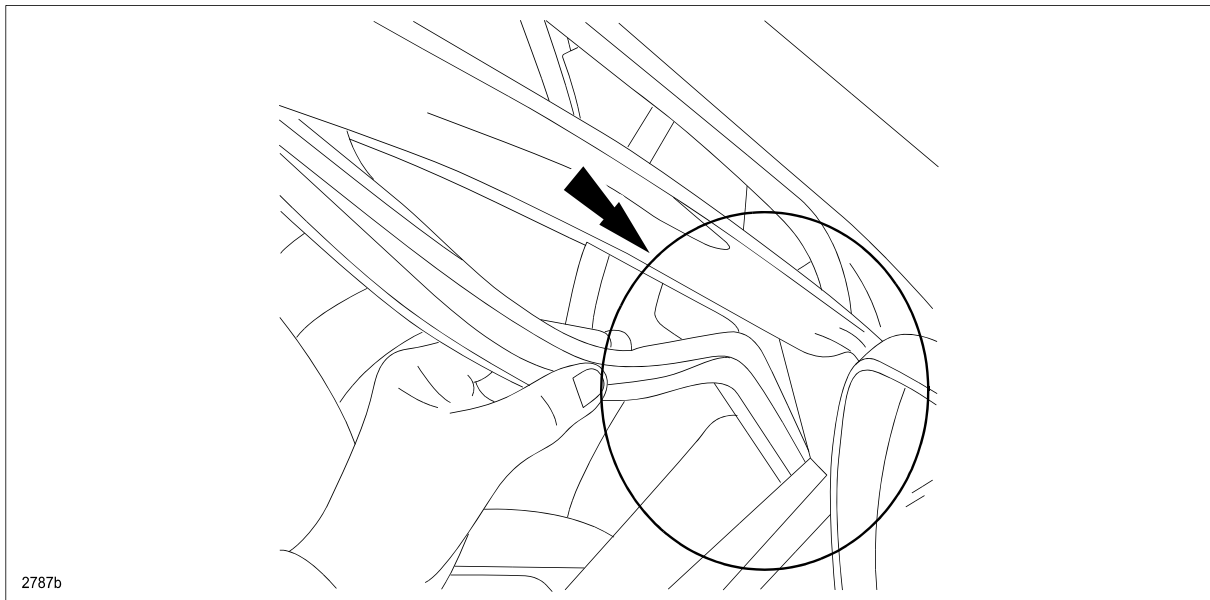

4. Obtain the 0.25 mm thick pad from the Noise Parts Set.
5. Using a straight-edge and sharp knife, cut the pad into the following twelve (12) pieces (as shown below):
 - Four (4) pieces of 7 mm x 100 mm
 - Four (4) pieces of 7 mm x 60 mm
 - Four (4) pieces of 7 mm x 40 mm
6. Stack the four (4) pieces of 7 mm x 100 mm pads on top of one another to create a 1 mm thick pad. Do the same with the 7 mm x 60 mm pads and the 7 mm x 40 mm pads.

NOTE: The final three (3) pad dimensions are shown below:

1. 1 mm x 7 mm x 40 mm
2. 1 mm x 7 mm x 60 mm
3. 1 mm x 7 mm x 100 mm

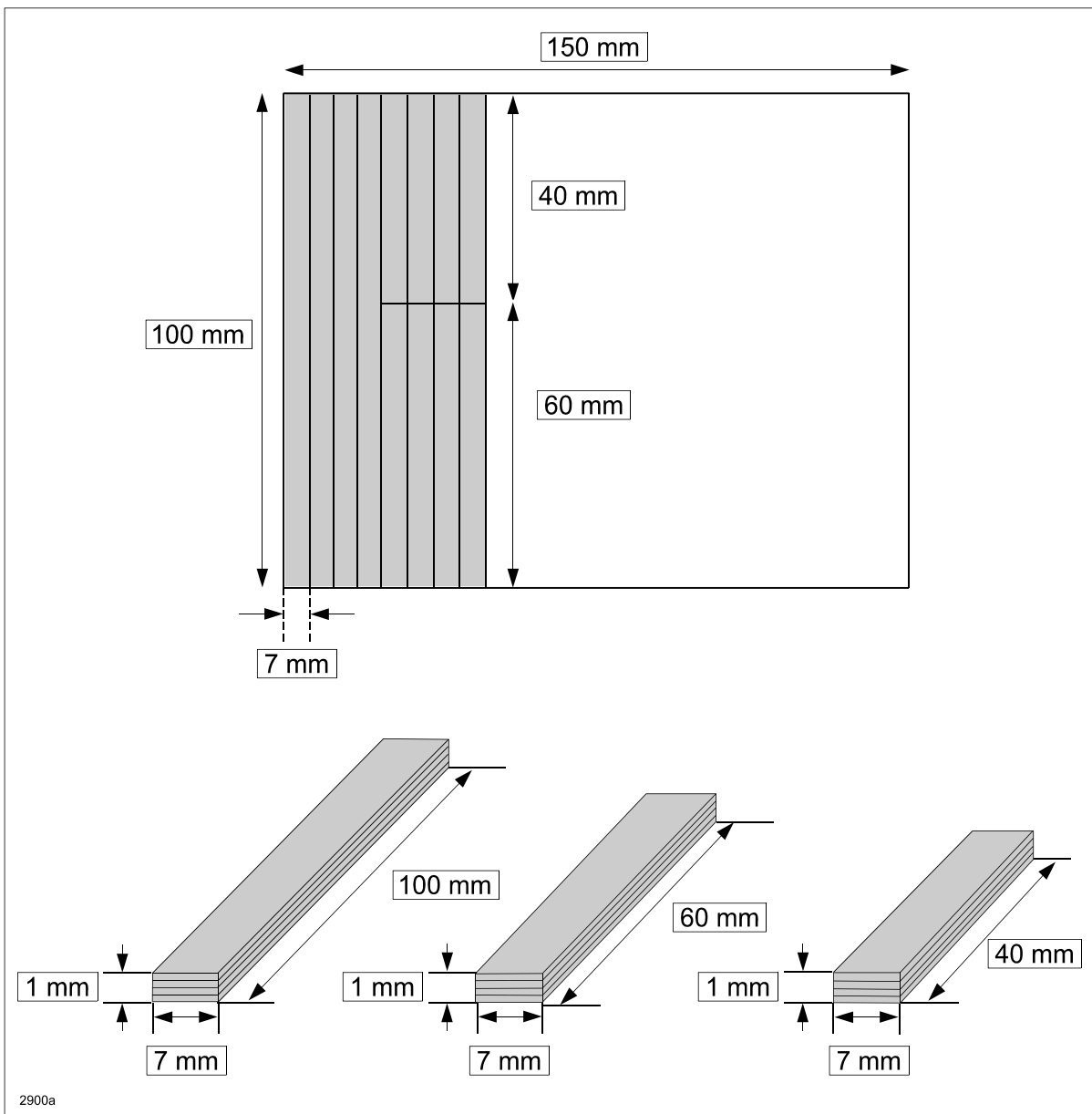

7. Degrease the glass run channel where the **three (3)** pads will be applied to the **outer side of the glass run channel (A)** and the **inner side of the glass run channel (B)**.

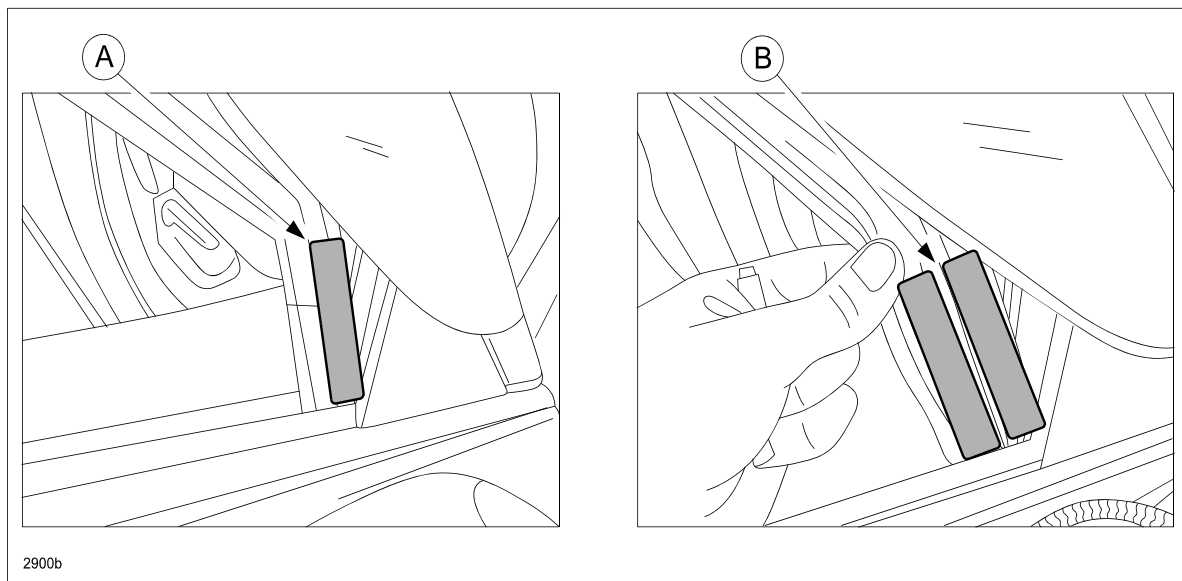

8. Apply an adhesion promoter (one that is suitable for use on plastic) to the **three (3)** locations where the pads will be attached.

NOTE:

- Obtain adhesion promoter locally.
- Recommended adhesion promoter: 3M K-540NT, K500 or 4298UV. If these products cannot be obtained, any adhesion promoter suitable for plastic can be used.

9. Following steps a-c, attach the **three (3)** pads to the glass run channel **as shown** below.
- Attach the 100 mm pad (B) with 40 mm of it above the molded joint line (A) and 60 mm below it.
 - Attach the 60 mm pad (C) directly below the molded joint line (A).
 - Attach the 40 mm pad (D) directly above the molded joint line (A).

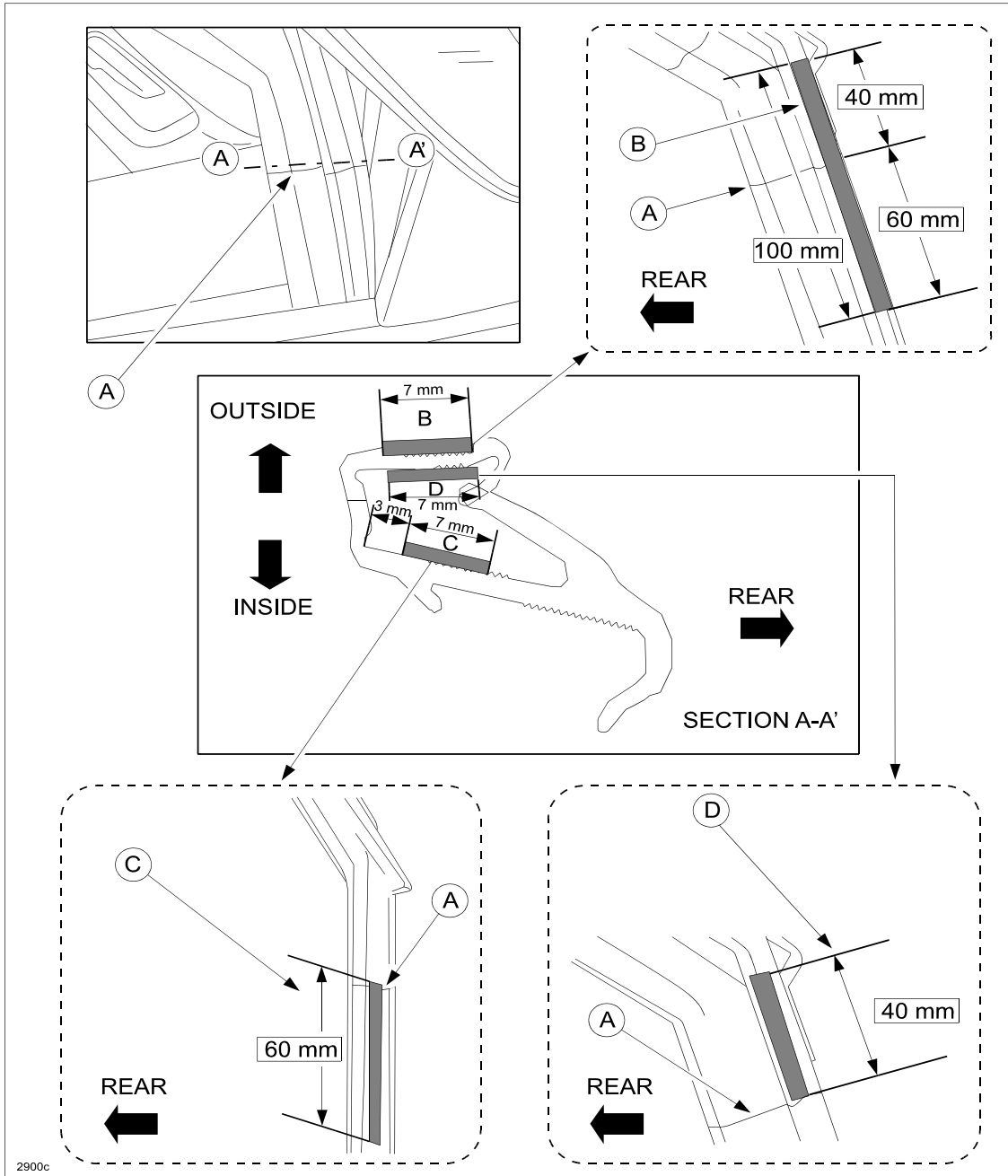

- Reinstall the glass run channel back to the original position.
- Operate the door glass up and down to verify proper operation.
- Repeat the repair on the opposite side glass run channel as necessary.

REPAIR PROCEDURE B: (VIN Range JM3KE***300113 to 433172)**

1. Verify the customer concern.

NOTE: The rattle noise should go away when holding the slightly opened window by hand or when the window is completely closed.

- If the noise goes away, proceed to the next step.
- If the noise does not go away, this service bulletin does not apply. Troubleshoot the noise according to section 09 (Body and Accessories) of the MS3 online instructions or the Workshop Manual.

2. Open the door glass fully (right side glass run channel shown below).

3. Pull the glass run channel off of the door frame.

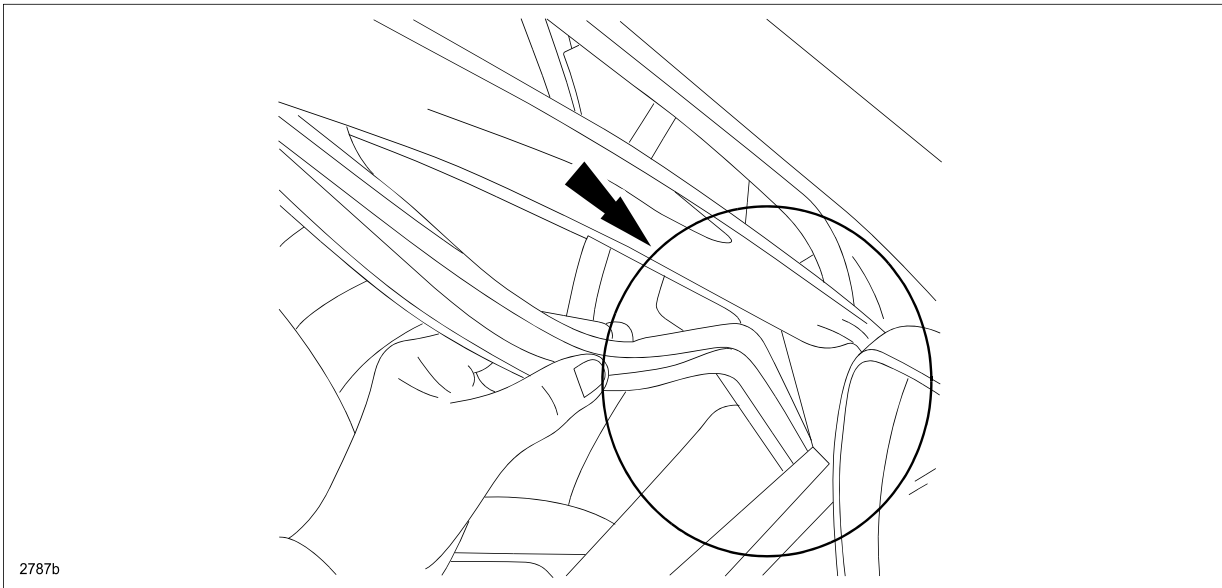

4. Obtain the 0.25 mm thick pad (A) from the Noise Parts Set.
5. Using a straight-edge and sharp knife, cut the pad into eight (8) equal pieces of 7 mm x 40 mm:
6. Stack four (4) pads on top of one another to create a 1 mm thick pad.
7. Repeat Step 6 to create a second pad with the remaining four (4) pieces.

NOTE: Final pad dimensions: 1 mm x 7 mm x 40 mm

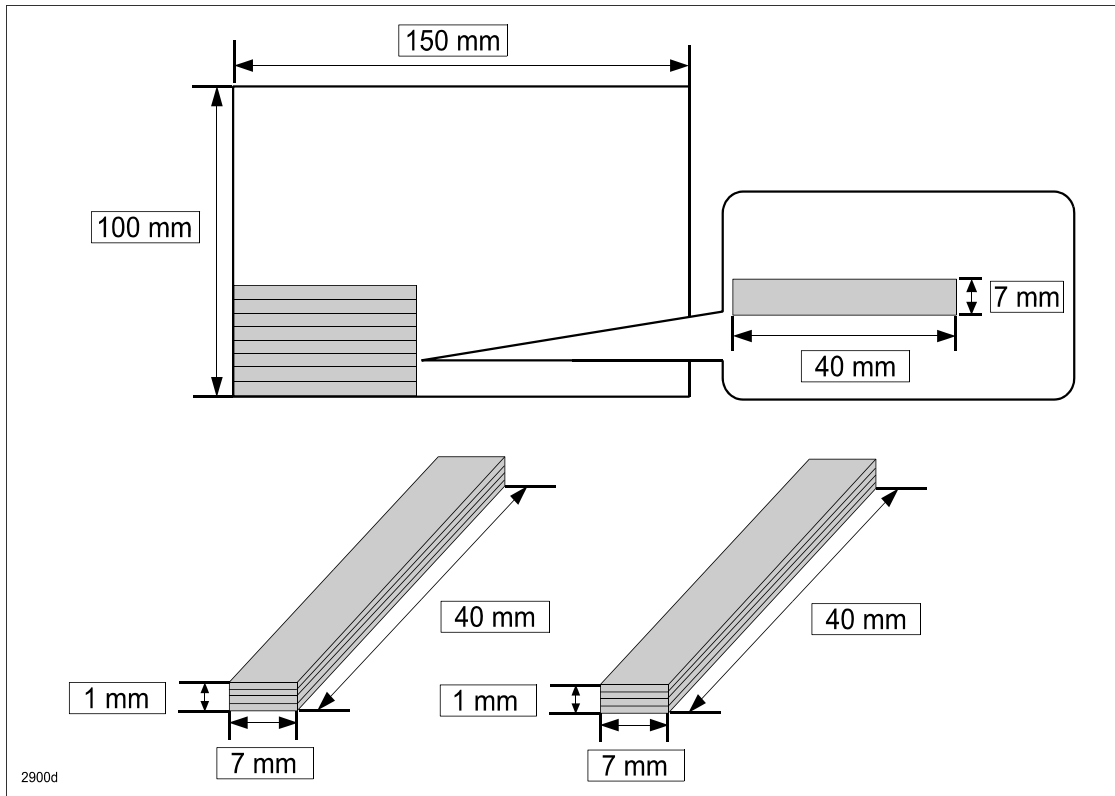

8. Degrease the glass run channel where the pads will be applied to the **outer side of the glass run channel (A)** and the **inner side of the glass run channel (B)**.

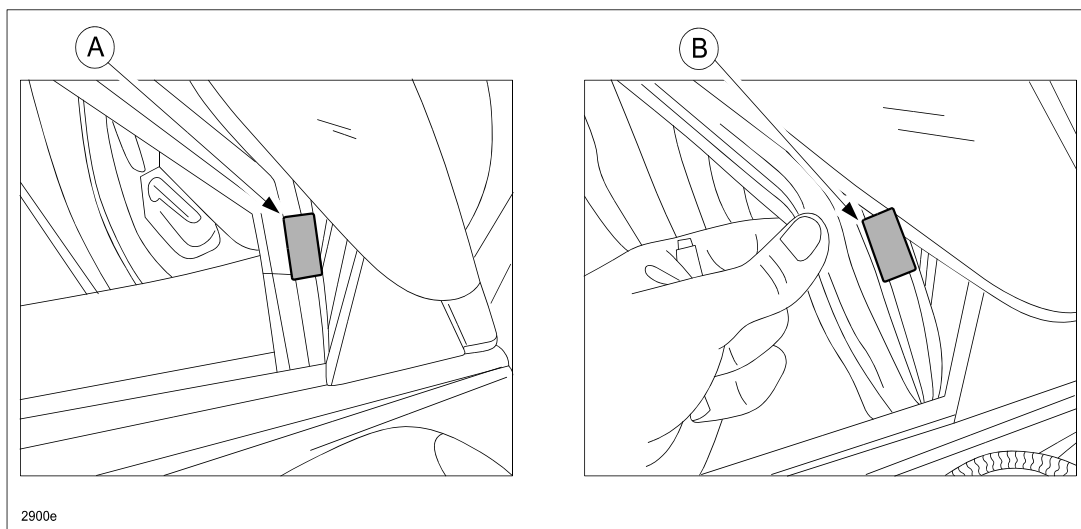

9. Apply an adhesion promoter (one that is suitable for use on plastic) to the two (2) locations where the pads will be attached.

NOTE:

- Obtain adhesion promoter locally.
- Recommended adhesion promoter: 3M K-540NT, K500 or 4298UV. If these products cannot be obtained, any adhesion promoter suitable for plastic can be used.

10. Following steps a-b, attach the pads to the glass run channel as shown below.

a. Attach the 40 mm pad (B) directly above the molded joint line (A).

b. Attach the 60 mm pad (C) directly below the molded joint line (A).

NOTE: There is already a pad attached to position D.

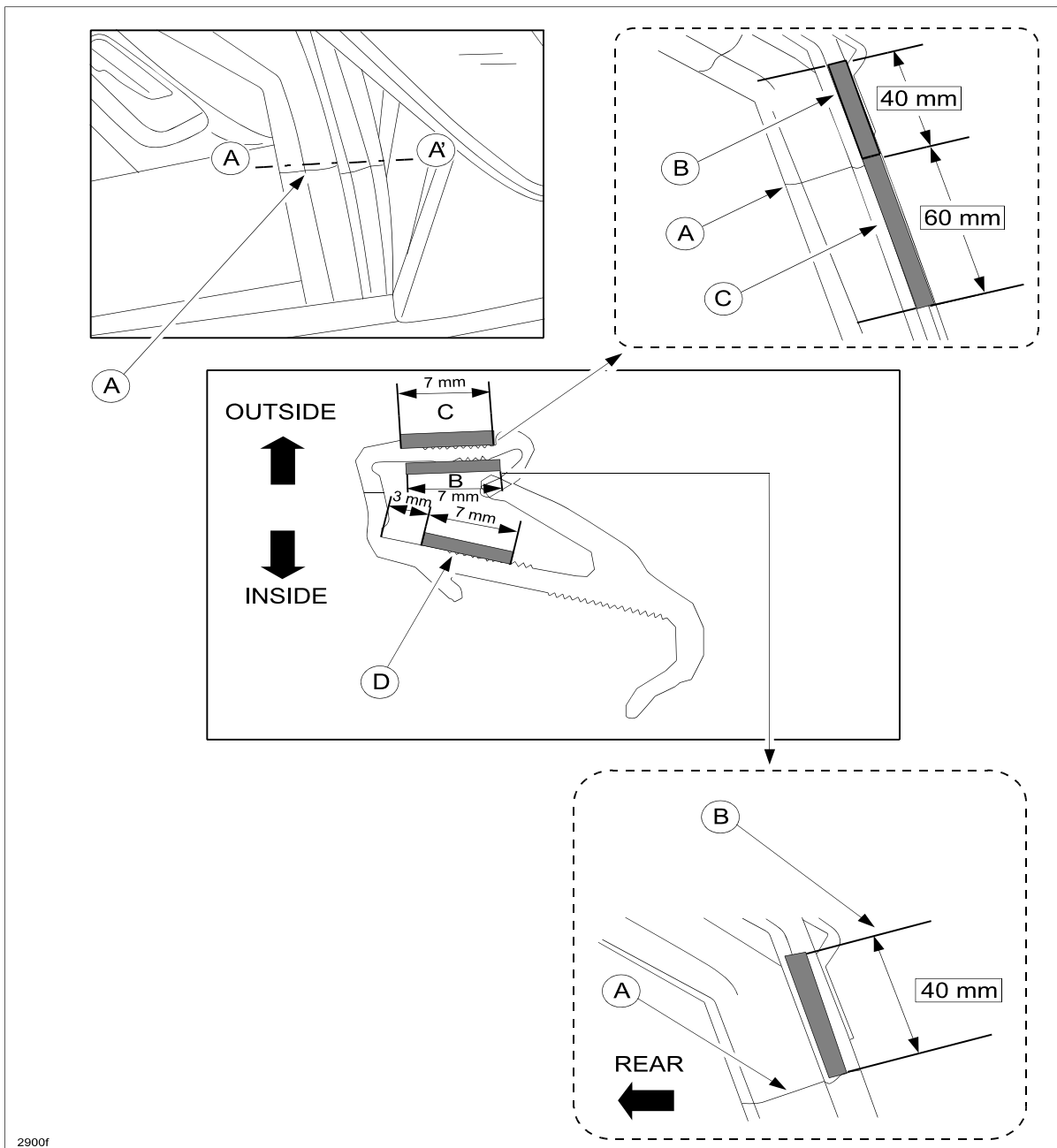

2900f

11. Reinstall the glass run channel back to the original position.
12. Operate the door glass up and down to verify proper operation.
13. Repeat the repair on the opposite side glass run channel as necessary.

PART(S) INFORMATION

Part Number	Description	Qty.	Notes
TA01-76-100	Noise Parts Set	1	Use 0.25 mm thick non-woven fabric. Repair Procedure A: One sheet can make two (2) repairs. Repair Procedure B: One sheet can make five (5) repairs.

WARRANTY INFORMATION

NOTE:

- This warranty information applies only to verified customer complaints on vehicles eligible for warranty repair.
- This repair will be covered under Mazda's New Vehicle Limited Warranty term.
- Additional diagnostic time cannot be claimed for this repair.

Warranty Type	A
Symptom Code	82
Damage Code	97
Part Number Main Cause	KD53-59-605
Quantity	0
Operation Number / Labor Hours	XXJ5CXRX / 0.3 Hrs. (one side) XXJ5DXRX / 0.4 Hrs. (both sides)

NOTE: Do not claim the noise parts set (P/N TA01-76-100) as a related part. The amount of fabric and adhesion promotor used for this repair is included in the labor allowance.