

© 2014 Mazda Motor of America, Inc.

Subject: RATTLE NOISE FROM INSTRUMENT PANEL AND/OR CREAK NOISE FROM A-PILLAR OVER ROUGH / BUMPY ROADS	Bulletin No: 09-002/14
	Last Issued: 01/08/2014

BULLETIN NOTE

- This bulletin supersedes the previous bulletin 09-009/12 issued 03/09/12, 07/03/12 and 08/02/12. The APPLICABLE MODEL(S)/VINS, DESCRIPTION, REPAIR PROCEDURE and WARRANTY INFORMATION have been revised.
- Changes are noted below in Red beside the change bar.

APPLICABLE MODEL(S)/VINS

2013-2014 CX-5

DESCRIPTION

While driving over rough or bumpy roads, some vehicles may exhibit a rattle noise from the instrument panel and/or a creak noise from the A-pillar.

Rattle Noise From Instrument Panel:

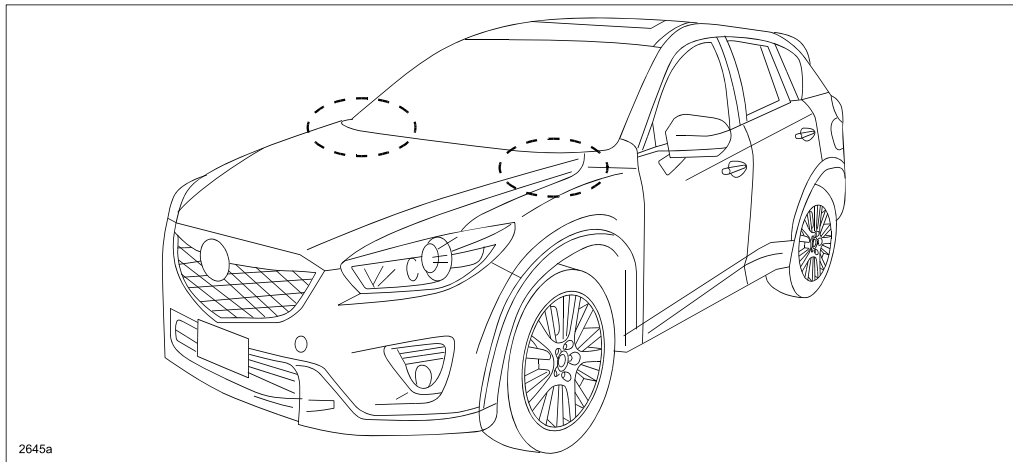

CONSUMER NOTICE: The information and instructions in this bulletin are intended for use by skilled technicians. Mazda technicians utilize the proper tools/equipment and take training to correctly and safely maintain Mazda vehicles. These instructions should not be performed by "do-it-yourselfers." Customers should not assume this bulletin applies to their vehicle or that their vehicle will develop the described concern. To determine if the information applies, customers should contact their nearest authorized Mazda dealership. Mazda North American Operations reserves the right to alter the specifications and contents of this bulletin without obligation or advance notice. All rights reserved. No part of this bulletin may be reproduced in any form or by any means, electronic or mechanical---including photocopying and recording and the use of any kind of information storage and retrieval system ---without permission in writing.

The rattle noise may be caused by low cowl panel (A) mounting bolt (B) torque.

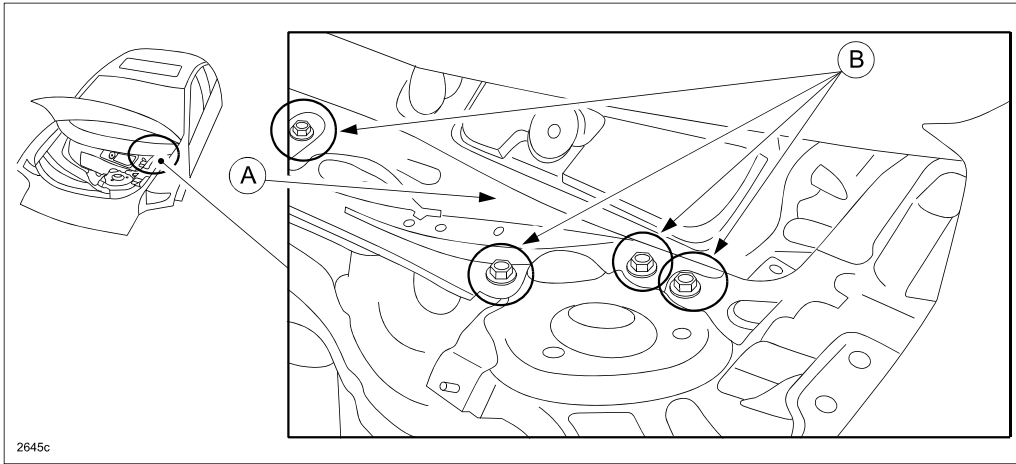

Creak Noise From A-Pillar:

This noise may be caused by two joined panels (A) scraping together at the A-pillar. The panel weld areas have been improved during the mass-production of vehicles with VINs JM3KE*****128359 (produced June 1, 2012) or higher.

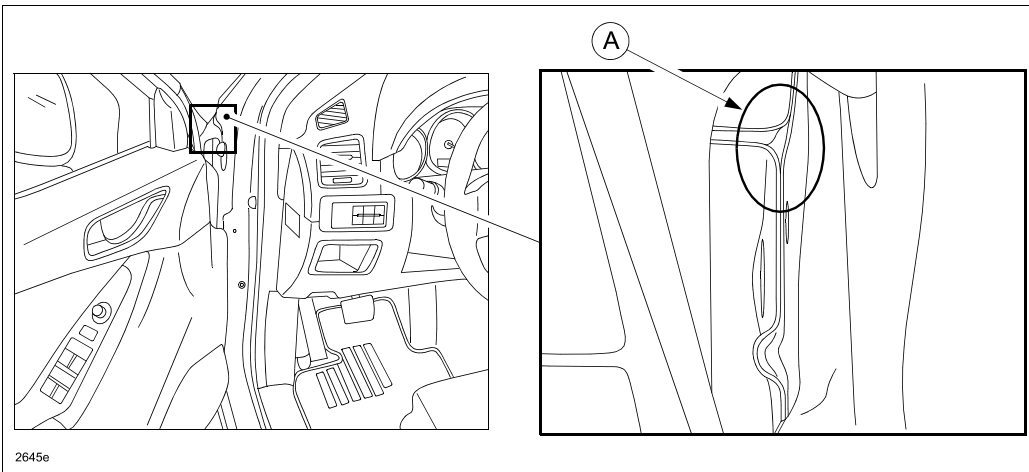

Customers having these concerns should have their vehicle repaired using the following repair procedures.

REPAIR PROCEDURE

While verifying the customer concern, it may be difficult to distinguish the rattle noise from the creak noise. Use the table below to determine the appropriate repair.

Subject Vehicle	Required Repair(s)
For vehicles produced on or before June 1, 2012 with VINs of JM3KE*****128359 or lower.	Perform “Rattle Noise From Instrument Panel” AND “Creak Noise From A-Pillar” repairs.
For vehicles produced on or after June 2, 2012 with VINs of JM3KE*****128360 or higher.	Perform “Rattle Noise From Instrument Panel” repair only.

Rattle Noise From Instrument Panel:

1. Remove the cowl grille according to the online MS3 instructions or the Workshop Manual (section 09-16 COWL GRILLE REMOVAL/INSTALLATION).

CAUTION: To avoid damaging the windshield, be sure to apply adequate protection along the bottom edge of the glass (i.e. tape or a sliced rubber hose) before retightening the cowl panel bolts.

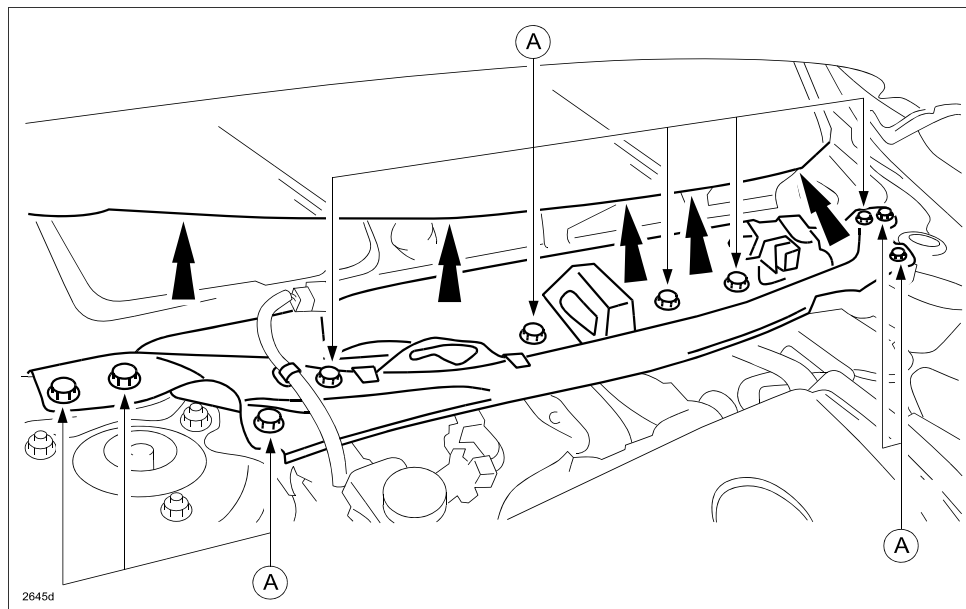

2. Retighten all ten (10) cowl panel bolts (A) to:
Tightening Torque: 17-22 ft. lbs {22-30 Nm, 2.3-3.0 kgf-m}
3. Reinstall the cowl grille according to the online MS3 instructions or the Workshop Manual (section 09-16 COWL GRILLE REMOVAL/INSTALLATION).

Creak Noise From A-Pillar:

Enlarge the clearance between two (2) panels (A) using an appropriate tool (i.e. flat-blade screwdriver).

NOTE: In the illustration (below, right), the front fender is removed for viewing purpose only. It is not necessary to remove the front fender for this repair.

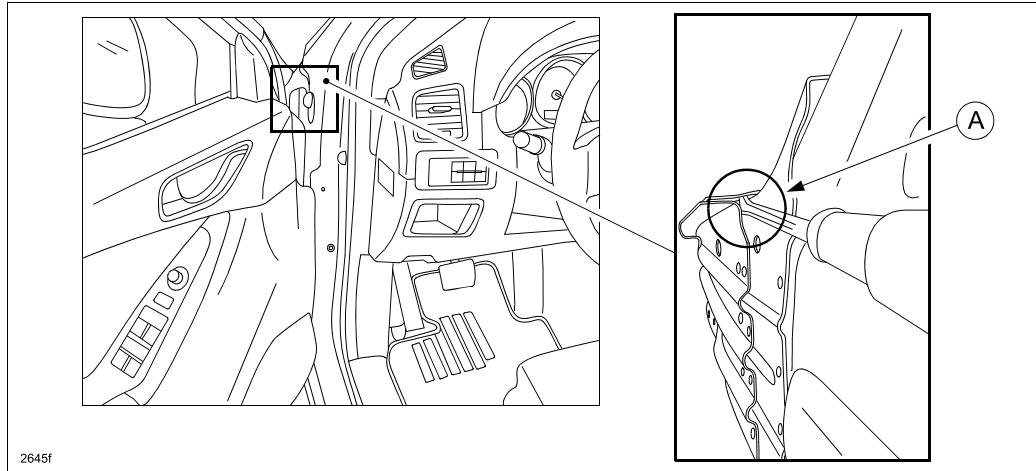

1. Identify which side the noise is coming from (repair only the problem side).
2. Remove the mud guard according to the MS3 online instructions or the Workshop Manual (section 09-16 MUD GUARD REMOVAL/INSTALLATION).
3. Remove the cowl side seal plate (A) and fender seal plate (B).

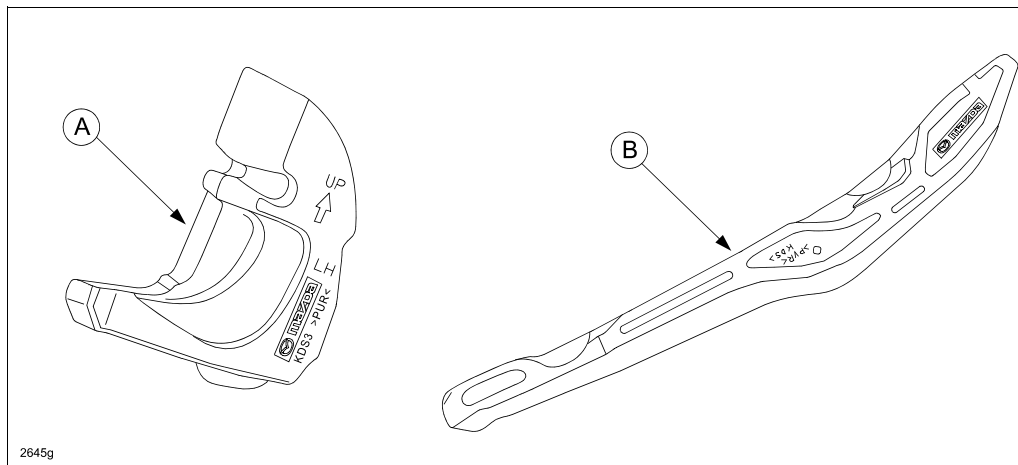

4. Open the front door and place a flat-blade screwdriver with protection tape on the tip (B) between the two panels at joint (A).

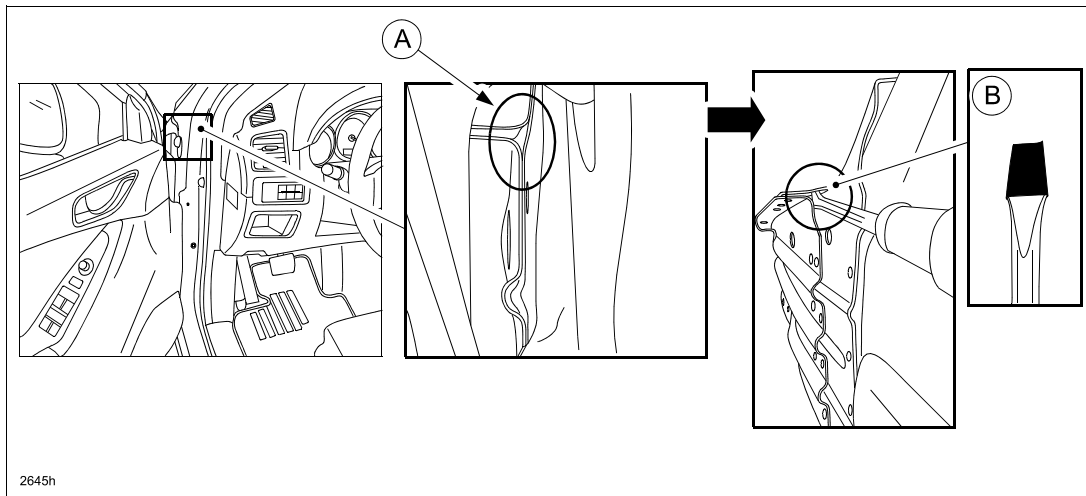

5. Bend the cowl side reinforcement panel (A) to create a clearance of more than 1 mm between the panels.

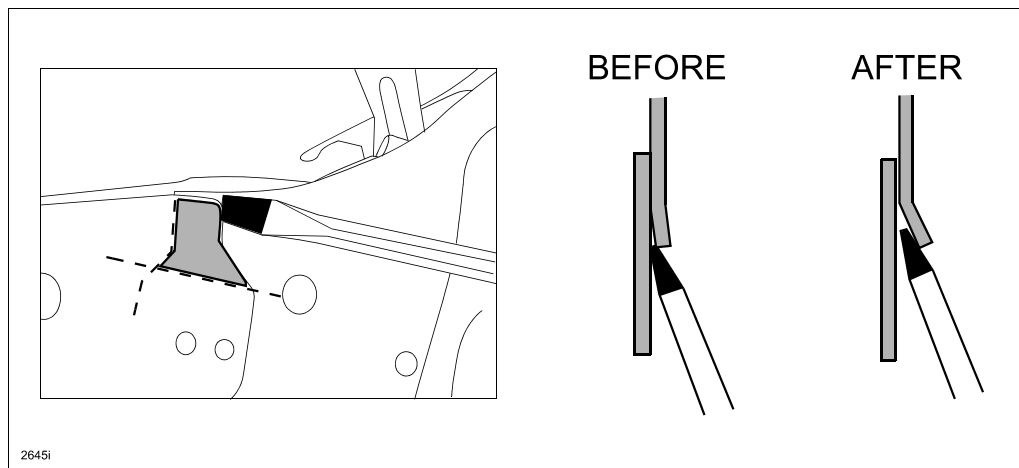

NOTE:

- To avoid damaging the paint, wrap protection tape around the tip of the screwdriver.
- If there are scratches on the panels, apply appropriate corrosion protection primer.

6. Reinstall the removed parts in the reverse order of removal.

NOTE: Passenger Side Only: When reinstalling the cowl side seal plate, make sure to install the rear window washer hose (B) in the opening (A) to avoid hose damage.

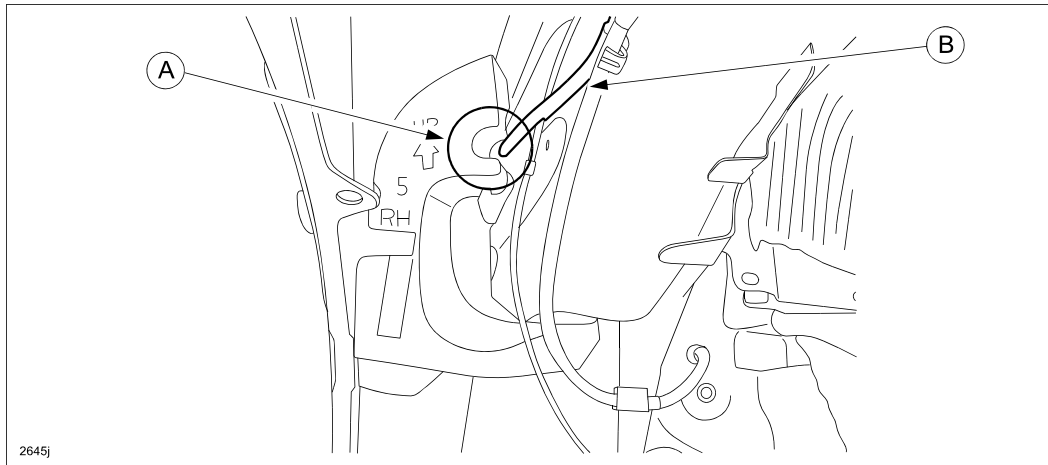

7. If necessary, repeat Steps 1 - 6 on other side.
8. Road test vehicle and verify noise has been eliminated.

WARRANTY INFORMATION

NOTE:

- This warranty information applies only to verified customer complaints on vehicles eligible for warranty repair.
- This repair will be covered under Mazda's New Vehicle Limited Warranty term.
- Additional diagnostic time cannot be claimed for this repair.

RATTLE AND CREAK NOISE REPAIRS:	
Warranty Type	A
Symptom Code	82
Damage Code	9G
Part Number Main Cause	9KD8-00-816B (bolt)
Quantity	0
Operation Number / Labor Hours:	XXK28ARX / 0.7 Hrs. (one side) XXK28BRX / 1.1 Hrs. (both sides)

NOTE: Cracked/damaged windshield glass will not be covered under warranty.

RATTLE NOISE REPAIR ONLY:	
Warranty Type	A
Symptom Code	82
Damage Code	9G
Part Number Main Cause	9KD8-00-816B (Bolt)
Quantity	0
Operation Number / Labor Hours:	XXK29XRX / 0.3 Hrs.