

TECHNICAL BULLETIN
JTBO0306NAS2
01 MAY 2014



© Jaguar Land Rover North America, LLC

NOTE: The information in Technical Bulletins is intended for use by trained, professional Technicians with the knowledge, tools, and equipment required to do the job properly and safely. It informs these Technicians of conditions that may occur on some vehicles, or provides information that could assist in proper vehicle service. The procedures should not be performed by 'do-it-yourselfers'. If you are not a Retailer, do not assume that a condition described affects your vehicle. Contact an authorized Jaguar service facility to determine whether this bulletin applies to a specific vehicle.

This reissue replaces all previous versions. Please destroy all previous versions. Only refer to the electronic version of this Technical Bulletin in TOPIx.

Changes are highlighted in gray

SECTION: 204-02

Suspension 'Knock' / 'Creak' Noise From Rear of Vehicle

AFFECTED VEHICLE RANGE:

F-TYPE (X152)

Model Year: 2014
VIN: K00074-K09174

Engine: V6 S/C 3.0L Petrol
With: Dynamic Suspension

F-TYPE (X152)

Model Year: 2014
VIN: K00074-K09130

Engine: V8 S/C 5.0L Petrol
With: Dynamic Suspension

F-TYPE (X152)

Model Year: 2014
VIN: K00074-K09125

Engine: V6 S/C 3.0L Petrol
Without: Dynamic Suspension

MARKETS:

NAS

CONDITION SUMMARY:

Situation: A suspension 'knock' / 'creak' noise may be heard from the rear of the vehicle when going over bumps or when maneuvering at slow speeds.

Cause: This may be caused by the rear spring / shock absorber.

Action: Should a customer express this concern, follow the Service Instruction outlined below.

PARTS:

T2R11547 Isolator sleeve Quantity: 2

TOOLS:

Refer to Workshop Manual for any required special tools.

WARRANTY:

 **NOTE: Repair procedures are under constant review, and therefore times are subject to change; those quoted here must be taken as guidance only. Always refer to TOPIx to obtain the latest repair time.**

 **NOTE: DDW requires the use of causal part numbers. Labor only claims must show the causal part number with a quantity of zero.**

DESCRIPTION	SRO	TIME (HOURS)	CONDITION CODE	CAUSAL PART
Spring assembly - Rear - Remove/refit -				

Vehicle set	64.20.02	1.4	42	T2R11547
Isolator sleeve - Install	05.10.20	0.20	42	T2R11547



NOTE: Normal Warranty policies and procedures apply.

SERVICE INSTRUCTION:

1. Remove the rear right shock absorber / coil spring assembly (see TOPIX Workshop Manual, section 204-02).

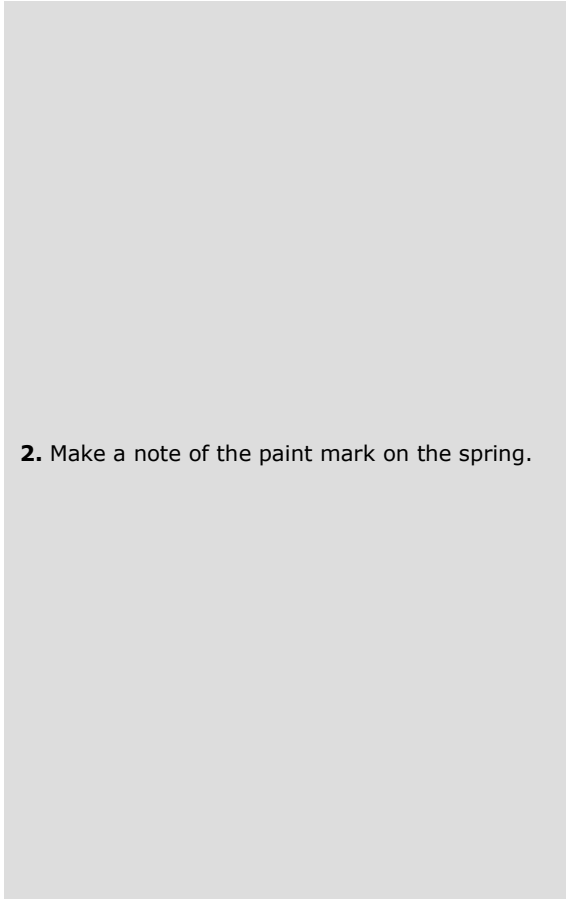

2. Make a note of the paint mark on the spring.



3. Using a suitable marker, make an alignment mark through the spring, packer and shock absorber.

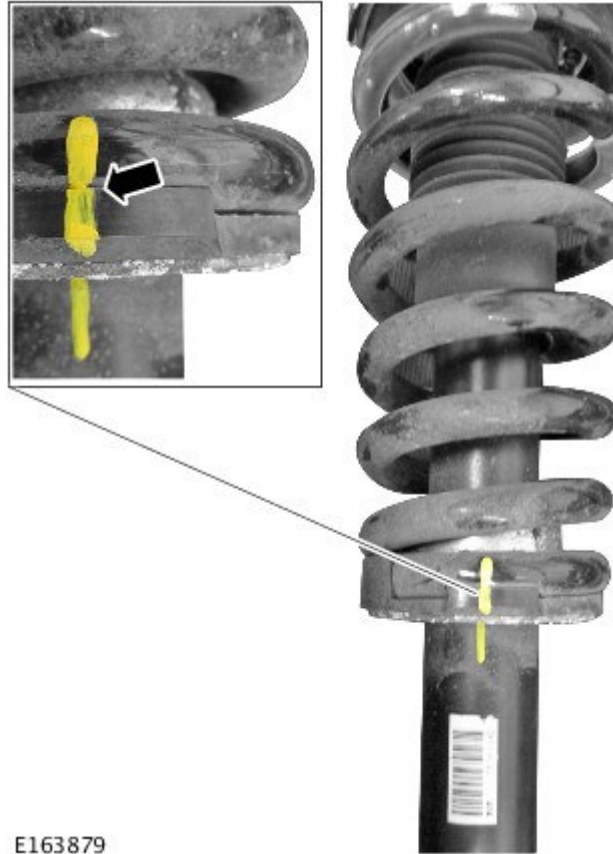

E163879

4.  **CAUTION:** Take extra care when handling the component.

 **CAUTION:** Note the fitted position of the component prior to removal.

 **NOTE:** Make sure that the spring and shock absorber assembly is installed to the spring compressor with the alignment mark facing upwards.

Using a suitable spring compressor, remove the spring assembly top mount.

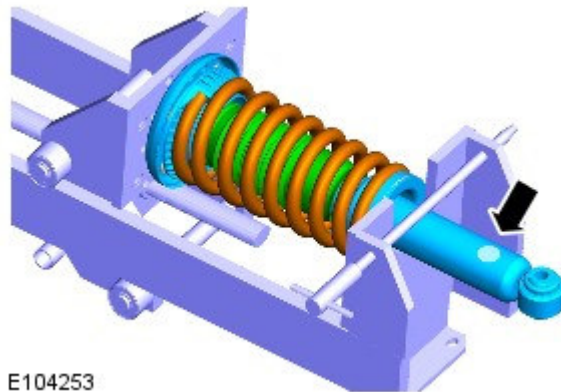

E104253

5.  **NOTE: If previously fitted, remove all spring isolator sleeves.**

Using a suitable cloth, clean the spring in the section where the new sleeve is to be installed.



6.  **NOTE: Note the paint mark.**

Install the new sleeve.

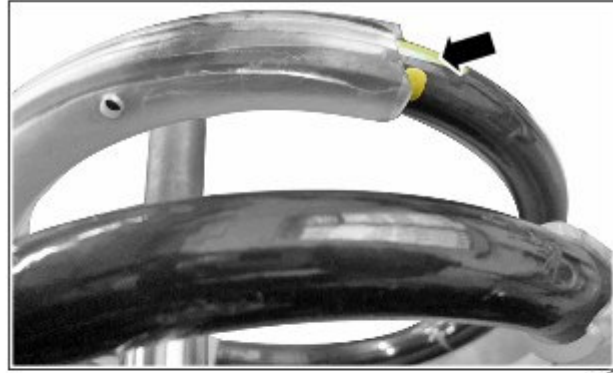

E163880

7.  **NOTE: During assembly, make sure that the alignment marks line up.**

Install the spring assembly top mount.

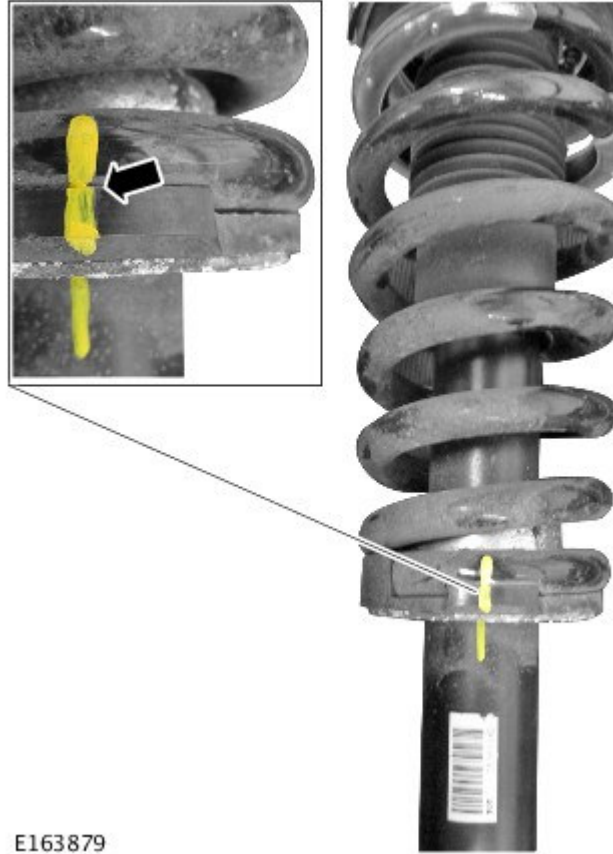

E163879

8.  **NOTE: Make sure the spring assembly is located in the top mount correctly.**

Tighten to:

- Without Dynamic Suspension: 50Nm.
- With Dynamic Suspension: 27Nm.

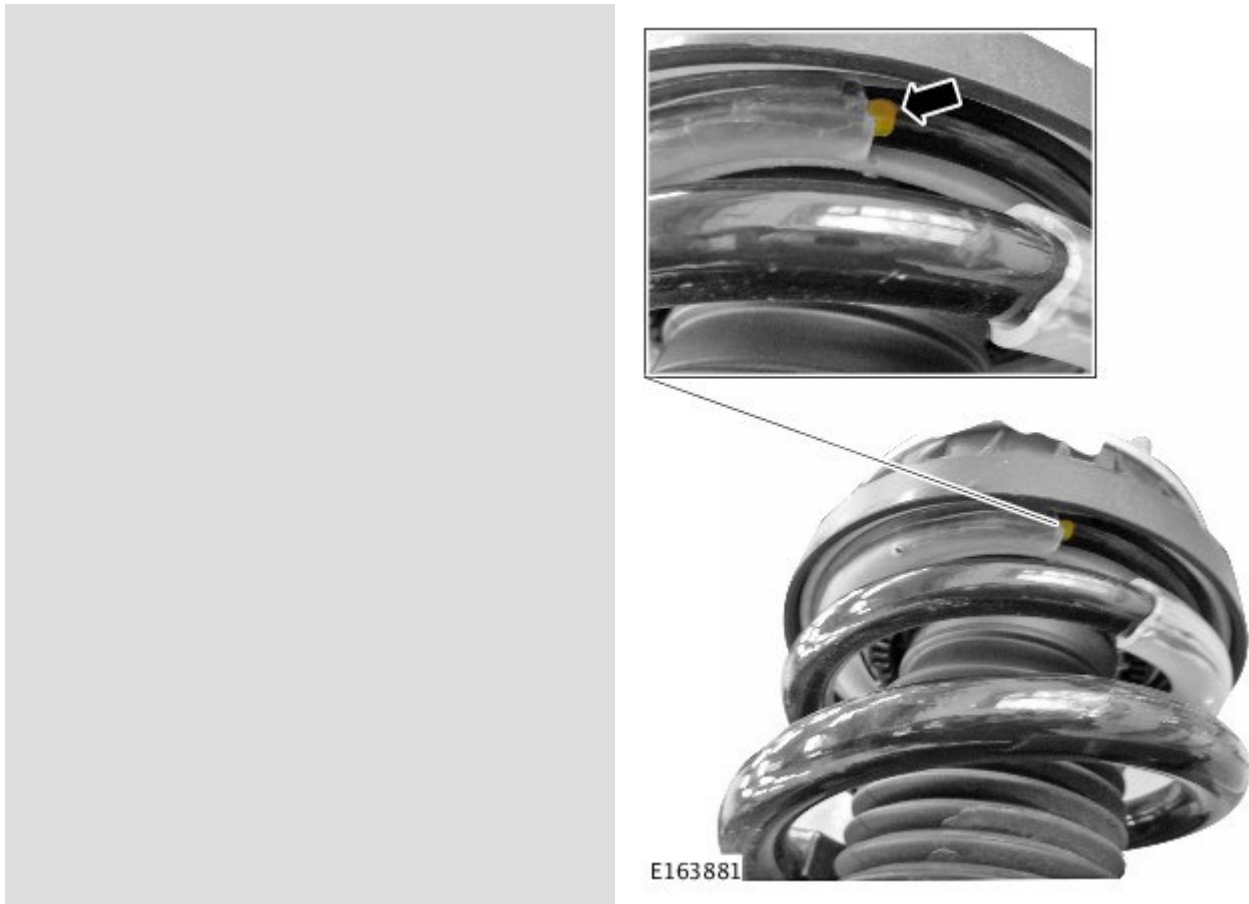

9.  **CAUTION: The final tightening of the suspension components must be carried out with the vehicle weight on its wheels.**

Install the rear right shock absorber (see TOPIx Workshop Manual, section 204-02).

10. Repeat steps 3-9 to the rear left shock absorber.