



INSTRUCTION TO SERVICE

ITS: 5733	
SECTION:	219 Engine and Transmission
WRITTEN BY:	Mike Pearson
SUBJECT:	Replacement Engine Belt Guard and Trans Dipstick Bracket

ITS5733

THIS DOCUMENT AND THE CONTENTS DISCUSSED HEREIN ARE THE CONFIDENTIAL AND PROPRIETARY INFORMATION OF NEW FLYER INDUSTRIES CANADA ULC AND NEW FLYER OF AMERICA INC. AND ARE DISCLOSED BY NEW FLYER IN CONFIDENCE. THIS DOCUMENT AND THE CONTENTS HEREIN ARE NOT TO BE DISCLOSED BY THE INTENDED RECIPIENT WITHOUT THE PRIOR WRITTEN AUTHORIZATION OF NEW FLYER. ANY UNAUTHOIZED DISCLOSURE, REPRODUCTION OR OTHER DISTRIBUTION OF THIS DOCUMENT OR INFORMATION IS STRICTLY PROHIBITED AND MAY RESULT IN ACTION BEING TAKEN AGAINST THE PARTY MAKING THE UNAUTHORIZED DISCLOSURE. THIS DOCUMENT AND ALL COPIES HEREOF MUST BE RETURNED TO NEW FLYER UPON REQUEST.

PROCEDURE:

1. Turn the main battery disconnect switch to the "OFF" position.
2. Open the rear engine access door.
3. Undo the belt guard rubber latch and swing the belt guard assembly open.
4. Remove and replace existing alternator belt guard p/n 340386 with new belt guard p/n 433537 using existing mounting hardware (x5). See Figure 1.

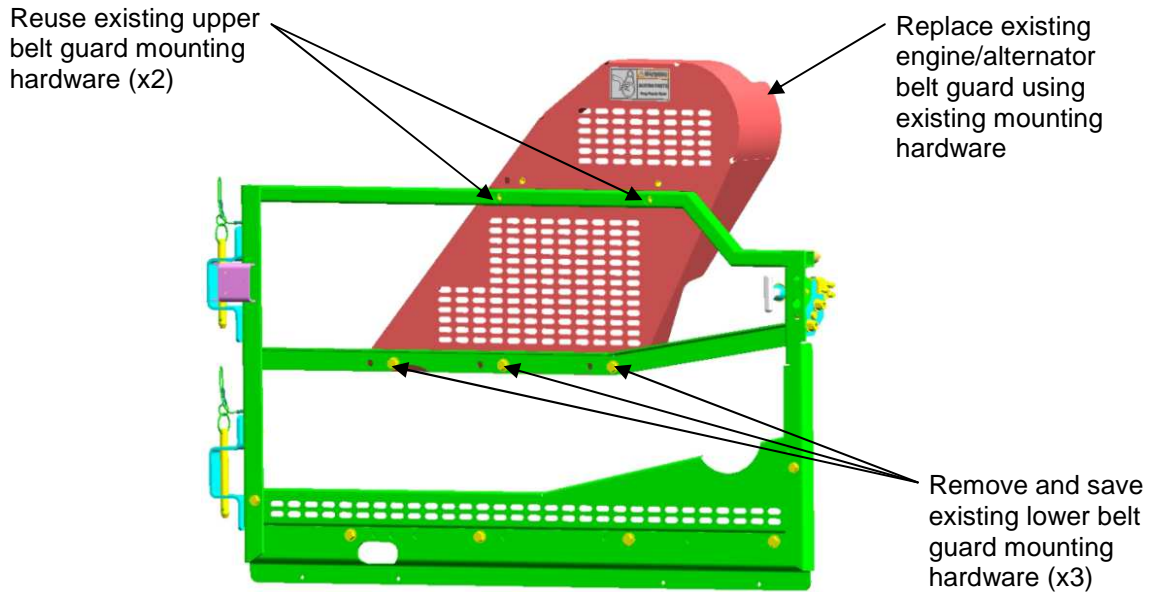

Figure 1: Replace Existing Engine/Alternator Belt Guard

5. Install new warning decal p/n 378069 at dimensions shown in Figure 2.

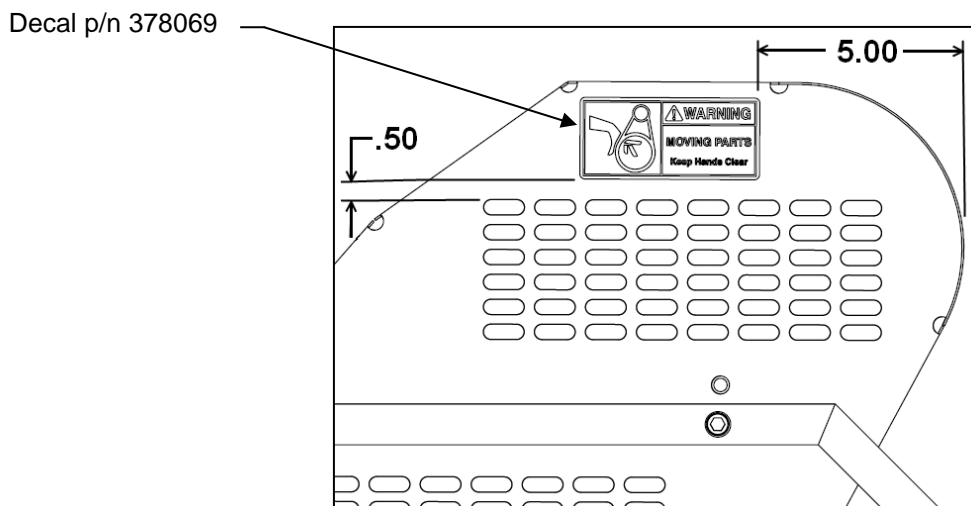

Figure 2: Install New Engine/Alternator Belt Guard Warning Decal



NEW FLYER

6. Remove and save existing transmission dipstick clamp mounting hardware for reuse (x2), see Figure 3.
7. Remove and save existing transmission dipstick mounting bracket bolt and washer for reuse, see Figure 3.

Replace existing transmission dipstick mounting bracket with new bracket p/n 328729 (**Rev B**)

Remove and save existing transmission dipstick mounting bracket bolt and washer for reuse

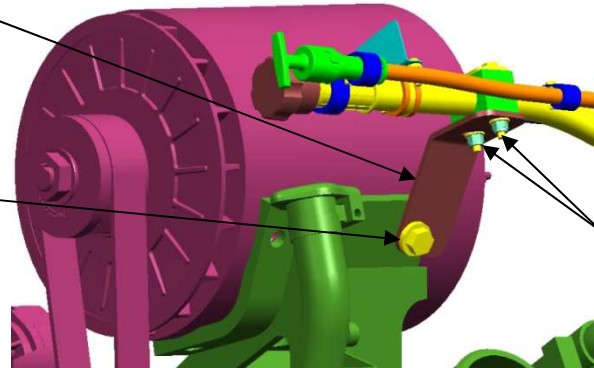

Remove and save existing transmission dipstick clamp mounting hardware (x2),

Figure 3: Remove Old Transmission Dipstick Mounting Bracket

8. Replace existing trans dipstick mounting bracket with new bracket p/n 328729 (**Rev B**), secure to existing alternator bracket using existing bolt and washer removed in Step 7, discard old bracket. Torque existing $\frac{1}{2}$ " bolt to 55-65 ft*lbs, see Figure 4.
9. Secure the existing trans dipstick clamp and dipstick assemblies to the new bracket using the existing hardware removed in Step 6, install so maximum distance between the alternator and the transmission dipstick is achieved, see Figure 4.

Install new transmission dipstick mounting bracket p/n 328729 (**Rev B**)

Install new bracket using existing hardware from step 6, torque existing $\frac{1}{2}$ " Bolt to 55-65 ft*lbs

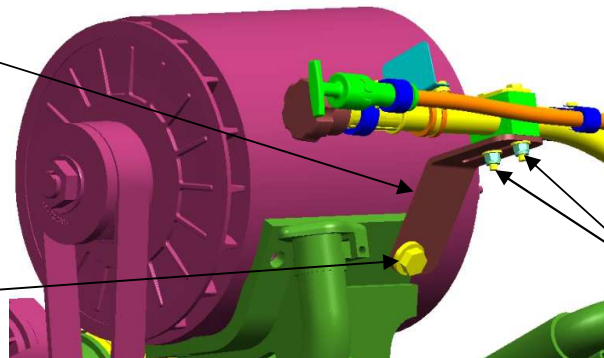

Secure to Bracket using existing hardware removed in Step 6

Figure 4: Installing New Transmission Dipstick Mounting Bracket

10. Close and Latch the Belt Guard Assembly.
11. Close the rear engine access door.
12. Turn the main battery disconnect switch to the "ON" position.
13. Clean up tools and debris, close rear engine door and return bus to service.



NEW FLYER

LABOUR ESTIMATE

	Operation	Men	Hours	Labor Time M X HR
1	Replacement Engine Belt Guard and Trans Dipstick Bracket	1	.50	.50

PARTS REQUIRED

Item	Part Number	Description	Qty. per Coach	Units	Notes
1	328729	Bracket-Trans Dipstick	1	EA	
2	378069	Decal-Warning Belt Guard	1	EA	
3	433537	Assembly-Belt Guard Cummins Gas	1	EA	