

- ATTENTION:**
- GENERAL MANAGER
 - PARTS MANAGER
 - CLAIMS PERSONNEL
 - SERVICE MANAGER

IMPORTANT - All Service Personnel Should Read and Initial in the boxes provided, right.

© 2014 Subaru of America, Inc. All rights reserved.



QUALITY DRIVEN® SERVICE

SERVICE INFORMATION

APPLICABILITY: 2015MY WRX and STI Models **NUMBER:** 09-57-14R
SUBJECT: Fuel (Gasoline) Filler Door (Flap) Does Not Open **DATE:** 06/11/14
REVISED: 08/22/14

INTRODUCTION

This bulletin provides new part number information along with a service procedure to address a customer concern of the fuel filler door not opening when lifting the interior release lever.

COUNTERMEASURE IN PRODUCTION

The new part was incorporated into production **May 30, 2014 starting with VIN F*811136.**

PART INFORMATION

PART NUMBER	DESCRIPTION
51478VA002	Saucer Complete
10024AA300	WRX Fuel Requirement Label
10024AA170	STI Fuel Requirement Label

NOTE: Installation of this new assembly replaces the previous repair procedure which involved installation of a revised spring and a new ring clip. A change was made to the plastic material used in addition to incorporating the new style opener spring.

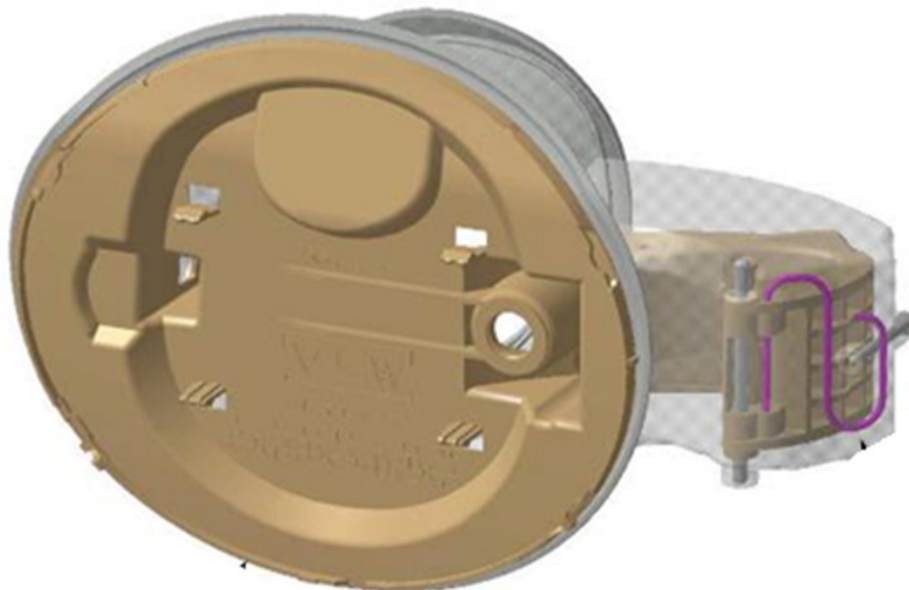

Continued...

CAUTION: VEHICLE SERVICING PERFORMED BY UNTRAINED PERSONS COULD RESULT IN SERIOUS INJURY TO THOSE PERSONS OR TO OTHERS.

Subaru Service Bulletins are intended for use by professional technicians ONLY. They are written to inform those technicians of conditions that may occur in some vehicles, or to provide information that could assist in the proper servicing of the vehicle. Properly trained technicians have the equipment, tools, safety instructions, and know-how to do the job correctly and safely. If a condition is described, DO NOT assume that this Service Bulletin applies to your vehicle, or that your vehicle will have that condition.

SUBARU OF AMERICA, INC. IS ISO 14001 COMPLIANT

ISO 14001 is the international standard for excellence in Environmental Management Systems. Please recycle or dispose of automotive products in a manner that is friendly to our environment and in accordance with all local, state and federal laws and regulations.

SERVICE PROCEDURE / INFORMATION

- Apply protective tape to the edge of the fuel filler door and the vehicle body to protect the finish as shown in the photo below.



- Remove the fuel filler pipe protector (lock ring) by turning it **CLOCKWISE**.

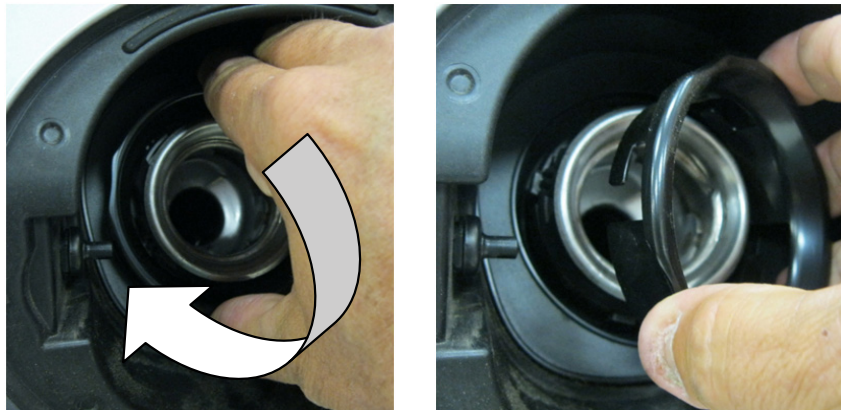

- **CAREFULLY** remove the retaining clips as necessary from the trunk threshold trim and the inner liner as shown in the illustrations below to provide access to the back side of the fuel filler area.

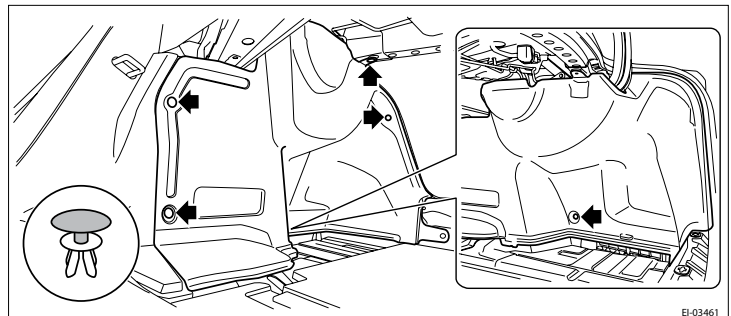
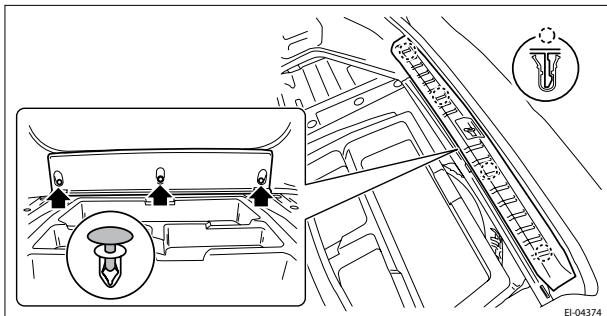

Continued...



- As shown in the illustration below, rotate the housing of the fuel door release latch **COUNTER-CLOCKWISE** and remove it from the assembly.

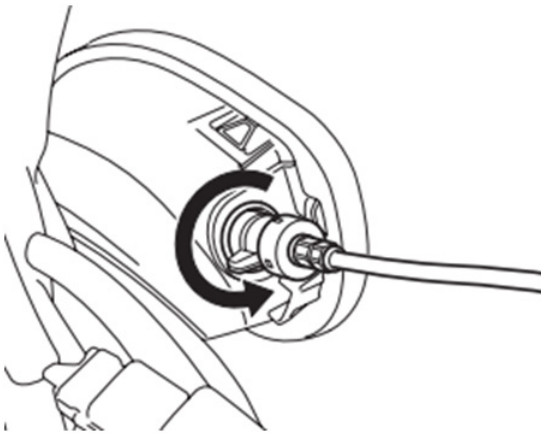

- Using a trim clip removal tool (or equivalent), pry up and remove the ring clip surrounding the fuel filler neck. There are 4 clips securing the ring clip. This part is a one-time use item as it will be broken during removal as shown in the photo below. **REMINDER:** Always take proper precautions to protect the vehicle's finish.

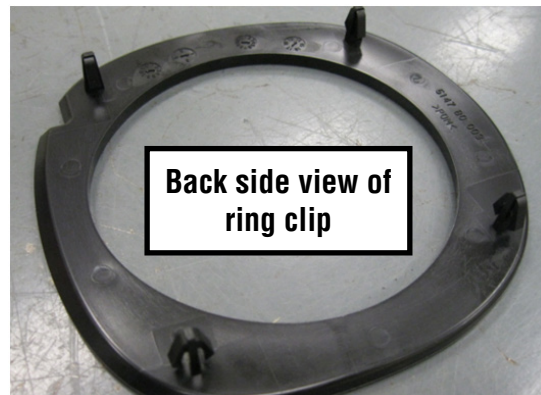
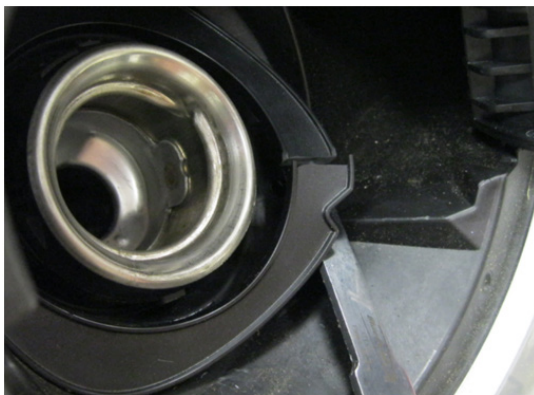

Continued...

- Once the ring clip is removed, the fuel filler door assembly is ready to remove. Using a finger in the latch hole, pull the rear part of the assembly toward you to dislodge it from the body. Once loose from the body, use another finger or a plastic trim tool to “unhook” the rubber insert portion from the front of the filler neck then remove completely as shown below.



- Swap over the fuel cap / tether to the new saucer assembly. Release the tether retaining clip using a plastic trim tool as shown below.



Continued...

- Remove the hex cap nut securing the outer body-color panel to the outside of the filler door.

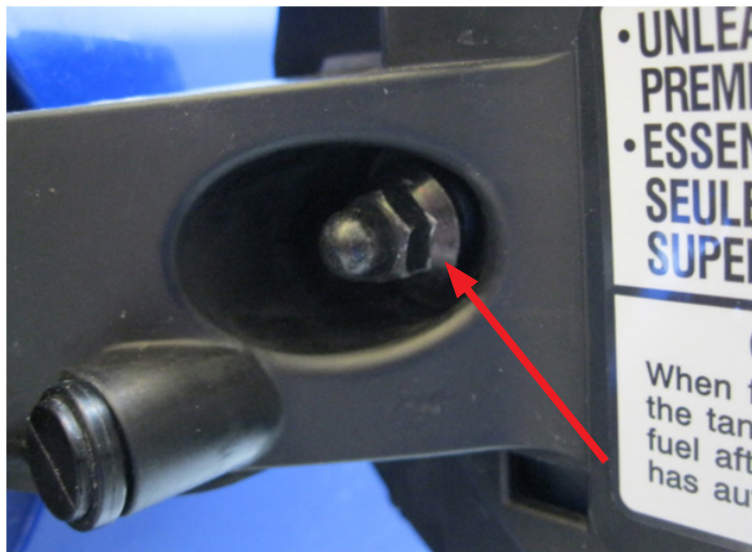

- Using a plastic trim tool, CAREFULLY work the trim tool in between the inner plastic filler door and the metal outer panel to release the 2 upper retaining clips. Once the upper 2 clips are released, the outer panel will be easy to remove from the door. A photo of the inner door with the outer panel removed showing the 4 clip locations is provided below to use as a reference.

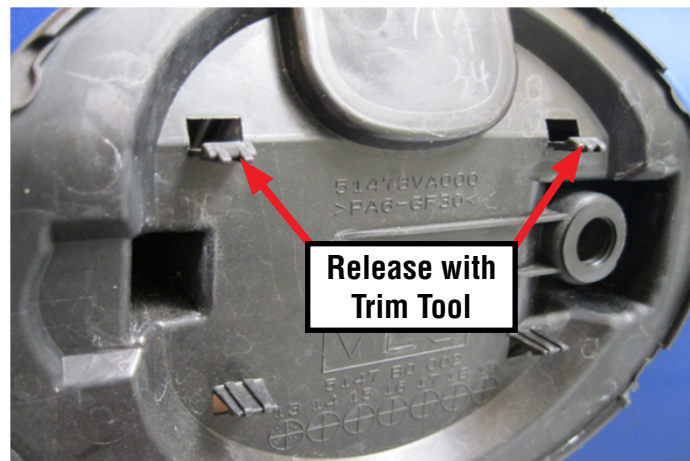

NOTE: Be careful not to drop or damage the outer panel while releasing the retaining clips. Adding a piece of masking tape to secure the outer panel to the plastic door is a good extra safety measure to prevent damage.

Continued...

- Transfer the outer panel to the new saucer's filler door making sure all 4 retaining clips are re-engaged. Reinstall the cap nut onto the outer panel's mounting stud and torque to 5.5 ft. lbs.
- Reinstall the new saucer assembly into the vehicle in the reverse order of removal. The new saucer assembly includes a new plastic ring clip.
- Once the assembly is back in position, secure it in place using the new plastic ring clip. The ring clip can only be installed one way. Make sure the notch is positioned as shown below then make sure all 4 retaining clips lock into position properly.

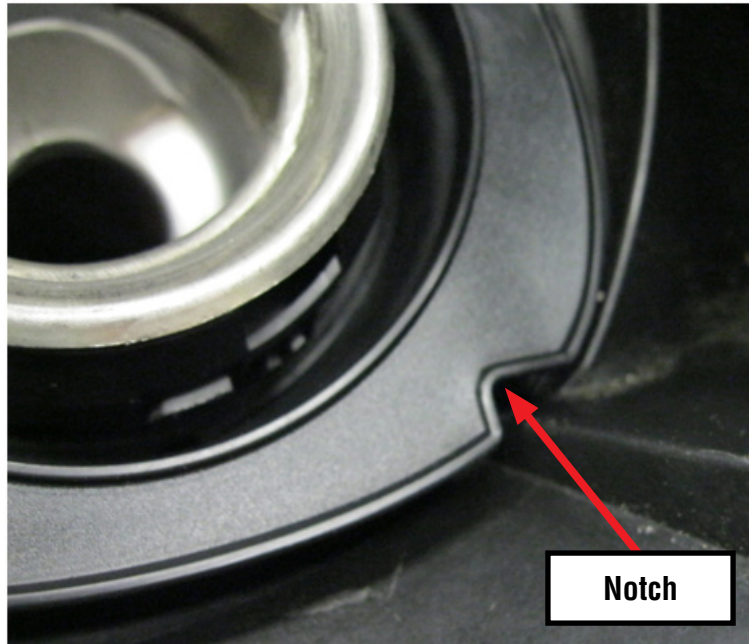

- The remainder of the reassembly is in the opposite order of disassembly.
- Affix the appropriate fuel requirement label to the inside of the filler door.

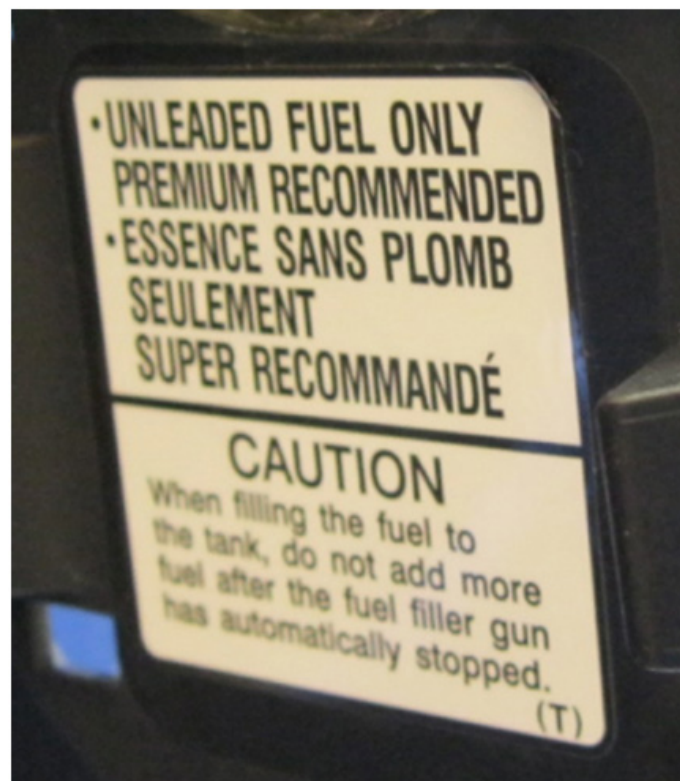

- Confirm proper operation of the fuel filler door release to complete the procedure.

WARRANTY / CLAIM INFORMATION

For vehicles within the Basic New Car Limited Warranty period, this repair may be claimed using the following information:

LABOR DESCRIPTION	LABOR OPERATION #	FAIL CODE	LABOR TIME
WRX / STI FUEL FLAP REPAIR PROCEDURE	A915-556	SGP-48	0.4