

Grade Gripper Quick Release Valve, Replacement CHU, CXU, GU

FSB 593-014, Grade Gripper Quick Release Valve, Replacement

(December 2014)

On some MACK CHU, CXU, and GU trucks built between 04/31/2008 and 01/05/2015, and equipped with the grade gripper function may experience a slow release of the trailer's service brakes. Additionally, a delay in the release of the grade gripper function may be caused by certain truck options and trailer combinations used by the operator. To prevent further issues with the slow release of grade gripper, replace the existing DC-4 double check valve (part number 25110484) with replacement QR-1 quick release valve (part number 20812943). Follow the replacement procedures outlined in this Field Service Bulletin (FSB).

Note: This bulletin does not apply to MACK Trucks Australia.

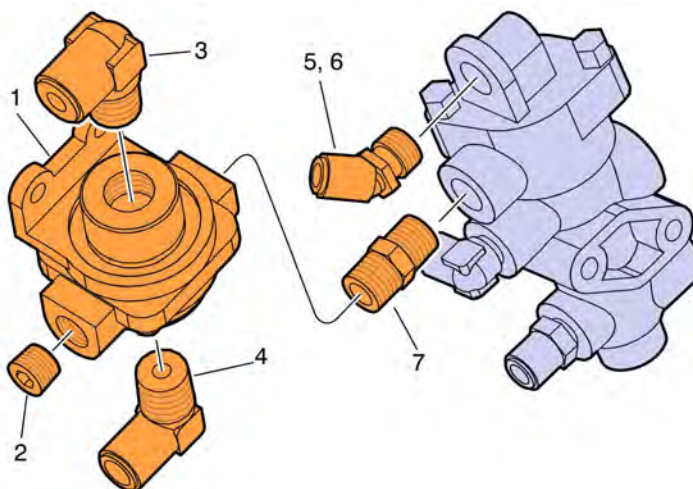

W5095214

Required Parts (Grade Gripper Quick Release Valve)

Item	Description	Part Number	Qty
1	Quick Release Valve	20812943	1
2	Plug, 11,7* 3/8 NPTF	3082875	1
3	Fitting, 9.5*1/2 NPTF	8397706	1
4	Fitting, 12.7*1/2 NPTF	8397707	1
5	Fitting, 12,7*3/8 NPTF (ESP-BAS1 Variant)	8397715	1
6	Fitting, 9.5*3/8 NPTF (UESP Variant)	8397714	1
7	Fitting	25091682	1

Note: Information is subject to change without notice.
Illustrations are used for reference only and can differ slightly from the actual vehicle being serviced. However, key components addressed in this information are represented as accurately as possible.

Procedure

You must read and understand the precautions and guidelines in Service Information, Function Group 5, "General Safety Practices, Brakes and Air Systems" before performing this procedure. If you are not properly trained and certified in this procedure, ask your supervisor for training before you perform it.

- 1 Park the vehicle on a flat and level surface.
- 2 Apply the parking brake.
- 3 Place the transmission in neutral or park.
- 4 Install the wheel chocks.

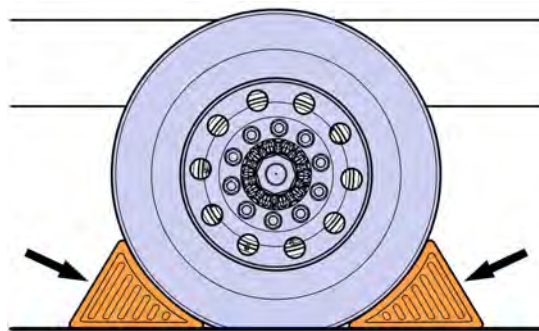

W7086748

- 5 Disconnect the cable from the battery's negative terminal.

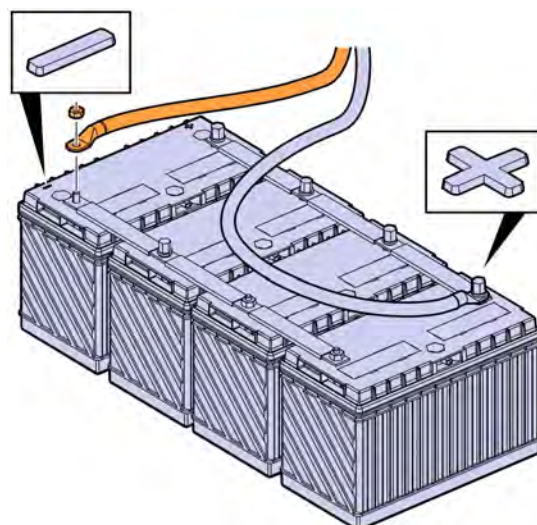

W3086747

- 6 Drain the air system completely.
- 7 Using the proper air line removal tool, remove the air lines from the DC-4 double check valve and tractor protection valve.

Note: Note the position of the air lines for installation purposes.

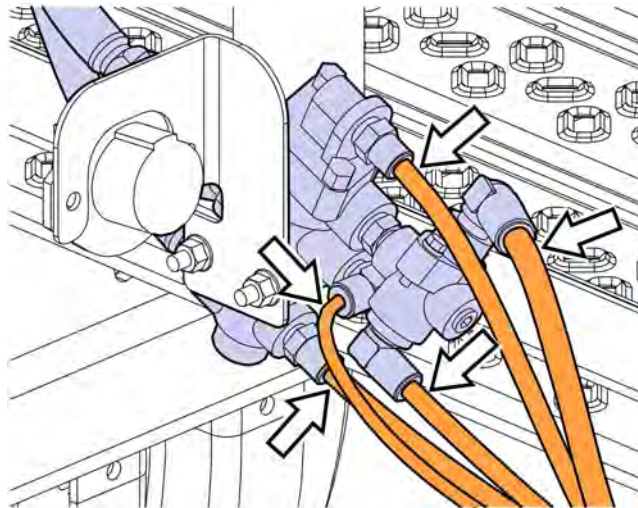

W5095215

- 8 Remove the fasteners and spacers securing the tractor protection valve and the trailer electrical receptacle bracket to the truck cross member.

Note: Store the fasteners for reuse.

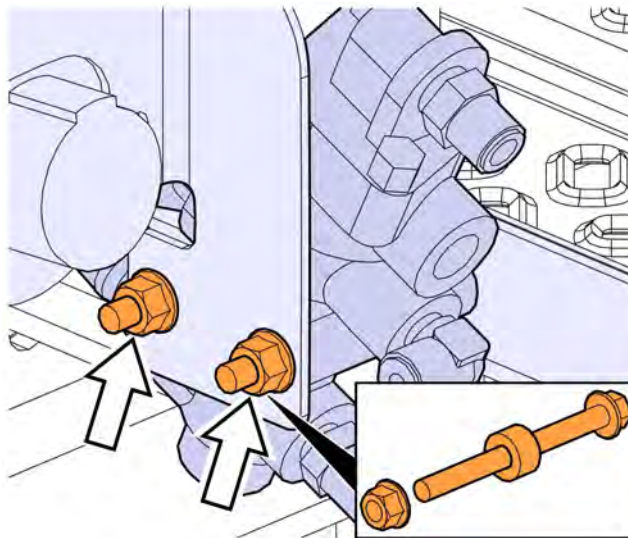

W5095216

- 9 Position the tractor protection valve to gain access to the DC-4 double check valve.
- 10 Remove the DC-4 double check valve from the tractor protection valve.

Note: Note the position of the existing valve and fittings for installation purposes.

Note: Discard the valve and fittings.

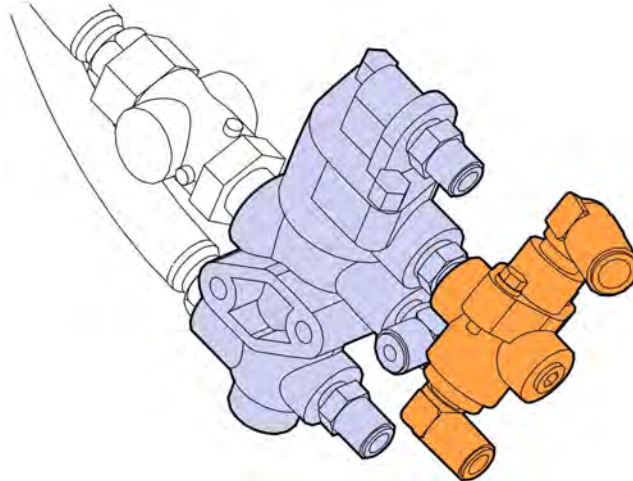

W5095220

- 11 Remove the union fitting (1) and tube fitting (2) from the tractor protection valve.

Note: Discard the fittings.

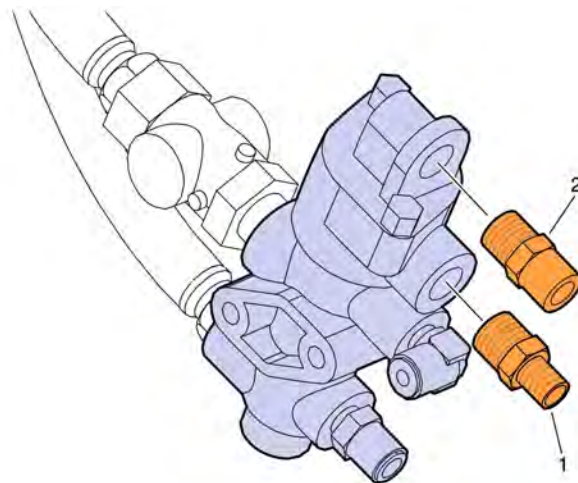

W5095222

- 12 Apply thread sealant to union fitting (7) and install it onto the tractor protection valve.
- 13 Apply thread sealant to air brake fitting (5) or (6) and install it onto the tractor protection valve.

Note: For appropriate selection of the air brake fitting, see the table below.

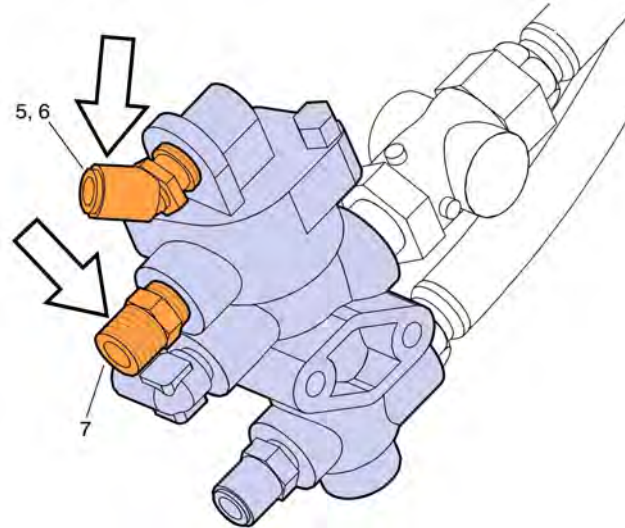

W5095226

Air Brake Fitting Selection			
Item	Description	Part Number	Qty
5	Fitting, 12,7*3/8 NPTF (ESP-BAS1 Variant)	8397715	1
6	Fitting, 9.5*3/8 NPTF (UESP Variant)	8397714	1

- 14 Using thread sealant, install the fittings and plug onto the replacement QR-1 quick release valve (part number 20812943).

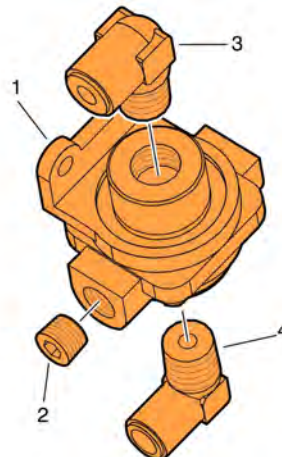

W5095224

15 Using thread sealant, install the QR-1 quick release valve assembly onto the tractor protection valve.

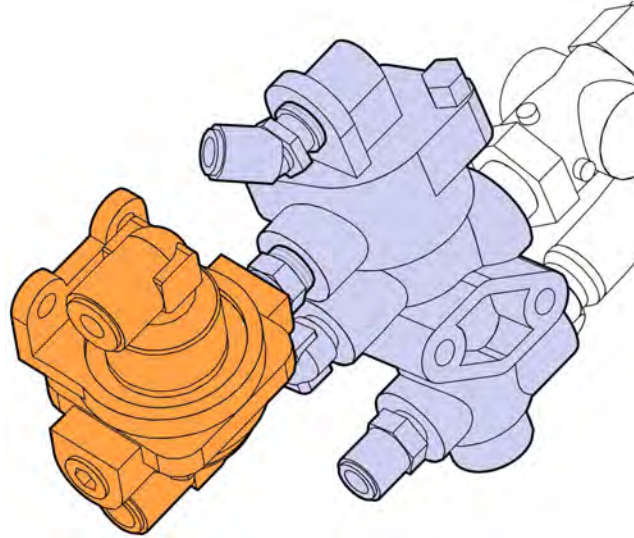

W5095227

16 Position the tractor protection valve and the trailer electrical receptacle bracket to the truck cross member.

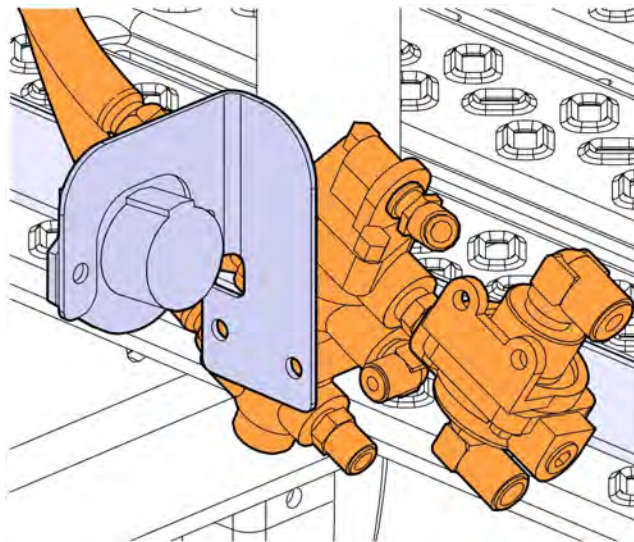

W5095228

- 17 Install the fasteners and spacers securing the valve assembly and bracket to the truck cross member.
- 18 Tighten the fasteners to 12.5 ± 2.2 Nm (17 ± 3 ft-lb).

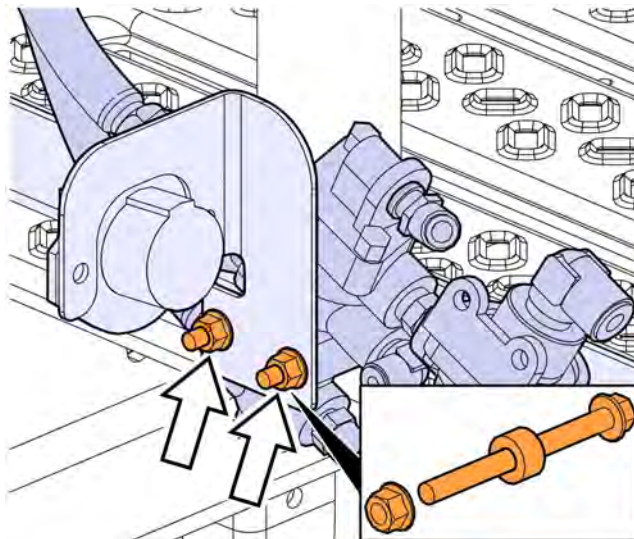

W5095229

- 19 Connect the previously removed air lines.

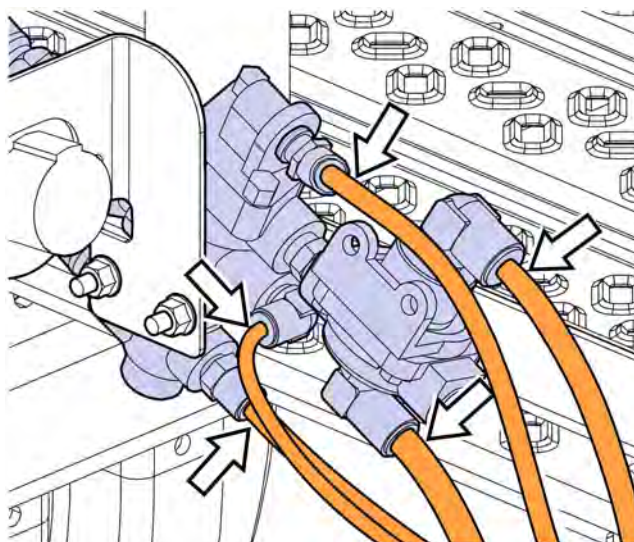

W5095230

20 Connect the battery cable to the negative (ground) terminal.

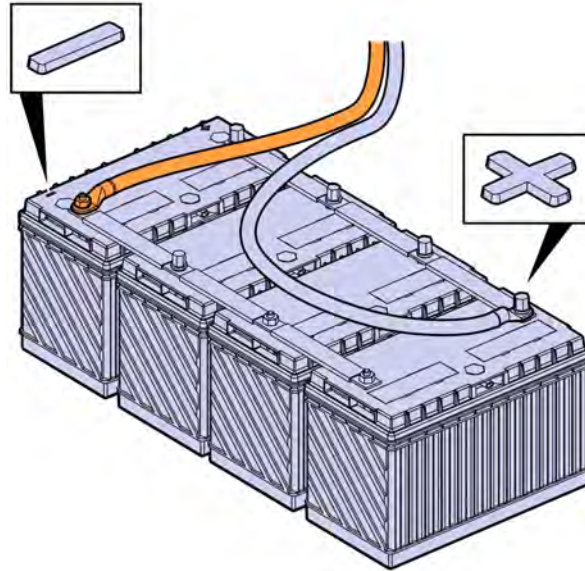

W3086758

21 Start the truck, build up air pressure and check for air leaks during normal operation pressure.

22 Remove the wheel chocks.

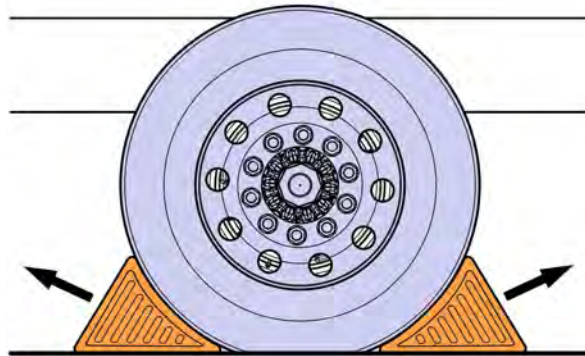

W7086759

Reimbursement

This repair may be eligible for reimbursement if a product failure was experienced within time and mileage limits of the applicable Warranty coverage. Reimbursement is obtained via the normal claim handling process.	UCHP Reimbursement	eWarranty Reimbursement
Claim Type (used only when uploading from the Dealer Bus. Sys.)	01	01
Labor Code		
Primary Labor Code (Grade Gripper Quick Release Valve, Replacement)	5939-03-09-03 0.5 hrs.	F332F-01-80 0.5 hrs.
Causal Part	25110484	25110484

MACK Trucks North America reserves the right to make any changes in design or to make additions to or upon its products without incurring any obligations to install the same on vehicles previously built.