



# Service Bulletin



## SERVICE UPDATE

**SUBJECT:** Service Update for Inventory and Customer Vehicles  
Power Steering Hose Leak  
Expires with Base Warranty

**MODELS:** 2015 Chevrolet Silverado 2500/3500 HD  
2015 GMC Sierra 2500/3500 HD  
Serviced Before September 9, 2014 (Pursuant to Recall Bulletin 14356)

This service update includes vehicles in dealer inventory and customer vehicles that return to the dealership for any reason. This bulletin will expire at the end of the involved vehicle's New Vehicle Limited Warranty period.

### PURPOSE

This bulletin provides a further service procedure to inspect vehicles and replace the power steering cooler assembly as needed on certain 2015 model year Chevrolet Silverado 2500/3500 HD and GMC Sierra 2500/3500 HD vehicles that were previously serviced prior to September 9, 2014 pursuant to recall bulletin 14356 (since superseded by bulletin 14356A). These vehicles may have been built with a hose connection within the power steering cooler assembly that is missing the ferrule or ferrule crimp. If the vehicle is driven without the ferrule or ferrule crimp, there may be a loss of power steering fluid.

**This service procedure should be completed as soon as possible on involved vehicles currently in dealer inventory and customer vehicles that return to the dealer for any type of service during the New Vehicle Limited Warranty coverage period.**

### VEHICLES INVOLVED

All involved vehicles are identified by VIN in the Global Warranty Management System – Investigate Vehicle History Application. Dealership technicians should always check this site to confirm vehicle involvement prior to beginning any required inspections and/or repairs. It is important to routinely use this tool to verify eligibility because not all similar vehicles may be involved regardless of description or option content.

Additionally, a list of involved vehicles currently in dealer inventory is available on the “Service Update Bulletin Information” link under the “Service” tab in GM GlobalConnect (US) or attached to the GlobalConnect message (Canada) used to release this bulletin. Customer vehicles that

return for service, for any reason, and are still covered under the vehicle's base warranty should also be checked for vehicle eligibility.

### PART INFORMATION

Parts required to complete this service update are to be obtained from General Motors Customer Care and Aftersales (GMCCA). Please refer to your "involved vehicles listing" before ordering parts. Normal orders should be placed on a DRO = Daily Replenishment Order. In an emergency situation, parts should be ordered on a CSO = Customer Special Order.

Part Number	Description	Quantity/Vehicle
23443831	Cooler, Power Steering Fluid - Diesel	1 (if req'd)
22808954	Cooler, Power Steering Fluid - Gas	1 (if req'd)
89021182	GM Power Steering Fluid 32 oz.(Use With Cooler Replacement Only, See Net Item For Inspection Material Allowance)	1 (if req'd)

### SERVICE PROCEDURE

Use the following steps to inspect the power steering cooler hoses. Check for fluid leaks and loose, missing, or un-crimped metal ferrules on the power steering cooler hose assembly.



3975435

(A) Crimped ferrule with swedge marks. This is a secure connection on the pipe ferrule. (B) Uncrimped ferrule without swedge marks. This is NOT a secure connection on the pipe ferrule.

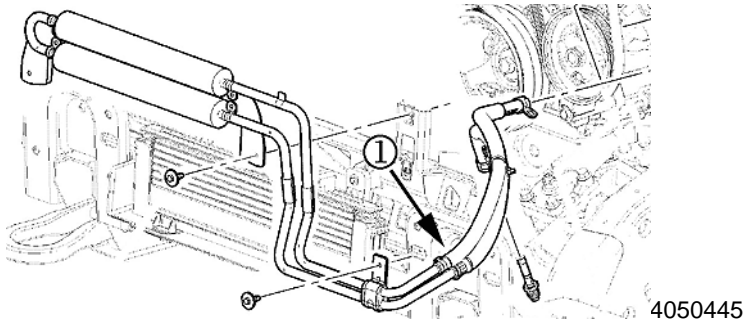

Gas engine shown – Diesel similar

1. Open the hood and locate the section of the power steering cooler lines where the rubber hoses join the metal pipes (1).
2. Verify there is a metal collar (ferrule) on the both rubber hoses where they join the metal pipes.
3. Verify that both ferrules are crimped and display the swedge mark. Pull on the crimped end of the hose to determine if hose crimp is loose (not secure) on the pipe ferrule.
  - If the power steering hose crimps are secure and show evidence of swedge marks AND the power steering hose clamps are engaged at both the power steering pump and gear locations, no further action is required. Refer to *Power Steering Fluid Leaks* in SI to diagnose any fluid leaks.
  - If the power steering hose is missing a ferrule, the crimps are NOT secure or DO NOT show evidence of swedge marks, **replace the power steering fluid cooler**. Refer to *Power Steering Fluid Cooler Replacement (Heavy Duty)* in SI.
2. Check and, if necessary, add power steering fluid to the power steering system. Refer to *Checking and Adding Power Steering Fluid* in SI.
3. Check the system for the presence of air. Refer to *Power Steering System Bleeding* in SI.

#### WARRANTY TRANSACTION INFORMATION

Submit a transaction using the table below. All transactions should be submitted as a ZFAT transaction type, unless noted otherwise.

Labor Code	Description	Labor Time	Net Item
9101176	Inspect Power Steering Hoses (Gasoline Engine)	0.3	*
9101177	Inspect Power Steering Hoses (Diesel Engine)	0.4	*
9101178	Replace Power Steering Fluid Cooler – Includes Inspection (Gasoline Engine)	4.9	N/A
9101179	Replace Power Steering Fluid Cooler – Includes Inspection (Diesel Engine)	5.0	N/A

\* The amount identified in "Net Item" should represent the actual sum total of the current GMCCA dealer net price for contact cleaner needed to clean the area of fluid seepage/leakage and for power steering fluid needed to top-off the power steering fluid level when required, not to exceed \$10.00 USD, \$11.60 CDN plus applicable Mark-Up or Landed Cost (for Export).

#### DEALER PROGRAM RESPONSIBILITY

Whenever a vehicle subject to this service update enters your vehicle inventory, or is in your facility for service in the future, and the vehicle is still covered under the New Vehicle Limited Warranty, you must take the steps necessary to be sure the service update correction has been made before selling or releasing the vehicle.



GM CUSTOMER CARE AND AFTERSALES  
DCS3484  
URGENT - DISTRIBUTE IMMEDIATELY

Date: December 22, 2014

Subject: 14608 – Service Update for Inventory and Customer Vehicles -  
Power Steering Hose Leak

Models: 2015 Chevrolet Silverado 2500/3500 HD  
2015 GMC Sierra 2500/3500 HD

To: All Chevrolet and GMC Dealers

Attention: General Manager, Service Advisor, Service Manager, Parts and  
Service Director, Parts Manager, New Vehicle Sales Manager,  
and Warranty Administrator

General Motors is releasing Service Update Bulletin 14608 today. The total number of U.S. vehicles involved is approximately 30,200. Please see the attached bulletin for details. A VIN List of US vehicles in stock is attached to this message assorted by BAC code.

**Global Warranty Management (GWM)**

The "Investigate Vehicle History" (IVH) screen will be updated December 23, 2014.

END OF MESSAGE  
GM CUSTOMER CARE AND AFTERSALES