



# Service Bulletin



## SPECIAL COVERAGE

**SUBJECT: Special Coverage Adjustment – Loss of Power Steering Assist**

**MODELS: 2008-2011 Buick Enclave  
2009-2011 Chevrolet Traverse  
2007-2011 GMC Acadia  
2007-2010 Saturn OUTLOOK**

The service procedure has been revised to assist dealers in diagnosing the described condition. Please discard all copies of bulletin 14329.

### CONDITION

Some 2008-2011 model year (MY) Buick Enclave, 2009-2011 MY Chevrolet Traverse, 2007-2011 MY GMC Acadia, and 2007-2010 MY Saturn OUTLOOK vehicles may develop a power steering pump wear condition that can cause an intermittent drop of power steering hydraulic pressure that will cause reduced or loss of steering assist. The vehicle may revert to manual steering which requires greater driver effort, particularly at low vehicle speeds.

### SPECIAL COVERAGE ADJUSTMENT

This special coverage covers the condition described above for a period of 10 years or 150,000 miles (240,000 km), whichever occurs first, from the date the vehicle was originally placed in service, regardless of ownership.

Dealers are to flush the power steering system, replace the power steering pump, and if it hasn't already been replaced, install a new steering gear valve housing. The repairs will be made at no charge to the customer.

For vehicles covered by Vehicle Service Contracts, all eligible claims with repair orders on or after September 5, 2014, are covered by this special coverage and must be submitted using the labor operation codes provided with this bulletin. Claims with repair orders prior to September 5, 2014, must be submitted to the Service Contract provider.

### VEHICLES INVOLVED

All involved vehicles are identified by Vehicle Identification Number on the Applicable Warranties section in GM Global Warranty Management system. Dealership service personnel should always check this site to confirm vehicle involvement prior to beginning any required inspections

and/or repairs. It is important to routinely use this tool to verify eligibility because not all similar vehicles may be involved regardless of description or option content.

### PART INFORMATION

Parts required to complete this special coverage are to be obtained from General Motors Customer Care and Aftersales (GMCC&A).

Part Number	Description	Quantity/Vehicle
<b>Parts for Power Steering Pump Only Replacement</b>		
20954812	Pump, Power Steering	1
88861037	DEXRON-VI Fluid (w/o steering gear kit)	3
<b>Additional Parts Req'd if Steering Gear Housing Requires Replacing</b>		
88861037	DEXRON-VI Fluid (with steering gear kit)	5
22847734	Kit, Steering Gear Hsg (w/RPO NV7)	1
22847735	Kit, Steering Gear Hsg. (w/o RPO NV7)	1
11609933	Bolt, Front Frame Front Mounting	2
11609932	Bolt, Front Frame Rear Mounting	2

### SERVICE PROCEDURE

Note: Check the power steering fluid level before evaluating or diagnosing the system and adjust as necessary. Low fluids may demonstrate a similar concern and any leaks in the system causing low fluid level should be brought to the attention of the customer, but it is not covered under this special coverage. Steering gear boot staining does not necessarily indicate a sign of leakage and should be evaluated as per TSB 12-02-32-004A.

- Verify the conditions under which the customer may be experiencing the intermittent loss of assist, confirming that it is occurring at slow speed maneuvers or at low engine RPM driving. If the condition is present at the time of diagnosis, **it should be present between 1800 and 2000 rpm. Raise engine speed to this RPM band with the vehicle in gear and turn the steering wheel to duplicate the concern.** If the loss of assist is present at idle or in conditions at higher vehicle speed, refer to the appropriate diagnostic information in SI for further diagnosis of the system.
  - If the power steering pump does NOT require replacement, no further action is required. Inform the customer that any additional diagnosis and repairs are not covered under this special coverage.
  - If the condition can be duplicated or if the conditions under which the customer is experiencing the intermittent loss of assist agrees with the conditions mentioned above, the power steering pump requires replacement, proceed to the next step.

**Note:** Check the vehicle history before beginning repairs. Ensure that the vehicle has been updated to DEXRON®-VI fluid. This is fluid replacement usually takes place when performing PI 0620 and/or PI0029. Examining the fluid is also recommended to determine if the system has been convert to DEXRON®-VI. The DEXRON®-VI fluid is red in color, the original fluid is light brown in color. If after examining the fluid color and condition, it cannot be determined if the fluid has been updated or if it is possible to confirm the fluid has not been updated, see the *Installing New Steering Gear Housing Kit and Fluid* section below.

2. Replace the power steering pump and fluid. Refer to *Power Steering Pump Replacement in SI*.

**Caution:** Due to the interface between the pinion shaft seal and the fluid, it is critical to ensure that no old fluid comes in contact with the new seal (the new seal is included with the Steering Gear Housing Kit). Be sure to thoroughly flush all old fluid from the system prior to installing the new housing.

### Installing New Steering Gear Housing Kit and Fluid

If the fluid has not been updated to DEXRON®-VI fluid, the following steps must be performed in addition the pump replacement procedure. The new steering gear housing kit will include either a tag or an owner's manual insert that identifies the vehicle has been converted to DEXRON®-VI. If the kit includes the tag, it should be installed on the power steering reservoir filler neck and secured with the cap. If the kit includes the insert, it should be placed in the vehicle owner's manual in the appropriate section. Also, please advise the customer that their vehicle has been converted to DEXRON®-VI.

1. Flush the power steering system with DEXRON®-VI Automatic Transmission Fluid.
2. Raise and support the vehicle until the wheels are approximately 61 cm (24 in) off the ground.
3. Place a large container under the vehicle in order to collect the draining fluid.

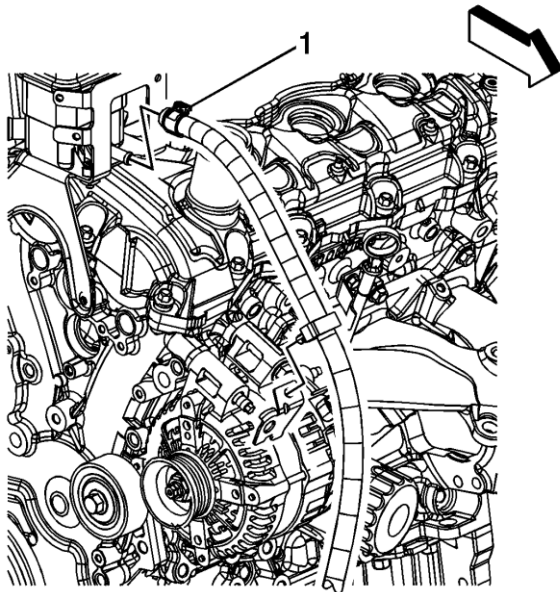

1856010

4. Loosen the hose clamp (1) and disconnect the power steering fluid reservoir inlet hose from the power steering fluid reservoir.
5. Plug the power steering fluid reservoir inlet port.

**Note:** This step may require 3L (3 qt) of DEXRON®-VI fluid until the draining fluid appears red.

6. With the key ON and the engine OFF, turn the steering wheel fully to the left and to the right while an assistant maintains the minimum fluid level in the reservoir using DEXRON®-VI Automatic Transmission Fluid. Continue until the fluid from the power steering fluid reservoir inlet hose runs red.
7. Remove the plug from the power steering fluid reservoir inlet port.
8. Connect the power steering fluid reservoir inlet hose to the reservoir and secure the hose with the clamp.

9. Raise and support the vehicle.
10. Remove the intermediate steering shaft bolt and separate the intermediate steering shaft from the steering gear.
11. Position adjustable jack stands underneath the left and right sides of the vehicle at the rear of the front frame.

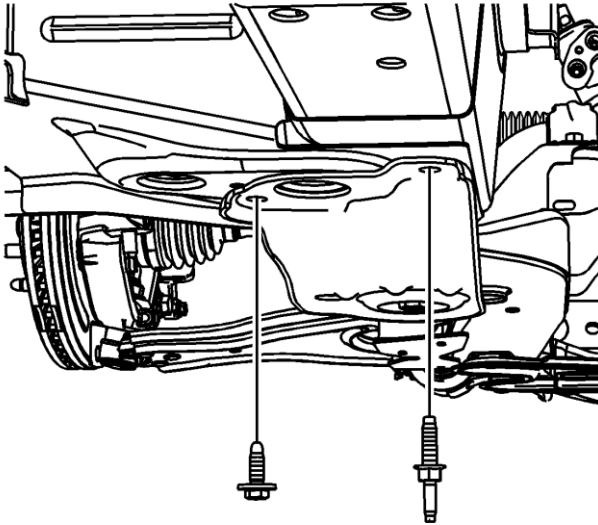

1856440

12. Remove the left and right front frame reinforcement mounting bolts. The left side is shown. The right side is similar.

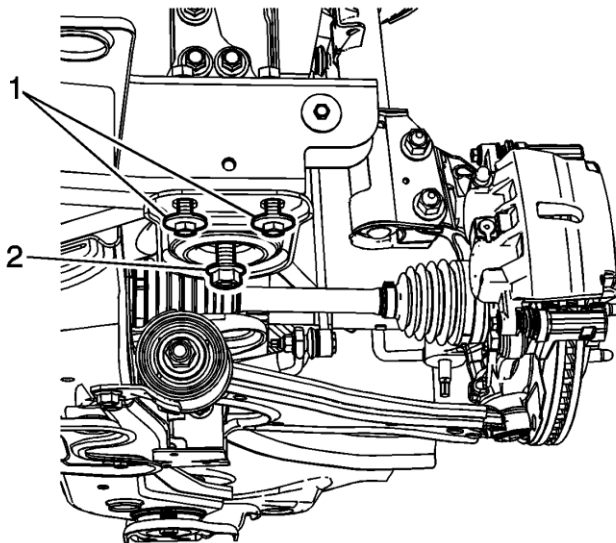

1856458

13. Loosen the front frame reinforcement mounting bolts (1). The left side is shown. The right side is similar.
14. Loosen the front frame mounting bolts (2). The left side is shown. The right side is similar.

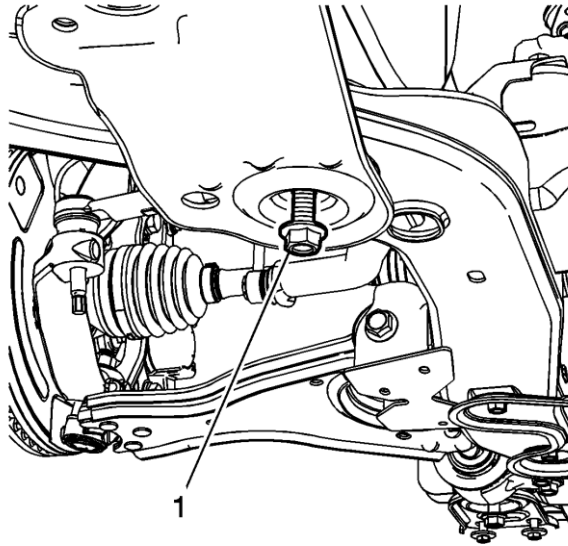

1856464

15. Loosen the front frame rear mounting bolts (1).
16. Lower the frame from the frame rail until enough clearance is gained to remove the steering gear housing.
17. Remove the steering gear heat shield.

**Caution:** A rapid jerking condition of the steering wheel may occur if the steering gear transfer tubes are incorrectly installed.

18. Remove both steering gear transfer tubes. Mark the location of the transfer tubes so they can be reinstalled in the same position.

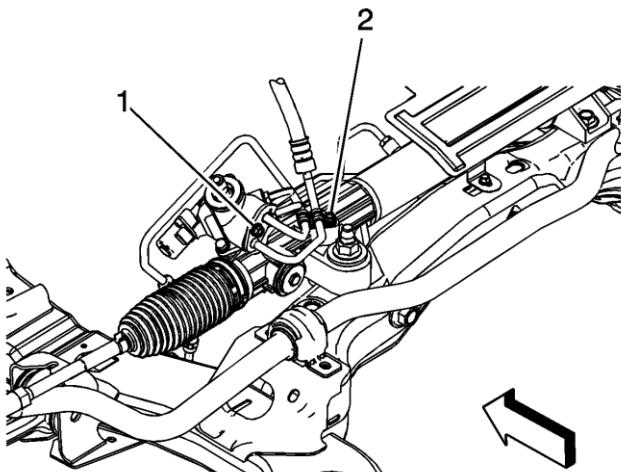

1861303

19. Remove the power steering gear inlet hose retaining plate bolt (1).
20. Disconnect the power steering gear inlet and outlet hoses from the steering gear.
21. Remove the power steering gear inlet and outlet pipe clip bolt (2).

22. Separate the power steering gear inlet and outlet hoses from the power steering gear inlet and outlet pipe clip.
23. Disconnect the electrical connector from the steering gear valve solenoid, if equipped with Variable Effort Steering (RPO NV7).
24. Clean the area around the steering gear housing to prevent any debris from entering the gear once the housing is removed.

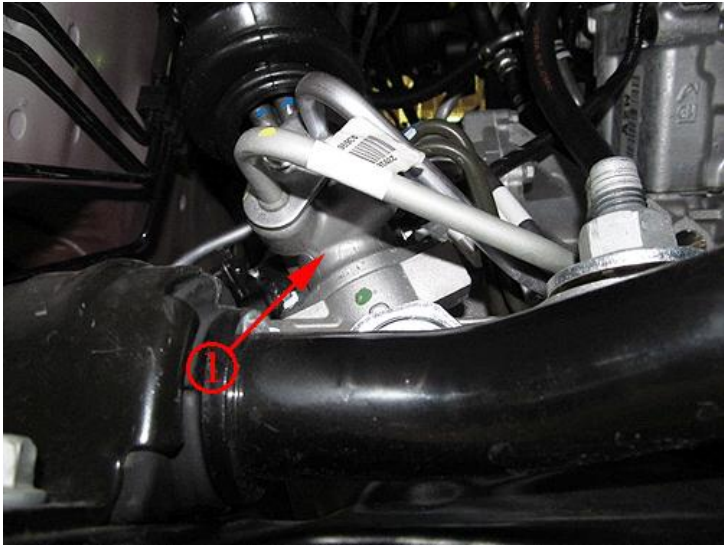

2691990

25. Remove the steering gear housing bolts and housing (1) from the steering gear.
26. Transfer the steering gear valve solenoid to the new housing, if equipped with Variable Effort Steering (RPO NV7).
27. Remove the steering gear solenoid valve bolts and valve.
28. Remove and discard the three O-ring seals.
29. Install the new O-ring seals provided in the kit.
30. Install the steering gear valve and secure with bolts.

**Tighten**

Tighten the steering gear solenoid valve bolts to 8 N.m (71 lb in).

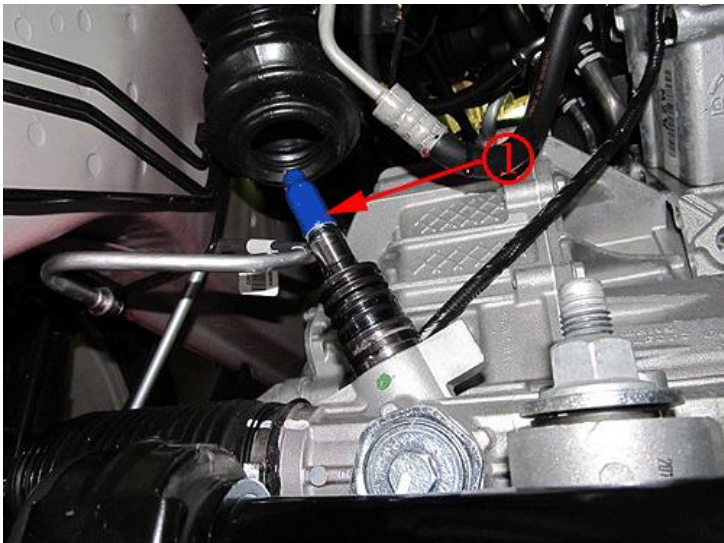

2691992

31. Install the blue seal protector (1) provided in kit onto the steering gear pinion shaft to prevent damage to the seal when installing the housing.
32. Install the new steering gear housing and bolts to the steering gear. Remove the seal protector.

**Tighten**

Tighten the housing bolts to 21 N.m (16 lb ft).

33. Connect the electrical connector to the steering gear valve solenoid, if equipped with Variable Effort Steering (RPO NV7).
34. Install the power steering gear inlet and outlet hoses to the steering gear.

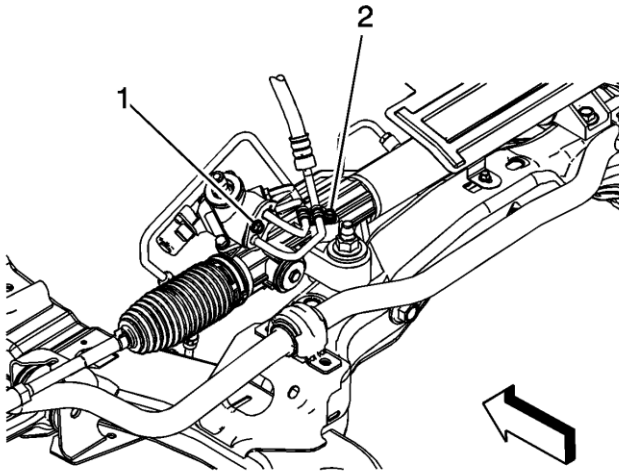

1861303

35. Install the power steering gear inlet hose retaining plate bolt (1).

**Tighten**

Tighten the bolts to 21 N.m (16 lb ft).

36. Install the power steering gear inlet and outlet hoses to the power steering gear inlet and outlet pipe clip.
37. Install the power steering gear inlet and outlet pipe clip bolt (2).

**Note:** Be sure to install the transfer lines in the correct location. The longer transfer line should be assembled to the upper hole on the steering gear and the shorter line assembled to the lower hole.

38. Install both transfer tubes to the steering gear. Use new O-ring seals provided in kit.

**Tighten**

Tighten the tube nuts to 15 N.m (133 lb in).

39. Install the steering gear heat shield.
40. Raise the front frame to the vehicle body leaving a gap of approximately 12 mm (0.5 in).

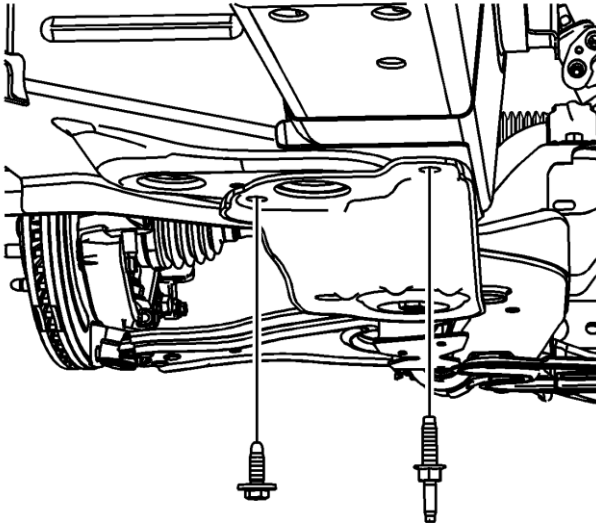

1856440

41. Install the left and right front frame reinforcement mounting bolts. The left side is shown. The right side is similar.

**Tighten**

Tighten the bolts to 50 N.m (37 lb ft).

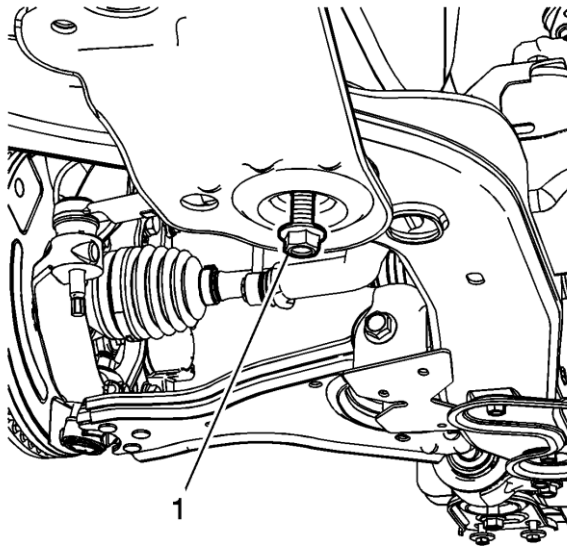

1856464

42. Install the NEW front frame rear mounting bolts (1).

**Tighten**

Tighten the bolts to 100 N.m (74 lb ft). Tighten the bolts an additional 90 degrees.



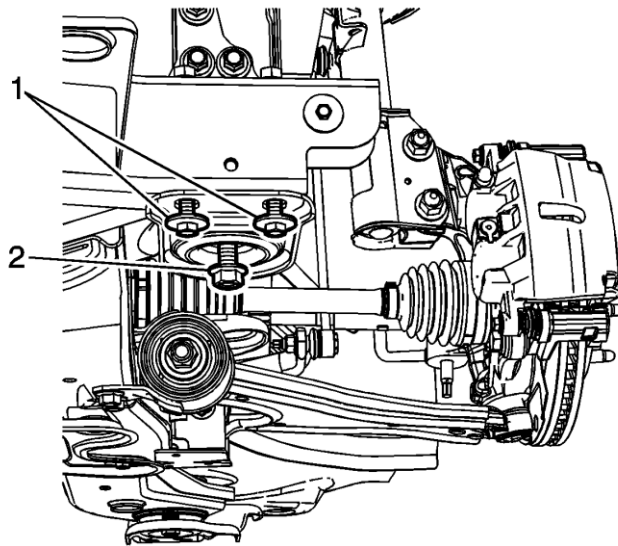

1856458

43. Install the NEW front frame mounting bolts (2). The left side is shown. The right side is similar.

**Tighten**

- a. Tighten the bolts to 100 N.m (74 lb ft).
  - b. Tighten the bolts an additional 90 degrees.
44. Remove the adjustable jack stands from underneath the vehicle.
45. Install the intermediate steering shaft to the steering gear and install the intermediate steering shaft bolt.
46. Fill and bleed the power steering system. Refill with DEXRON®-VI Automatic Transmission Fluid, Refer to the *Power Steering System Bleeding* procedure in SI.
47. Ensure there are no power steering fluid leaks.
48. Lower the vehicle.

**CUSTOMER REIMBURSEMENT - For US**

Customer requests for reimbursement of previously paid repairs to correct the condition described in this bulletin are to be submitted to the dealer by September 30, 2015, unless otherwise specified by state law. If this is not convenient for the customer, they may mail the completed Customer Reimbursement Request Form and all required documents to the GM Customer Assistance Center. Repairs must have occurred within the 10 years of the date the vehicle was originally placed in service, or 150,000 miles, whichever occurs first.

**All reasonable and customary costs to correct the condition described in this bulletin should be considered for reimbursement. Any questions or concerns should be reviewed with your GM representative prior to processing the request.**

When a customer requests reimbursement, they must provide the following:

- A completed Customer Reimbursement Request Form. This form is mailed to the customer or can be obtained through GM GlobalConnect.
- The name and address of the person who paid for the repair.

- Paid receipt confirming the amount of the repair expense, a description of the repair, and the person or entity performing the repair.

**IMPORTANT:** GM requires dealers to approve or deny a reimbursement request within 30 days of receipt. If a reimbursement request is approved, the dealer should immediately issue a check to the customer and submit an appropriate warranty transaction for the incurred expense. If a reimbursement request is denied, the dealer MUST provide the customer with a clear and concise explanation, in writing, as to why the request was denied. The bottom portion of the Customer Reimbursement Request Form may be used for this purpose. If the denial was due to missing documents, the customer can resubmit the request when the missing documents are obtained, as long as it is still within the allowed reimbursement period.

Warranty transactions for customer reimbursement of previously paid repairs are to be submitted as required by GM Global Warranty Management. Additional information can also be found in Warranty Administration Bulletin 11-00-89-004.

#### CUSTOMER REIMBURSEMENT - For Canada and Export

Customer requests for reimbursement of previously paid repairs to correct the condition described in this bulletin are to be submitted to the dealer prior to or by September 30, 2015. Repairs must have occurred within the 10 years of the date the vehicle was originally placed in service, or 240,000 kilometers, whichever occurs first.

When a customer requests reimbursement, they must provide the following:

- Proof of ownership at time of repair.
- Original paid receipt confirming the amount of unreimbursed repair expense(s) (including Service Contract deductibles), a description of the repair, and the person or entity performing the repair.

All reasonable and customary costs to correct the condition described in this bulletin should be considered for reimbursement. Any questions or concerns should be reviewed with your GM representative prior to processing the request.

#### COURTESY TRANSPORTATION – For US and Canada

The General Motors Courtesy Transportation program is intended to minimize customer inconvenience when a vehicle requires a repair that is covered by the New Vehicle Limited Warranties. The availability of courtesy transportation to customers whose vehicles are within the warranty coverage period and involved in a product program is very important in maintaining customer satisfaction. Dealers are to ensure that these customers understand that shuttle service or some other form of courtesy transportation is available and will be provided at no charge. Dealers should refer to the General Motors Service Policies and Procedures Manual for Courtesy Transportation guidelines.

**WARRANTY TRANSACTION INFORMATION**

Submit a transaction using the table below. All transactions should be submitted as a ZREG transaction type, unless noted otherwise.

<b>Labor Code</b>	<b>Description</b>	<b>Labor Time</b>	<b>Net Item</b>
9900052	Diagnostic Time Only – No Repair Required	0.1-0.3	N/A
9900053	Power Steering Pump Replacement (inc. system bleed) - FWD - AWD Add: Install Steering Gear Housing Kit (inc. flush & system bleed) Add: Diagnostic Time	2.3 4.7 1.5 0.1-0.3	N/A
9900054	Customer Reimbursement Approved	0.2	*
9900055	Customer Reimbursement Denied - For US dealers only	0.1	N/A

\* The amount identified in “Net Item” should represent the dollar amount reimbursed to the customer.

**CUSTOMER NOTIFICATION**

General Motors will notify customers of this special coverage on their vehicles (see copy of typical customer letter included with this bulletin - actual divisional letter may vary slightly).



September 2014

Dear General Motors Customer:

As the owner of a 2008-2011 model year (MY) Buick Enclave, 2009-2011 MY Chevrolet Traverse, 2007-2011 MY GMC Acadia, or 2007-2010 MY Saturn OUTLOOK, your satisfaction with our product is very important to us.

This letter is intended to make you aware that some 2008-2011 model year (MY) Buick Enclave, 2009-2011 MY Chevrolet Traverse, 2007-2011 MY GMC Acadia, and 2007-2010 MY Saturn OUTLOOK vehicles may develop a power steering pump wear condition that can cause an intermittent drop of power steering hydraulic pressure that will cause reduced or loss of steering assist. The vehicle may revert to manual steering which requires greater driver effort, particularly at low vehicle speeds.

**Do not take your vehicle to your GM dealer as a result of this letter unless you believe that your vehicle has the condition as described above.**

**What We Have Done:** General Motors is providing owners with additional protection for the condition described above. If this condition occurs on your 2008-2011 model year (MY) Buick Enclave, 2009-2011 MY Chevrolet Traverse, 2007-2011 MY GMC Acadia, or 2007-2010 MY Saturn OUTLOOK within 10 years of the date your vehicle was originally placed in service or 150,000 miles (240,000 km), whichever occurs first, the condition will be repaired for you at **no charge**. Diagnosis or repair for conditions other than the condition described above is not covered under this special coverage program.

**What You Should Do:** If you believe that your vehicle has the condition described above, repairs and adjustments qualifying under this special coverage must be performed by a General Motors dealer. You may want to contact your GM dealer to find out how long they will need to have your vehicle so that you may schedule the appointment at a time that is convenient for you. This will also allow your dealer to order parts if they are not already in stock. Keep this letter with your other important glove box literature for future reference.

**Reimbursement:** If you have paid for repairs for the condition described in this letter, please complete the enclosed reimbursement form and present it to your dealer with all required documents. Working with your dealer will expedite your request, however, if this is not convenient, you may mail the completed reimbursement form and all required documents to Reimbursement Department, PO Box 33170, Detroit, MI 48232-5170. The completed form and required documents must be presented to your dealer or received by the Reimbursement Department by September 30, 2015, unless state law specifies a longer reimbursement period.

If you have any questions or need any assistance, just contact your dealer or the appropriate Customer Assistance Center at the number listed below.

Division	Number	Text Telephones (TTY)
Buick	1-800-521-7300	1-800-832-8425
Chevrolet	1-800-222-1020	1-800-833-2438
GMC	1-800-462-8782	1-888-889-2438
Saturn	1-800-553-6000	1-800-833-6000
Guam	65-6267-1752	
Puerto Rico – English	1-800-496-9992	
Puerto Rico – Español	1-800-496-9993	

Virgin Islands	1-800-496-9994	
----------------	----------------	--

We are sorry for any inconvenience you may experience; however, we have taken this action in the interest of your continued satisfaction with our products.

Jim Moloney  
General Director,  
Customer and Relationship Services

Enclosure  
14329

GM CUSTOMER CARE AND AFTERSALES  
DCS3475  
URGENT - DISTRIBUTE IMMEDIATELY

Date: December 10, 2014

Subject: 14329A – Special Coverage Adjustment  
Loss of Power Steering Assist  
Revised Service Procedure

Models: 2008-11 Buick Enclave; 2009-11 Chevrolet Traverse;  
2007-11 GMC Acadia; 2007-10 Saturn OUTLOOK

To: All GM Dealers

Attention: General Manager, Service Advisor, Service Manager, Parts and  
Service Director, Parts Manager, Used Vehicle Sales Manager,  
and Warranty Administrator

The service procedure has been revised to assist dealers in diagnosing the  
described condition. Please discard all copies of bulletin 14329.

END OF MESSAGE  
GM CUSTOMER CARE AND AFTERSALES