



Program Bulletin



CUSTOMER SATISFACTION PROGRAM

SUBJECT: Transmission 2-6 Clutch Pack Misbuilt

MODELS: 2013 Chevrolet Camaro Coupe
Equipped with 3.6L V-6 Engine (LFX) and 6L50 6-Speed Automatic
Transmission (MYB)

The Part Information section in this bulletin has been revised. Transmissions are now available through GMCCA. Please discard all copies of bulletin 13332.

Vehicles involved in this customer satisfaction program were placed on stop delivery September 27, 2013. Completion of the service procedure contained in this bulletin will release the vehicle from stop delivery and allow a dealer to deliver the vehicle to a customer.

An analysis of transmission build data revealed that there could be a build concern that may cause drivability issues with the transmissions originally installed in these vehicles. To ensure the highest quality and best ownership experience for our customers, these transmissions need to be replaced prior to vehicle delivery. In the interest of full disclosure, dealer must inform the customer of the transmission repair before the customer purchases the vehicle. Some states and provinces also have laws or regulations requiring disclosure. A written acknowledgement of this pre-delivery repair from the customer is strongly recommended.

.....
THIS PROGRAM IS IN EFFECT UNTIL NOVEMBER 30, 2015.
.....

CONDITION

Certain 2013 model year Chevrolet Camaro Coupe vehicles equipped with a 3.6L V-6 engine (LFX) and a 6L50 6-speed automatic transmission (MYB) may have a transmission 2-6 clutch pack that was misbuilt. This could result in a rattle noise and reduced transmission torque capacity. If this occurs, a diagnostic code may be set and a MIL may be illuminated. In addition, the transmission may be limited to the 3rd or 5th gear, however, reverse gear will still be available.

CORRECTION

Dealers are to replace the transmission.

VEHICLES INVOLVED

All involved vehicles are identified by Vehicle Identification Number on the Investigate Vehicle History screen in GM Global Warranty Management system. Dealership service personnel should always check this site to confirm vehicle involvement prior to beginning any required inspections and/or repairs. It is important to routinely use this tool to verify eligibility because not all similar vehicles may be involved regardless of description or option content.

For dealers with involved vehicles, a listing with involved vehicles containing the complete vehicle identification number, customer name, and address information has been prepared and will be provided to US and Canadian dealers through the GM GlobalConnect Recall Reports. Dealers will not have a report available if they have no involved vehicles currently assigned.

The listing may contain customer names and addresses obtained from Motor Vehicle Registration Records. The use of such motor vehicle registration data for any purpose other than follow-up necessary to complete this program is a violation of law in several states/provinces/countries. Accordingly, you are urged to limit the use of this report to the follow-up necessary to complete this program.

PART INFORMATION

Parts required to complete this service update are to be obtained from GMCCA. Please refer to your "involved vehicles listing" before ordering parts. Normal orders should be placed on a DRO = Daily Replenishment Order. In an emergency situation, parts should be ordered on a CSO = Customer Special Order.

Part Number	Description	Quantity/Vehicle
19302148	Transmission, Auto	1
88861037 - US 19264717 - CA	DEXRON®-VI Automatic Transmission Fluid	11
12346290 - US 10953464 - CA	Engine Coolant	2
11517996	Front Pipe Nuts Left & Right Side (4 Per Side)	8
20893953	Exhaust Gasket Left & Right Side (1 Per Side)	2
92228333	Propeller Shaft to Transmission Output Flange Nuts	3
92228335	Propeller Shaft to Drive Pinion Flange Bolts	3
12623461	Heater Inlet and Outlet Pipe Seal	1
12636104	Heater Inlet and Outlet Pipe Gasket	1
12623519	Radiator Outlet Pipe Seal	1
15251488	Seal, Trans Fluid Cooler Pipe Fitting	1
11588468	Torque Converter Bolt	6

SERVICE PROCEDURE

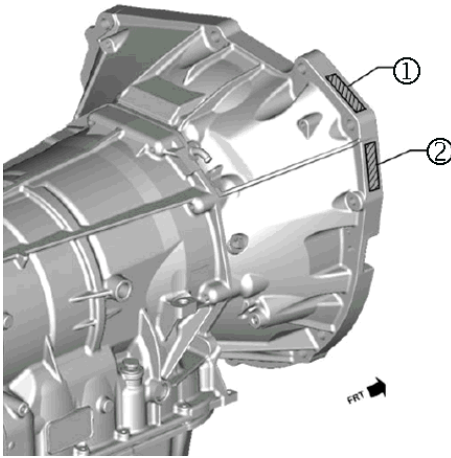

3637589

Note: A VIN derivative is required to be permanently engraved on the new transmission prior to installation. Refer to the illustration above for VIN engraving location points. Select one of the locations to engrave the required characters. VIN derivatives must be formatted as indicated below (# = last eight characters of the VIN).

Chevrolet Camaro: 1H*1#####B

Dealers will be allowed to purchase one engraving tool and attachment as described below.

Name: Dremel Engraver Tool

Manufacturer: Dremel

Model: DRE29001, or equivalent

Attachment: Diamond Point #9929

1. Remove the transmission from the vehicle. Refer to *Transmission Replacement* in SI.
2. Install a new transmission in the vehicle. Refer to *Transmission Replacement* in SI.

FLOOR PLAN REIMBURSEMENT

Dealers in possession of vehicles included in the Stop Delivery are eligible for reimbursement of floor plan expense upon completion of this program. This reimbursement is limited to the number of days from the Stop Delivery message to receipt of the program parts and/or repair procedures. Floor plan reimbursement beyond these dates is not allowed. The amount of reimbursement should be charged as a net amount expense using the program labor operation provided.

COURTESY TRANSPORTATION – For US and Canada

The General Motors Courtesy Transportation program is intended to minimize customer inconvenience when a vehicle requires a repair that is covered by the New Vehicle Limited Warranties. The availability of courtesy transportation to customers whose vehicles are within the warranty coverage period and involved in a product program is very important in maintaining customer satisfaction. Dealers are to ensure that these customers understand that shuttle

service or some other form of courtesy transportation is available and will be provided at no charge. Dealers should refer to the General Motors Service Policies and Procedures Manual for Courtesy Transportation guidelines.

WARRANTY TRANSACTION INFORMATION

Submit a transaction using the table below. All transactions should be submitted as a ZFAT transaction type, unless noted otherwise.

Labor Code	Description	Labor Time	Net Item
9100191	Replace Transmission	4.9	N/A
9100194	Cost of Engraving Tool and Attachment (Only One Per Dealership Allowed)	N/A	*
9100202	Floor Plan Reimbursement	N/A	**

* Submit the actual cost of the engraving tool and attachment, not to exceed \$50.00.

** The amount identified in "Net Item" should represent the product of the vehicle's average daily interest rate (see table below) multiplied by the actual number of days the vehicle was in dealer inventory and not available for sale. This reimbursement is limited to the number of days from the date of the stop delivery message (September 27, 2013) to the date the repair is completed and the vehicle is ready for sale (not to exceed 29 days):

Vehicle	U.S. Reimbursement Amount
Camaro	\$ 4.37

CUSTOMER NOTIFICATION – For US and Canada

General Motors will notify customers of this program on their vehicle (see copy of customer letter included with this bulletin).

DEALER PROGRAM RESPONSIBILITY

All unsold new vehicles in dealers' possession and subject to this program must be held and inspected/repaired per the service procedure of this program bulletin before customers take possession of these vehicles.

Dealers are to service all vehicles subject to this program at no charge to customers, regardless of mileage, age of vehicle, or ownership, through November 30, 2015.

Customers who have recently purchased vehicles sold from your vehicle inventory, and for which there is no customer information indicated on the involved vehicle listing, are to be contacted by the dealer. Arrangements are to be made to make the required correction according to the instructions contained in this bulletin. A copy of the customer letter is provided in this bulletin for your use in contacting customers. Program follow-up cards should not be used for this purpose, since the customer may not as yet have received the notification letter.

In summary, whenever a vehicle subject to this program enters your vehicle inventory, or is in your facility for service through November 30, 2015, you must take the steps necessary to be sure the program correction has been made before selling or releasing the vehicle.



October 2013

Dear General Motors Customer:

Your 2013 model year Chevrolet Camaro Coupe is equipped with a 3.6L V-6 engine and a 6L50 6-speed automatic transmission. We have learned that certain vehicles with this engine-transmission combination may have a transmission 2-6 clutch pack that was misbuilt. This could result in a rattle noise and reduced transmission torque capacity. If this occurs, a diagnostic code may be set and a malfunction indicator lamp may be illuminated. In addition, the transmission may be limited to the 3rd or 5th gear, however, reverse gear will still be available.

Your satisfaction with your Camaro is very important to us, so we are announcing a program to prevent this condition or, if it has occurred, to fix it.

What We Will Do: Your GM dealer will replace your vehicle's transmission. This service will be performed for you at **no charge until November 30, 2015**. After that, any applicable warranty will apply.

What You Should Do: To limit any possible inconvenience, we recommend that you contact your dealer as soon as possible to schedule an appointment for this repair. By scheduling an appointment, your dealer can ensure that the necessary parts will be available on your scheduled appointment date.

Courtesy Transportation: If your vehicle is within the New Vehicle Limited Warranty, your dealer may provide you with shuttle service or some other form of courtesy transportation while your vehicle is at the dealership for this repair. Please refer to your Owner Manual and your dealer for details on Courtesy Transportation.

If you have any questions or concerns that your dealer is unable to resolve, please contact the appropriate Customer Assistance Center at the number listed below.

Division	Number	Text Telephones (TTY)
Chevrolet	1-800-222-1020	1-800-833-2438
Guam	65-6267-1752	
Puerto Rico – English	1-800-496-9992	
Puerto Rico – Español	1-800-496-9993	
Virgin Islands	1-800-496-9994	

We sincerely regret any inconvenience or concern that this situation may cause you. We want you to know that we will do our best, throughout your ownership experience, to ensure that your Camaro provides you many miles of enjoyable driving.

Jim Moloney
General Director,
Customer and Relationship Services

GM CUSTOMER CARE AND AFTERSALES
DCS3416
URGENT - DISTRIBUTE IMMEDIATELY

Date: October 22, 2014

Subject: 13332A – Customer Satisfaction Program
Transmission 2-6 Clutch Pack Misbuilt
Revised Part Information Section

Models: 2013 Chevrolet Camaro Coupe Equipped with 3.6L V6 Engine (LFX)
and 6L50 6-Speed Automatic Transmission (MYB)

To: All Chevrolet Dealers

Attention: General Manager, Service Advisor, Service Manager, Parts and
Service Director, Parts Manager, Used Vehicle Sales Manager,
and Warranty Administrator

The Part Information section has been revised. Transmissions are now available through GMCCA. Please discard all copies of bulletin 13332.

END OF MESSAGE
GM CUSTOMER CARE AND AFTERSALES