



# Service Bulletin

File in Section: -

Bulletin No.: PIC5955

Date: January, 2014

## PRELIMINARY INFORMATION

**Subject:** 4ET50 Electric Drive Unit Service – Rotor B Replacement

**Models:** 2011-2014 Chevrolet Volt  
2014 Cadillac ELR

The following diagnosis might be helpful if the vehicle exhibits the symptom(s) described in this PI.

### Condition/Concern

The proper way to address a Rotor B bearing noise is to perform a bearing only replacement per P/I #PIP5081. This can be done on-car.

If this is a repeat repair, and TAC recommends a Rotor B replacement, this must be done off car per S/I.

### Recommendation/Instructions

When replacing the Rotor B Assembly, it is imperative that the technician follows SI (Document ID: 3641026) exactly step by step. The transmission must be removed from the vehicle. Attempts to try this as an on-car procedure will result in subsequent failures and possible transmission damage. Damage or repeat repairs due to not following publish procedures will not be covered by warranty.

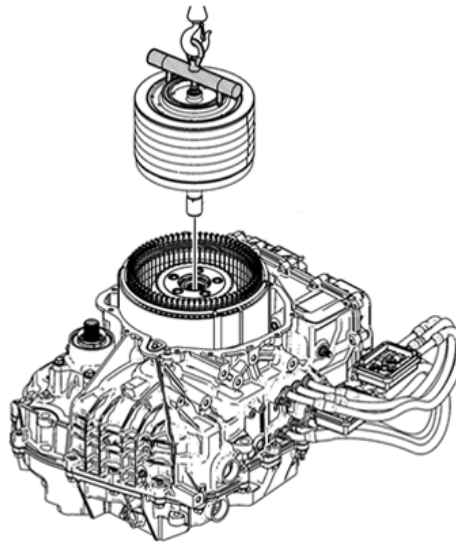

3696546

Please follow this diagnostic or repair process thoroughly and complete each step. If the condition exhibited is resolved without completing every step, the remaining steps do not need to be performed.