

TECHNICAL BULLETIN
Q417 UPS7014-2bNAS1
03 NOV 2014



© Jaguar Land Rover North America, LLC

NOTE: The information in Technical Bulletins is intended for use by trained, professional Technicians with the knowledge, tools, and equipment required to do the job properly and safely. It informs these Technicians of conditions that may occur on some vehicles, or provides information that could assist in proper vehicle service. The procedures should not be performed by 'do-it-yourselfers'. If you are not a Retailer, do not assume that a condition described affects your vehicle. Contact an authorized Land Rover service facility to determine whether this bulletin applies to a specific vehicle.

SECTION: 501-12

Update Prior to Sale: Overhead Console Sunglasses Holder

AFFECTED VEHICLE RANGE:

Range Rover Evoque (LV)

Model Year: 2015

VIN: FH [REDACTED] -FH [REDACTED]

MARKETS:

NAS

CONDITION SUMMARY:

Situation: A potential issue has been identified on a limited number of 2015 model year Range Rover Evoque (L538) vehicles where the overhead console sunglasses holder does not remain closed and/or sunglasses may rattle when stowed.

Action: Retailers are required to **HOLD** only affected vehicles that are within your control and refrain from releasing the vehicles for new or used vehicle sale pending completion of the rework action detailed in this Technical Bulletin. Unsold vehicles should have this performed as part of the Pre-Delivery Inspection (PDI) process but **must** have it completed prior to vehicle handover to the customer. Affected vehicles already in the hands of customers should be updated at the next available opportunity.

PARTS:



NOTE: * when ordering parts, order only the expected percentage demand of parts identified

DESCRIPTION	PART No. / SUNDRY CODE	QTY. / VALUE	EXPECTED % of VEHICLES REQUIRING PARTS*
Sunglasses holder - Cirrus	LR068338	1	53%
Sunglasses holder - Ivory	LR068339	1	30%
Sunglasses holder - Ebony	LR068340	1	17%

SPECIAL TOOLS:

Refer to Workshop Manual / Service Instruction for any required tools

WARRANTY:



NOTE: Check DDW to ensure that a vehicle is affected by this program prior to undertaking any rework action. Repair procedures are under constant review, and therefore times / prices are subject to change; those

quoted here must be taken as guidance only. Refer to TOPIx to obtain the latest repair time. At the time of confirming a booking for vehicle repair, ensure that all outstanding Service Actions are identified to ensure the correct parts are available and adequate workshop time is allocated for repairs to be completed at one visit.

Warranty claims must be submitted quoting Program Code '**Q417**' together with the relevant Option Code from the table. The SRO and part information listed have been included for information only. The Option Code(s) that allows for the drive in / drive out allowance may only be claimed if the vehicle is brought into the workshop for this action alone to be undertaken.

This program is valid for a limited time only. Warranty claims with a repair date prior to the **10 April 2015** closure date must be submitted for payment within 30 calendar days of completion of the repair.

PROGRAM CODE	OPTION CODE	DESCRIPTION	SRO	TIME (HOURS)	PARTS / SUNDRY CODE	QTY. / VALUE
Q417	B	Sunglasses holder - Renew (Ebony)	76.25.18	0.20	LR068340	1
Q417	C	Sunglasses holder - Renew (Ebony) Drive in/drive out	76.25.18 02.02.02	0.20 0.20	LR068340 -	1 -
Q417	D	Sunglasses holder - Renew (Ivory)	76.25.18	0.20	LR068339	1
Q417	E	Sunglasses holder - Renew (Ivory) Drive in/drive out	76.25.18 02.02.02	0.20 0.20	LR068339 -	1 -
Q417	F	Sunglasses holder - Renew (Cirrus)	76.25.18	0.20	LR068338	1
Q417	G	Sunglasses holder - Renew (Cirrus) Drive in/drive out	76.25.18 02.02.02	0.20 0.20	LR068338 -	1 -

Normal Warranty policies and procedures apply

SERVICE INSTRUCTION:

1. Remove the front overhead console (see TOPIx Workshop Manual, section 501-12).

2. Hold the rear cover and push the sunglasses holder cover in the direction shown.
 - Lift up to disengage the two rear plastic clips.
 - Push the outboard clip tower in direction shown, allowing the sunglasses holder cover to be lifted upwards away from the metal clip.
 - Repeat for the other side.
 - Remove the sunglasses holder cover from the front overhead console.

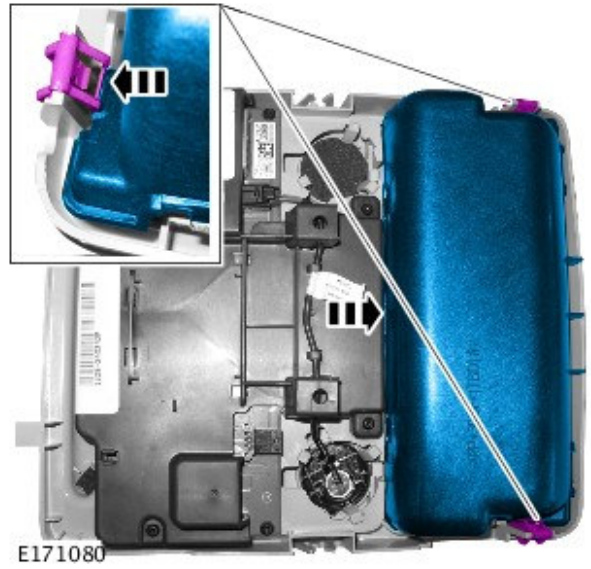

3.  **NOTE: Make sure the foam edge is aligned with rear edge of the sunglasses holder cover.**

Install the foam pad to the sunglasses holder cover.

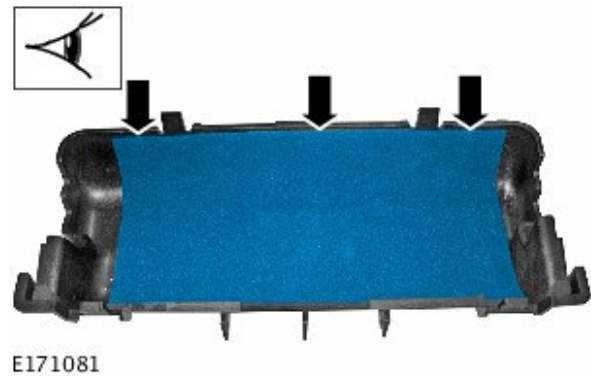

4. Install the second foam pad; to be fitted to the new sunglasses holder with the foam covering the majority of the holder.



5. Remove and discard the screw on the side of the sunglasses holder.

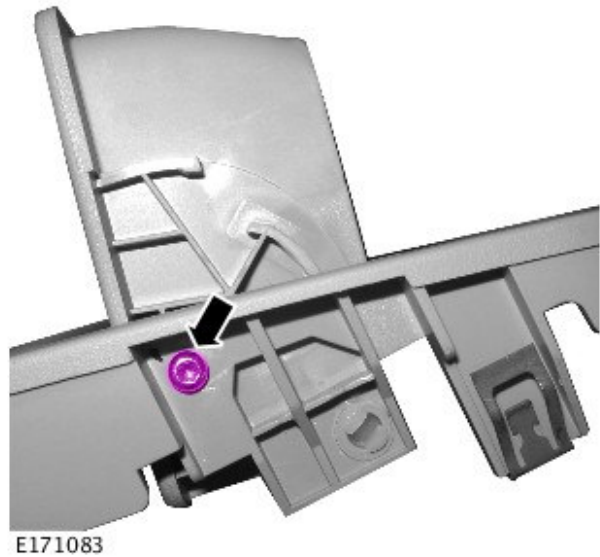

6. Remove and discard the sunglasses holder:

- Remove the pin near to the damper;
- Remove the pin on the other side of sunglasses holder door;
- Discard the sunglasses holder.

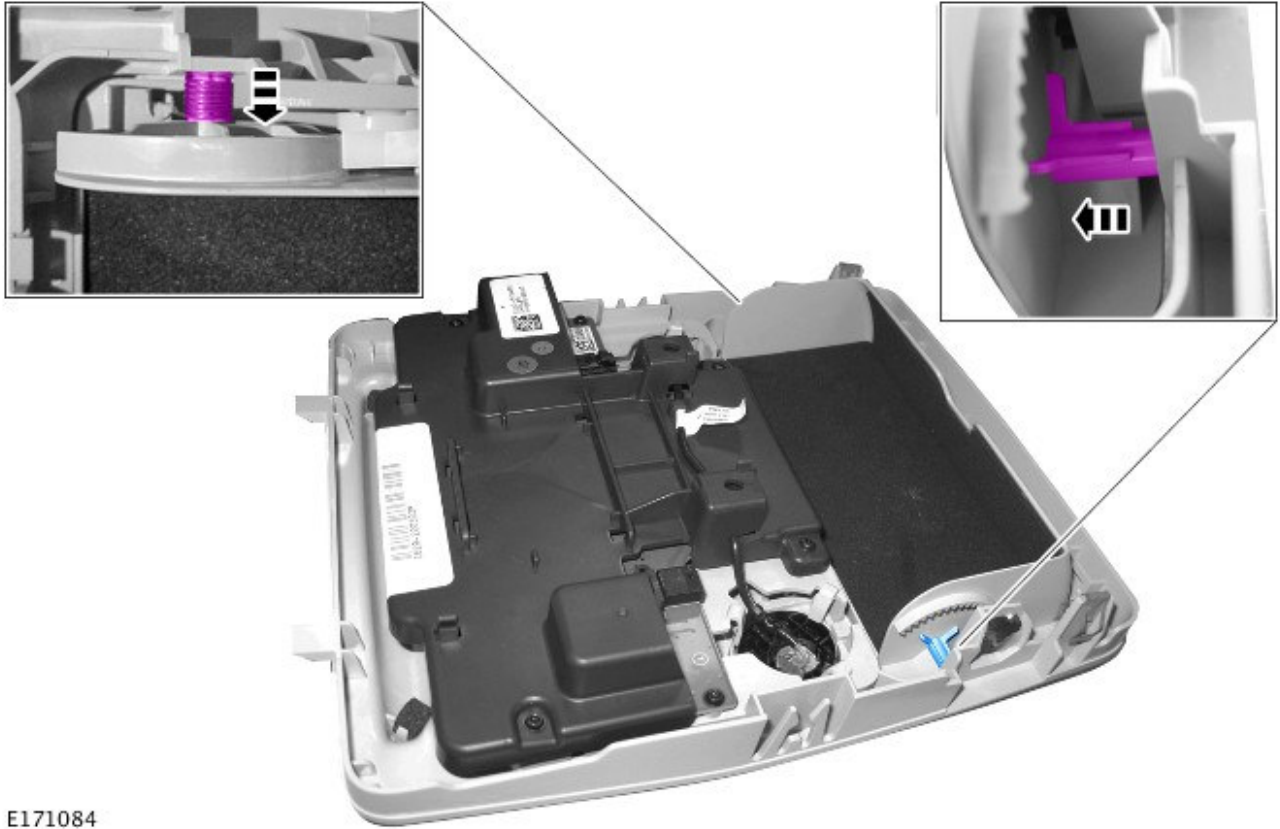

E171084

- 7.  **NOTE: Nyogel 774L (from the Squeaks & Rattles Kit; refer to Technical Bulletin LTB00389NAS).**

Using Nyogel 774L or equivalent, apply into the hinge pin holes.



E171086

- 8.  **NOTE: Make sure the spring is positioned**

correctly.

Install the new sunglasses holder.

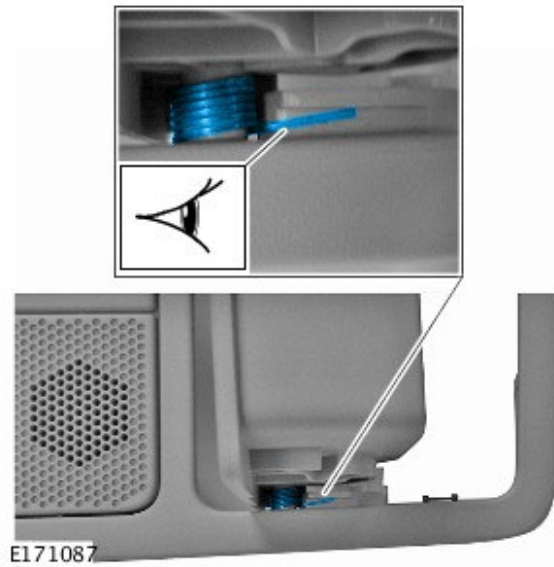

9. Open/close the sunglasses holder three times to check correct functionality.

10. Install the sunglasses holder cover.

11. Install the front overhead console (see TOPIx Workshop Manual, section 501-12).