



TECH TIMES

The Professional Publication for Kia Dealership Technicians & Service Staff

2014

Volume 17, Issue 3

Inside this Issue:

Page

- | | |
|---|--|
| <p>1 Kia Diagnostic System (KDS) Introduction</p> <p>3 New Kia University Courses and Tests</p> <p>3 K900 and Cadenza Elite Plus Certification</p> <p>4 DTC P0456 and Charcoal Canister Leaks</p> <p>4 Continuously Variable Valve Timing Overview</p> <p>5 Crossword Puzzle</p> <p>6 Diagnosing Sirius Traffic Issues</p> <p>7 GDI Injector Spray Tip Deposits</p> | <p>8 Optima Hybrid Cruise Control Inoperative</p> <p>8 Rough Idle After Cold Start On 3.3L GDI Engine</p> <p>9 Making Sense of Switch and Output Control Circuits</p> <p>10 GDS - Graphing Data Using Zoom Feature</p> <p>11 DTC P1B70/P1B74/ P1B96 - High Voltage Battery Sensor Circuit Fault</p> <p>11 Crossword Puzzle Solutions</p> |
|---|--|

Kia Diagnostic System (KDS) Introduction

Kia Motors America has been working on the next generation of the GDS Diagnostic tool known as "Kia Diagnostic System (KDS)". Below are a few key features; as more details will follow in future issues of TechTimes.



KDS Features	
Tablet	VCI-II
Portability Improvement based on mobile technology	Compact vehicle communication interface
Mobile Platform with Android OS	Supports Flexray protocol
User Interface Improvement	Vehicle communication & flight record
Diagnostic Functions Enhancement	Wireless communication with Tablet (Bluetooth or Wi-Fi Direct)
Shorten DTC searching time	Memory size (8GB)
Real-Time service information	

KDS Connectivity

Dealerships are required to meet the following Wi-Fi minimum requirements listed below, by October 1, 2014.

- Connectivity in all service bays and service drive
- Internet connection 256k or higher
- 802.11 a/b/g/n/ac wireless networks

Note: 802.11 ac recommended

Tech Line FAQs

Model/Year	Question	Answer
2011, 2012 and 2014 VQ Sedona	The R/F window switch does not illuminate?	This is normal operation these vehicles are not equipped with an illuminating R/F door window switch.
All Model w/ Sirius Radio	Satellite radio inoperative and no signal is displayed?	Check for a five volt reference signal to the antenna base for the satellite circuit. If five volts is present, replace the antenna base to resolve the concern.
All Models	If a technician runs into a problem where they cannot log into the Techline web portal who do they contact?	Please contact the DCS helpdesk at (800) 327-2707 and report the concern.
All Models	How do I access the transmission overhaul manuals?	In KGIS without selecting a model, scroll down and select the correct transmission application from the drop down list provided.
All Models	I would like to add a flight recording file to my Techline case. How do I accomplish this?	Flight recorder files cannot be attached directly to existing TechLine cases because they cannot be opened in the correct format. If you need to send in a flight recorder file for review, please email it to the Techline agent that is assisting you with the case. The agent will provide you with the correct email address.

Latest Technical Service Bulletins, Service Actions and Campaigns

- ENG 114r1** Aftermarket Oil Filters and Oil Viscosity
- GEN 069** UVO eServices (AVN 4.0) - Technology Highlights
- SC 107** 19" Non-Chrome Wheel Assembly Replacement
- CLI 024** Testing A/C Compressor Function Using GDS
- CHA 044** MDPS Flexible Coupling Replacement
- SC 105** ECM Logic Upgrade - Sorento (XMa) 3.5L MPI
- SA 166** Service Action - Paint Peeling Off Door Panels
- BOD 104** Driver's Side Seat Cushion Cover Detaching

CAUTION

VEHICLE SERVICING PERFORMED BY UNTRAINED PERSONS COULD RESULT IN DAMAGE TO THE VEHICLE.

WARNING

- Vehicle servicing performed by untrained persons could result in injury to those persons or to others.
- Always take proper and necessary safety precautions when performing any type of service on a vehicle.
- The Kia technician newsletter (Tech Times) is intended for use by professional Kia automotive technicians only. It is written to inform technicians of conditions that may occur on some vehicles. Trained Kia technicians have the equipment, tools, safety instructions, publications and expertise to help perform the job correctly.

* NOTICE

The topics covered in this newsletter are designed to assist you with the diagnosis and repair of specific vehicle conditions. Just because a condition is described in this newsletter, do not assume that it applies to your vehicle, or that your vehicle will have that condition. In all cases, the procedures in the applicable Service Manual and/or Electrical Troubleshooting Manual or on KGIS should be performed first.

Copyright © 2014 Kia Motors America, Inc. All rights reserved. No part of this publication may be reproduced, stored electronically, or transmitted in any form or by any means without prior written approval from Kia Motors America, Inc. ("KMA"). KMA reserves the right to make any changes in the descriptions, specifications, or procedures at any time.

© Kia Motors America, Inc. ■



Published by Kia Motors America, Inc. and produced by Kia University. All rights reserved.

Director, Kia University
David Wobst

Tech Times Editor
Lewis Thompson

Production Coordinator
Carlos Sicairos

Tech Times Contributors

Barry Nelson
Brian Lockhart
Joe Alt
Tony Cartagena
Shari Brady
Steve Strain
Ray Taylor
Neal Moen
Carlos Sicairos
Pete Ferry

Technical Editors
Neem Van der Reest
Lewis Thompson

Engineering Support & Technical Writer

Neem Van der Reest

Technical Writer
Mario Garcia

K900 and Cadenza Elite Plus Certification

Pursuing ongoing Technical Training and Elite Certification will enable you to be among the uniquely qualified group of service team members who have been prepared to help move the Kia brand into the premium marketplace.

Current standing Elite Plus (ASE) Certified technicians have the opportunity to achieve **K900 and Cadenza Elite Plus Certification** with successful completion of the following courses:

- 2014 Cadenza Technical Highlights web-course
- 2014 Cadenza Diagnosis course conducted at a Kia Motors Technical Training Center
- 2015 K900 Pre-Delivery Inspection web-course
- 2015 K900 System Diagnosis course conducted at a Kia Motors Technical Training Center

In honor of this achievement, you will earn a set of K900 & Cadenza uniform patches to display on your uniforms.



Congratulations! As of June 12th 2014, the following Elite Technicians have earned K900/Cadenza **Master** Elite Plus Certification:

CENTRAL REGION			
Technician	Dealer	City	State
Gregory Dubs	Gerald Kia of Naperville	Naperville	IL
Bradley Gostlin	Bill Doraty Kia	Medina	OH
Stephen Holley	Kia Store East	Louisville	KY
Billy Beaver	Jim Butler Kia	Chesterfield	MO
Joey Smith	Napletons Mid Rivers Kia	St. Peters	MO
Mike Steitz	Napletons Mid Rivers Kia	St. Peters	MO

EASTERN REGION			
Technician	Dealer	City	State
Paul Firth	Sansone Kia	Avenel	NJ
Lawrence Phillips	First Team Kia	Chesapeake	VA
John Passamonte	Dorschel Kia	Rochester	NY

SOUTHERN REGION			
Technician	Dealer	City	State
Ray Pitner	Cobb County Kia	Kennesaw	GA
Jeffrey Jacobs	West Palm Beach Kia	West Palm Beach	FL
Mike Moretti	Kia of Vero Beach	Vero Beach	FL
Calvin Riggins Jr	Kia Country of Savannah	Savannah	GA
Maurice Grant	DeMontrond Kia	Houston	TX
Scott Dutzel	Gay Family Kia	Dickinson	TX
Jeremy Gibson	Pete's Car Smart Kia	Amarillo	TX
Babak Nadimi	Central Kia of Lewisville	Carrollton	TX
David Wilson	Galeana Kia	Columbia	SC
Seth Heffner	Paramount Kia	Hickory	NC
Humberto Garcia	Moritz Kia	Forth Worth	TX

WESTERN REGION			
Technician	Dealer	City	State
Rod Adams	Citrus Kia	Ontario	CA
Kenny Do	Covina Valley Kia	Covina	CA
Robert Ouellet	Kia of Irvine	Irvine	CA
Edwin Torossian	Car Pros Kia Glendale	Glendale	CA
Mike Speed	North County Kia	Escondido	CA
Don Way	Ball Kia	National City	CA
Aaron Selby	Jim Marsh Kia	Las Vegas	NV
Michael Clark	Dublin Kia	Dublin	CA
Vernon Vanover	Camelback Kia	Phoenix	AZ
Robert Laursen	Larry H. Miller Kia Lakewood	Lakewood	CO

DTC P0456 and Charcoal Canister Leaks

When addressing a concern related to a DTC P0456 (Evaporative Emissions System – Small Leak Detected) on 2011-2014 Optimas, and inspection of the vapor lines, connections and fuel cap reveal no abnormalities, closely inspect the mounting holes of the charcoal canister for visible cracks (refer to the images to the right). If cracking is found, replace the charcoal canister per the applicable procedure on KGIS. If no cracking is found, please proceed with normal evaporative system diagnostics.

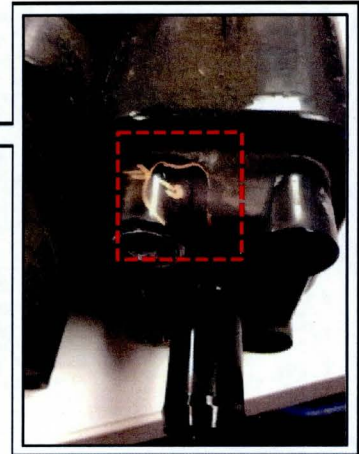

Please refer to Pitstop PS 322

Continuously Variable Valve Timing Overview

The Continuously Variable Valve Timing (CVVT) system allows the PCM to change the rotational position of the camshaft relative to the position of the crankshaft. Depending on the engine and vehicle, the intake camshaft can be rotated to operate the intake valves earlier, or the exhaust camshaft can be rotated to operate the exhaust valves later. The movement is made by a phaser at the end of a camshaft and is operated by oil pressure, controlled by a solenoid called Oil Control Valve (OCV). The PCM grounds the OCV with Pulse Width Modulation (PWM). Oil pressure rotates the camshaft forward or backward relative to the camshaft sprocket.

Intake camshafts are normally* in a retarded position. The CVVT system advances the camshaft. Retard means the camshaft is operating later relative to crankshaft position. The normal position is held as controlled by PCM and

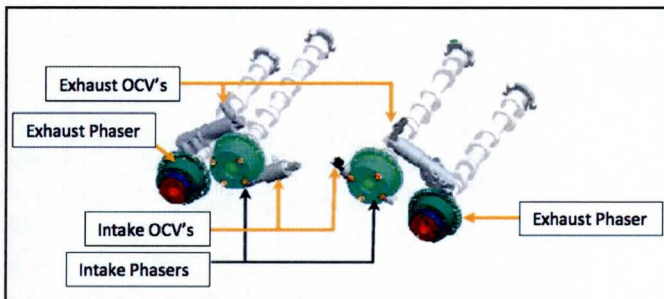

regulated by OCV with a spring loaded lock pin; oil pressure releases the lock pin.

Exhaust camshafts are normally* in an advanced position. The CVVT system retards the camshaft. Advance means the camshaft is operating earlier relative to crankshaft position. The normal position is held with a spring, visible in the center of the housing.

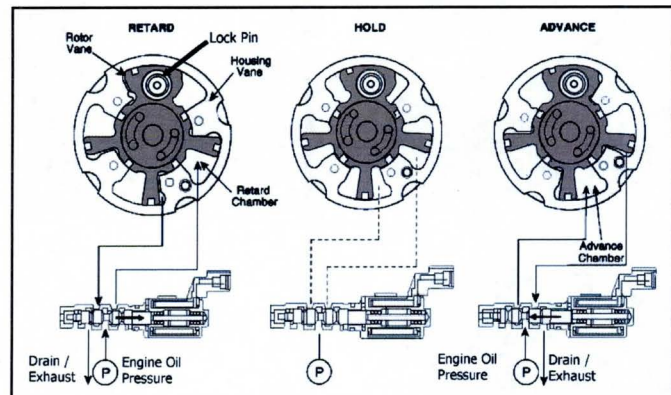

*Normal position (phasers at rest or "HOLD"): Whenever the PCM is not operating the OCV in such a way as to move the camshaft from its normal advanced or retarded position. Normal position would be at idle, or when the vehicle is shut off, or when the PCM decides adjustment would not be appropriate or possible in those cases (typically the PCM will set DTCs).

Depending on the vehicle, a DTC can set if the Cam/Crank relationship is not correct, or, if the camshaft is not advancing or retarding fast enough. Basically, the PCM perceives that the camshaft and crankshaft are not in their "assigned" positions.

No camshaft phaser movement occurs at idle. At idle the camshaft phasers are in their 'normal/at rest' position. It's only when the vehicle is accelerated and or driven that the camshafts move. Therefore a CVVT DTC sets because the PCM detects that either the camshaft/s are advanced at idle, or the camshaft/s don't move when the vehicle is accelerated. Also, a mis-timed belt or chain, or damaged or

Continued next page

Continuously Variable Valve Timing Overview (Continued)

mis-positioned CKP or CMP sensors will trigger timing to set, even if all of the CVVT components can function normally.

Oil concerns can lead to a DTC or possible component failure. Improper oil viscosity can cause lack of lubrication and improper CVVT operation and DTCs. Likewise oil that is of poor quality or has been left in too long can also lead to buildups, wear or failure. Poor quality oil filters can either starve the CVVT (like any other lubricated part) or a poor quality oil filter may allow particles to circulate, allowing a buildup of debris causing failure or DTCs.



Crossword Puzzle

Test your knowledge of the articles in this issue of TechTimes by completing this crossword puzzle. The solution to this month's puzzle can be found on page 11.

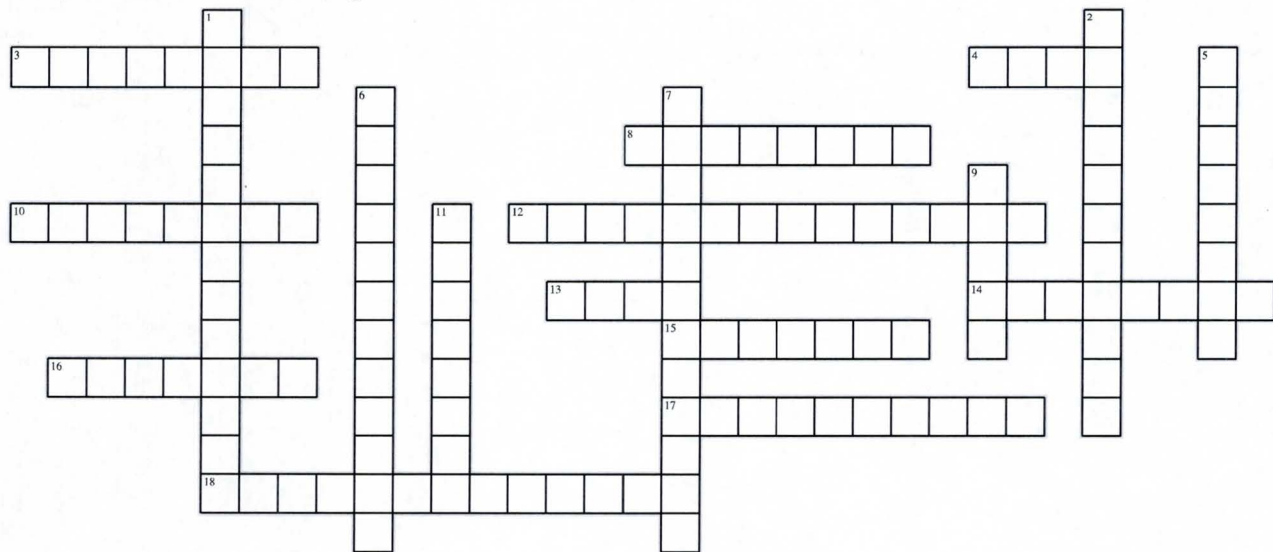

Across

3. One of the first inspections when the satellite radio is not working is to check for _____ reference at the antenna base. (Two Words)
4. No camshaft movement occurs at _____ when the CVVT system is working properly.
8. The internals of the injector are designed to _____ the formation of deposits.
10. One of the main features of the new KDS is _____ - _____ Service Information. (Two Words)
12. Duplicating the cell voltage difference may not be possible when viewing in Ready Mode and a _____ may need to be used to properly diagnose. (Two Words)
13. The transistor can operate as a switch by controlling the _____ of the transistor.
14. Exhaust camshafts are normally in a _____ position.
15. The most common type transistor is the _____ - _____ control typically used to control things such as fuel injectors, ignition coils and solenoids. (Two Words)
16. When addressing a high Voltage Battery Sensor Circuit Fault code, inspect for one or more HEV battery cells showing _____, or more, lower than the rest of the cells. (Two Words)

17. The CVVT system allows the PCM to change the position of the camshaft relative to the position of the _____.

18. When navigation unit is replaced the _____ must be deactivated on the old unit and activated on the new navigation unit. (Two Words)

Down

1. When performing an Evaporative system inspection on a QF/TF Optima with a P0456 code, closely inspect the _____ of the charcoal canister for visible cracks. (Two Words)
2. If you have a Hybrid Optima with Cruise Control inoperative, you must perform a _____ sensor calibration. (Two Words)
5. Intake camshafts are normally in a _____ position.
6. One of the first steps when diagnosing a Sirius Traffic not displaying concern, is to confirm that all traffic features are set to "ON" in the _____ menu. (Two Words)
7. GDI injectors operate at high pressure and deliver fuel through injector spray orifices near the center of the injector tip, at a _____ . (Two Words)
9. A simple transistor circuit can replace a _____ to control output devices.
11. Request Sirius® to refresh the signal and ensure that the vehicle is in an _____ or being driven when this occurs. (Two Words)

Diagnosing Sirius® Traffic Issues

This article provides diagnostic information in regards to specific Sirius® Traffic customer complaints, as detailed below:

- Sirius® Traffic Button on touch screen is grayed out (not highlighted)
- No traffic flow lines appear on map and traffic alert pop-ups are not displayed.
- Sirius® Traffic does not display when vehicle is started in an area with poor Sirius reception.



Sirius® traffic is not being displayed

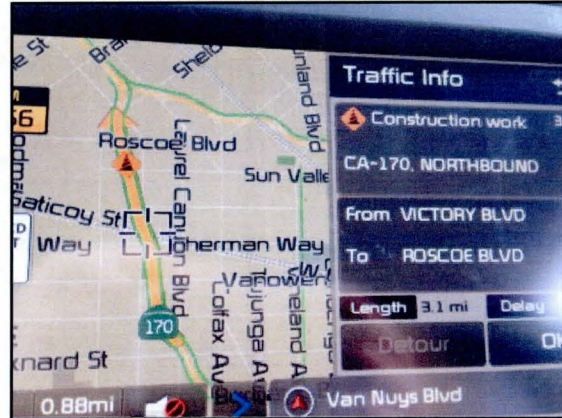

Sirius® Traffic is displayed

Diagnostic Procedure:

- Confirm the customer's issue. **Note: It may sometimes take a few minutes for Sirius® Traffic to become activated (Sirius icon turns white or highlighted) when a vehicle is first started.**
- Confirm that all traffic features are set to "ON" in the **Traffic Setup** menu.

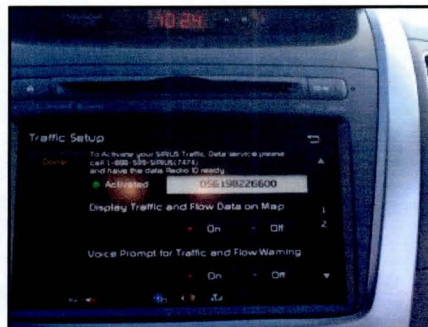
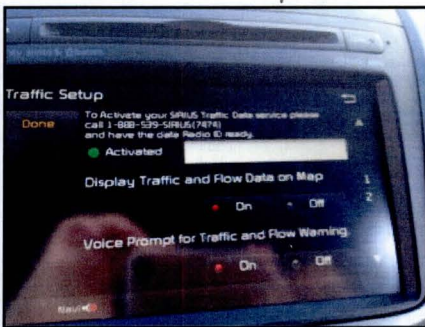

- Try resetting the head unit by pressing the reset button, if available, and/or remove the SD Card and reinstall. Confirm the traffic features are set to "ON" as they may default to "OFF", on some platforms, after resetting.
- Call Sirius at the OEM Dealer Support number (888) 465-8528 and confirm Sirius® Traffic is activated by providing the ESN number or numbers (found on Sirius® Channel 0 and traffic is sometimes found in the traffic setup screen). **Note: Some vehicle head units have two ESN numbers, one for audio and one for data traffic, and others have one ESN number for both audio and traffic.**
- Request Sirius® to refresh the signal and ensure that the vehicle is in an open area or being driven when this occurs.
- A traffic issue may exist on some 2014 Sorento (XMa), Forte (YD), Optima (QF/TF), and Sportage (SL) vehicles which contain the original software revision levels shown in the table on next page. This condition occurs, more often, in large metropolitan areas (i.e. Los Angeles, Chicago, etc.) as original software revision levels did not contain the required Sirius® information for these locations. These issues can be resolved by replacing the navigation unit with one ordered from the PDC. Upon receipt, ensure the replacement head unit contains the updated software revision level by referring to the table on the next page.

Continued next page

Diagnosing Sirius Traffic Issues (Continued)

Model	Original Software Revision Level	Updated Software Revision Level*
2014 Sorento (XM)	SOP.018	SOP.018P
2014 Sorento (XM)	SOP.021~	SOP.036P (or higher)
2014 Forte (YD)	SOP.015	SOP.015P
2014 Forte (YD)	SOP.019	SOP.034P (or higher)
2014 Optima (QF)	Multiple Versions	SOP.008N (or higher)
2014 Sportage (SL)	Multiple Versions	SOP.008P (or higher)

*This software was applied to production vehicles in early 2014

NOTE: For 2014 Cadenza (VG) refer to TSB Electrical 062 for Software Update for Sirius® Traffic Issues.

Steps to take after replacement of navigation unit:

If a Navigation unit replacement is performed, ensure that the Sirius® account is turned off on the customer's original unit and that the subscription is activated on the new navigation unit to ensure that the customer continues to receive their service with no interruption. **Note: Remember to install the customer's original SD card in the replacement unit and to confirm the traffic feature is operational.**

Please Refer to Pitstop PS 318

GDI Injector Spray Tip Deposits

A design feature of vehicles equipped with a Gasoline Direct Injection (GDI) system is the placement of each fuel injector directly into the engine cylinder head assembly. Therefore, it is completely normal for the combustion process to create deposits on the injector spray tip surfaces. Although spray tip deposits may appear to be heavy enough to affect injector performance, there is actually no change in the fuel delivery or spray pattern. GDI injectors operate at high pressure and deliver fuel through small spray orifices near the center of the injector tip, at a high velocity. As a result, combustion deposits that form near the injector spray orifices are washed away as fuel is delivered. In addition, the injector ball and seat are engineered to reduce any potential effects of carbon coking.

NOTE: Ultra-sonic or mechanical cleaning of GDI fuel injectors should never be done in an attempt to improve vehicle drivability or injector performance. Attempting to remove spray tip deposits through mechanical means, such as wire brush cleaning or scraping, will damage the spray orifices and degrade injector performance.



The internals of the Injector are designed to minimize the formation of deposits



New injector showing location of Spray Orifices



Normal injector appearance while in service

Please refer to Pitstop PS 315

Optima Hybrid Cruise Control Inoperative

If you are diagnosing a vehicle where the customer states the cruise control is inoperative and cruise control light comes ON but will not set, go to each module individually and verify that there are no codes active or stored in any of the systems. If all the systems check out ok, perform a Pedal Travel sensor (PTS) calibration found on the AHB module software management tab under Data Treatment. Once the test has successfully passed, test drive the vehicle, you should now have proper operation of the cruise control system.

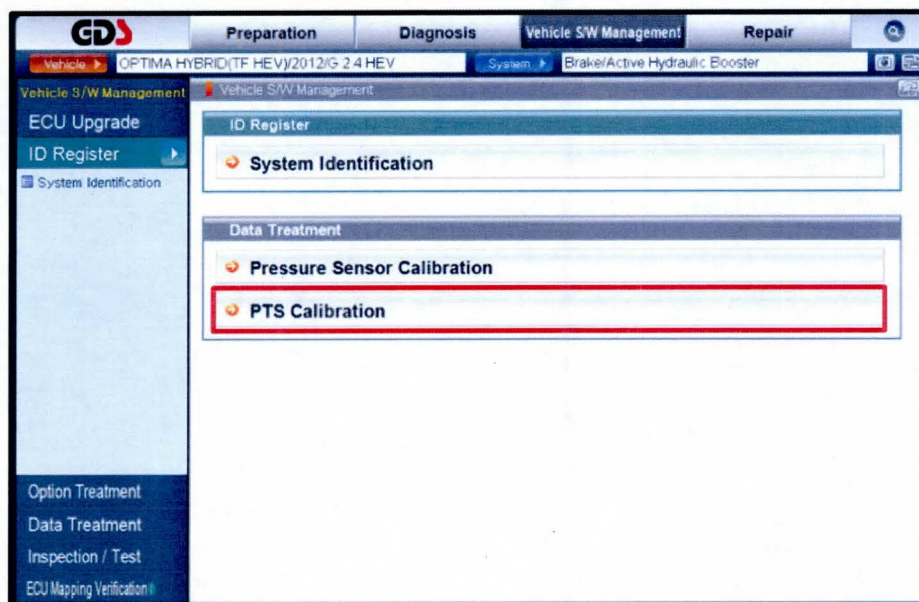

Rough Idle After Cold Start On 3.3L GDI Engine

When addressing a customer complaint of rough idle on a Sorento or Cadenza, which occurs only on the first start of the day and lasts for, approximately, 30-45 seconds, check for the possibility of poor injector performance on a particular cylinder. This concern may feel like a misfire, however, it is not an emissions or catalyst damaging misfire and it does not typically trigger any DTC(s). To correct this condition, use GDS to monitor for Current Misfire Counts on all 6 cylinders during the first cold start in the morning, to help determine which cylinder is responsible for the rough idle condition. Replace only the injector for the indicated cylinder. To verify the repair, recheck again after an overnight cold soak to make sure the rough idle condition is no longer present.

The example below shows a rough idle condition on cold start due to the Injector in Cylinder #5.

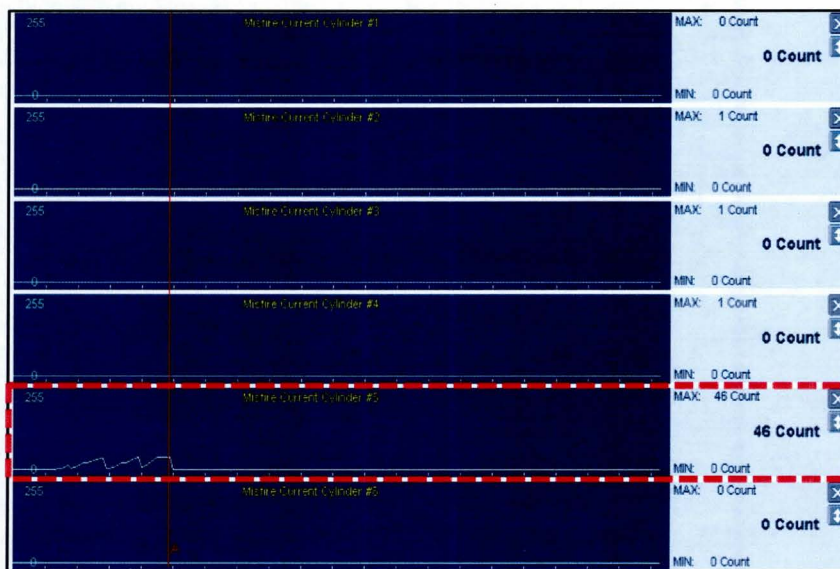

Please refer to Pitstop PS 320

Making Sense of Switch and Output Control Circuits

In the previous Issue, we covered two types of relay circuits used in Kia vehicles:

- High-side control — B+ supplied to the control side of the relay.
- Low-side control — Ground applied to the control side of the relay.

In this issue, we will discuss two types of transistor circuits used in Kia vehicles:

- High-side control — B+ supplied to the component.
- Low-side control — Ground applied to the component.

The transistor can operate as a switch by controlling the BASE of the transistor

In the low side driver circuit, applying voltage to the BASE turns it ON.

In the high side driver circuit, grounding the BASE turns it ON.

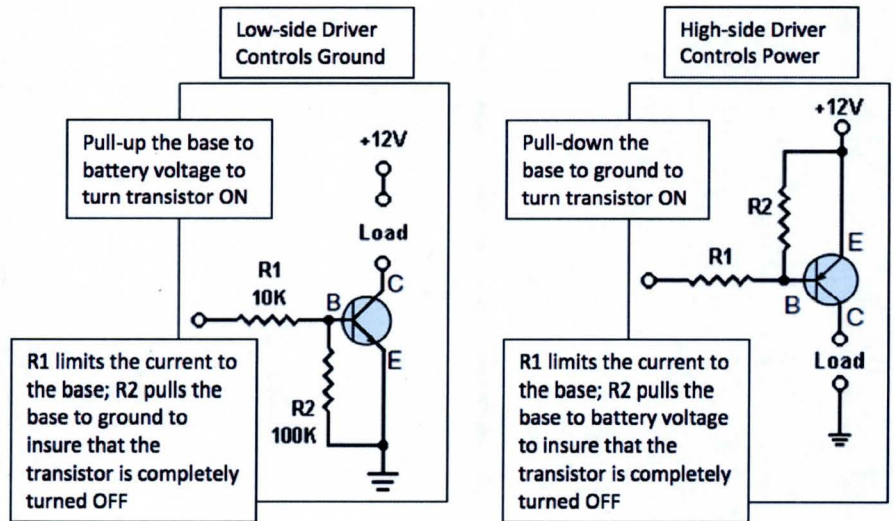

A simple transistor circuit can replace a relay to control output devices.

The most common type is the low-side control typically used to control things such as fuel injectors, ignition coils, and solenoids.

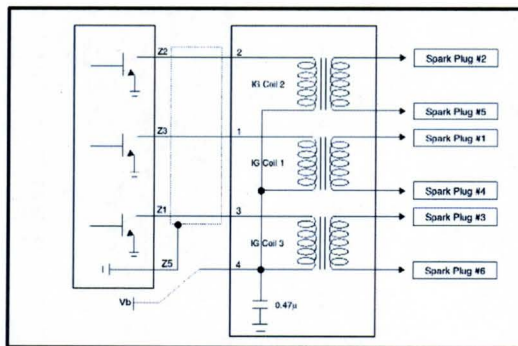

Ignition coils

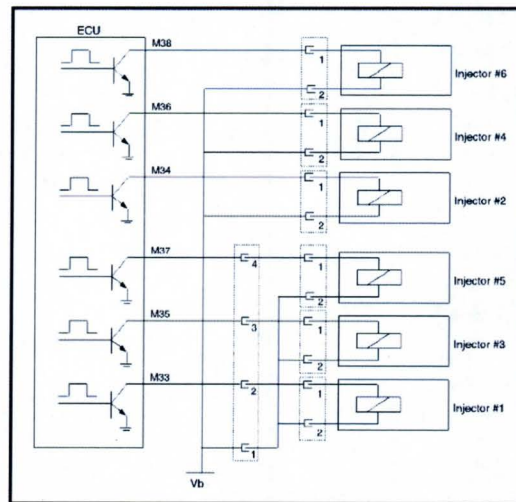

Fuel Injectors

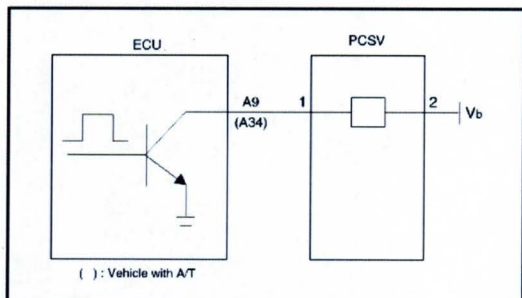

Solenoid

Continued next page

Making Sense of Switch and Output Control Circuits (Continued)

Early systems used high-side control. For example, early transmission solenoids. The three Automatic Transaxle Solenoid Valves are hardwired to ground and the control side provides voltage to each solenoid to turn it on.

Later systems use low side control. For example, later transmission solenoids. The the six Automatic Transaxle Solenoid Valves are supplied power from the ATM Control Relay and the control side provides ground to each solenoid to turn it on.

In our next issue we will discuss ways to test output transistor circuits with a DVOM, GDS Current Data, GDS Actuation Tests, and GDS w/VMI Oscilloscope.

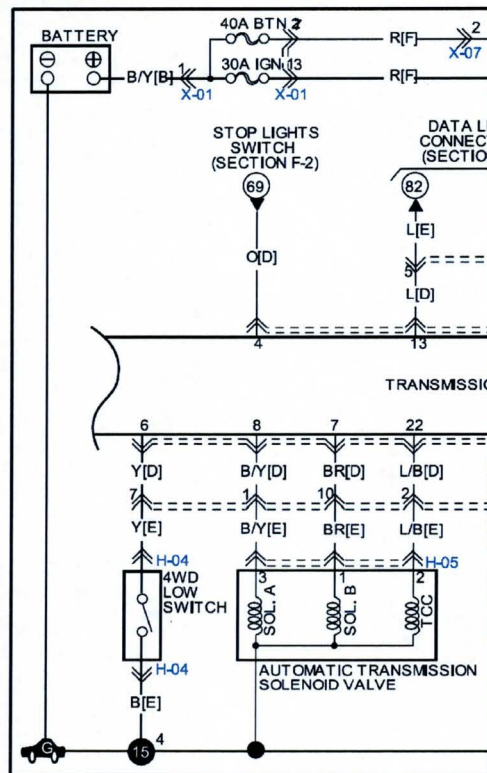

High-side control

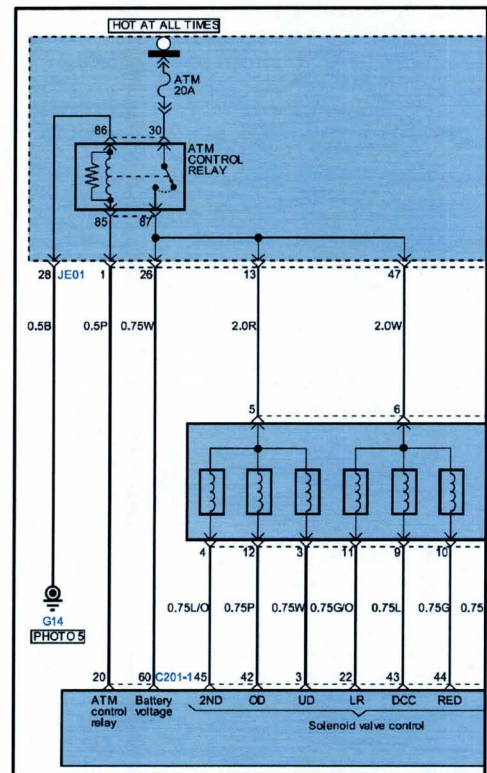

Low-side Control

GDS - Graphing Data Using Zoom Feature

To get a better view of the signal waveform when diagnosing a possible problem with a sensor or circuit, one useful feature of the GDS graphing data is the Zoom (Up/Down) button, located on the right side below the [X] button. This button allows the user to zoom in and get a better view of the sensor glitches/erratic signals and helps the user identify intermittent sensor issues.

Example: Wheel Speed Sensor data using the Zoom feature on GDS.

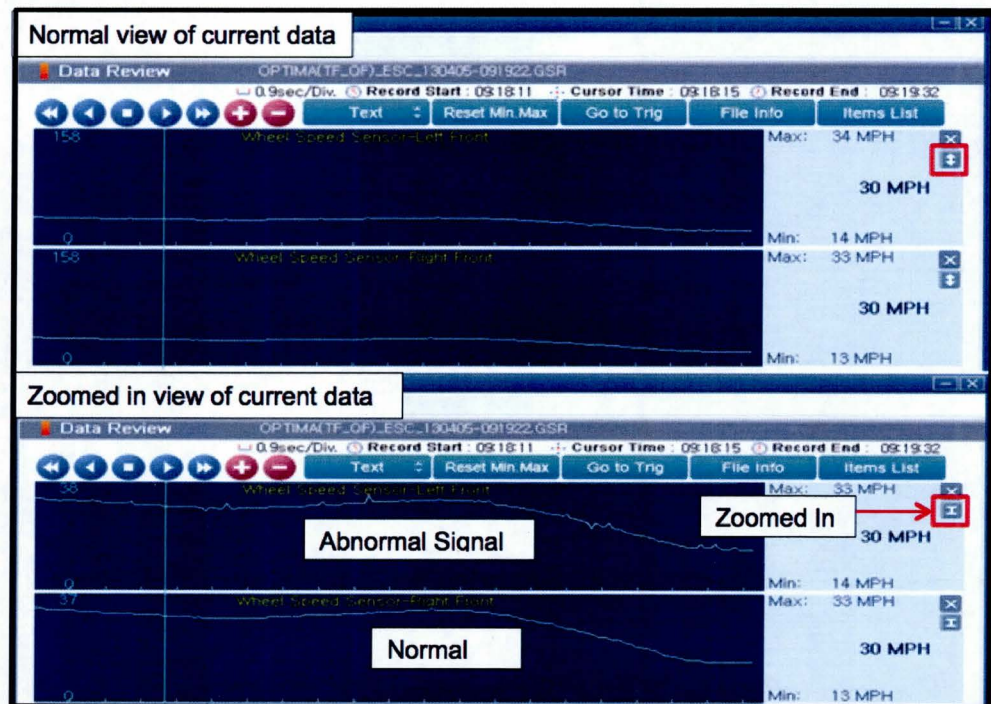

DTC P1B70/P1B74/ P1B96 - High Voltage Battery Sensor Circuit Fault

When addressing a customer complaint related to a battery warning lamp illuminated in the dash and drivability issues on Optima Hybrid, access GDS to check for any active DTC(s). Also, review the **BMS > Current Data** to inspect for one or more HEV battery cells showing one (1) volt, or more, lower than the than rest of the cells (see below). Duplicating this condition may not be possible when viewing in Ready Mode. If so, test drive the vehicle with a flight recorder to capture the event in city driving conditions. Send all supporting information to Techline for documentation of condition and further diagnosis.

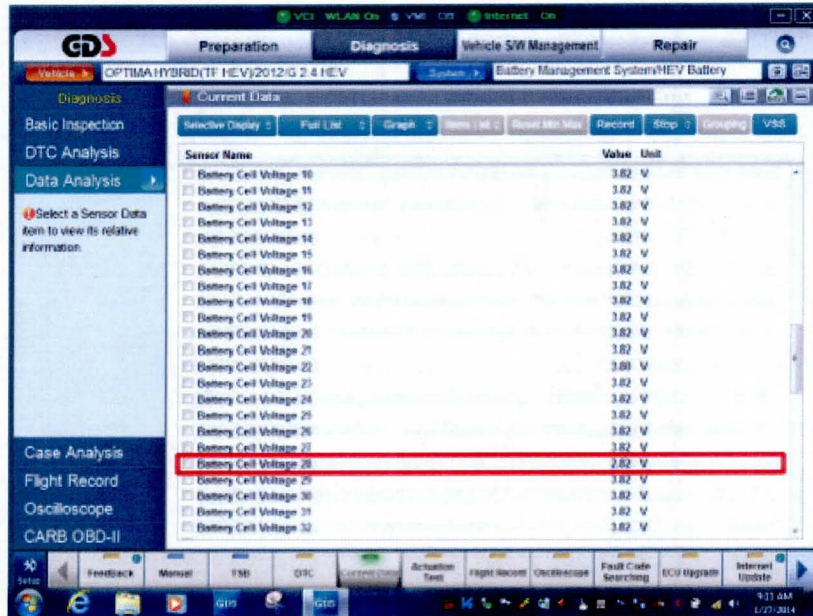

Please refer to Pitstop PS 292

Crossword Puzzle Solution

We hope you gave this issue's crossword puzzle on page 5 a try. In case you need a little help, here are the answers to the puzzle clues.

