

TECHNICAL BULLETIN  
LTB00648NAS1  
17 NOV 2014



© Jaguar Land Rover North America, LLC

NOTE: The information in Technical Bulletins is intended for use by trained, professional Technicians with the knowledge, tools, and equipment required to do the job properly and safely. It informs these Technicians of conditions that may occur on some vehicles, or provides information that could assist in proper vehicle service. The procedures should not be performed by 'do-it-yourselfers'. If you are not a Retailer, do not assume that a condition described affects your vehicle. Contact an authorized Land Rover service facility to determine whether this bulletin applies to a specific vehicle.

**SECTION: 418-02**

Harness Repair Terminal Block C44-R2

**AFFECTED VEHICLE RANGE:**

**Range Rover (LG)**

**Model Year:** 2013

**VIN:** DA108006-DA118089

**MARKETS:**

NAS

**CONDITION SUMMARY:**

**Situation:** The following symptoms may occur:

- engine will not start;
- Touch Screen inoperative;
- windows inoperative;
- seats in inch mode; and/or
- climate control panel not illuminated or non-responsive.

**Cause:** These may be caused by terminal block C44-R2 pins 10, 17, 18, and/or 21 having poor continuity.

**Action:** If during diagnosis of the issue terminal block C44-R2 is suspected to have poor continuity, follow the service instruction outlined below. If during diagnosis of the issue terminal block C44-R2 is not suspected to have poor continuity, continue with diagnosis with reference to Symptom Driven Diagnostics and TOPIX

**PARTS:**



**NOTE:** Each of the part number is supplied in packs containing ten or more pieces sufficient for several vehicles.



**NOTE:** All four terminals may not require replacing; only use the quantity of terminals required for the repair.

418107	Splice joint connector	Quantity: 4
41841145	Repair terminal	Quantity: 4
418112	Identification sleeve	Quantity: 4

**TOOLS:**

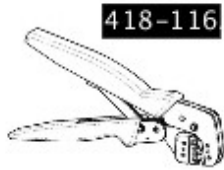

E164242

Crimping pliers  
418-116A

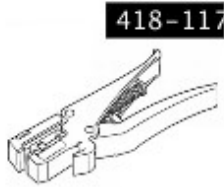

E164243

Insulation stripper  
418-117

**WARRANTY:**

**NOTE: Repair procedures are under constant review, and therefore times are subject to change; those quoted here must be taken as guidance only. Always refer to TOPIx to obtain the latest repair time.**

**NOTE: DDW requires the use of causal part numbers. Labor only claims must show the causal part number with a quantity of zero.**

DESCRIPTION	SRO	TIME (HOURS)	CONDITION CODE	CAUSAL PART
Harness - Tailgate - Repair -	<b>86.71.89.51</b>	1.9	42	LR046858

**NOTE: Normal Warranty procedures apply.**

**SERVICE INSTRUCTION:**

**NOTE: Removal steps in this Service Instruction may contain installation details.**

1. Remove the Sun Visor (see TOPIx Workshop Manual, section 501-05).

2. **NOTE: The step must be carried out on both sides.**

Remove both A-pillar trim panels (see TOPIx Workshop Manual, section 501-05).

3. **NOTE: The step must be carried out on both sides.**

Remove both B-pillar trim panels (see TOPIx Workshop Manual, section 501-05).

4. **NOTE: The step must be carried out on both sides.**

Remove both C-pillar trim panels (see TOPIx Workshop Manual, section 501-05).

5. **NOTE: The step must be carried out on both sides.**

Remove both D-pillar trim panels (see TOPIx Workshop Manual, section 501-05).

6. Remove the overhead console (see TOPIx Workshop Manual, section 501-12).

7.  **NOTE: Note the orientation of the seal prior to detaching.**

Reposition the tailgate seal.

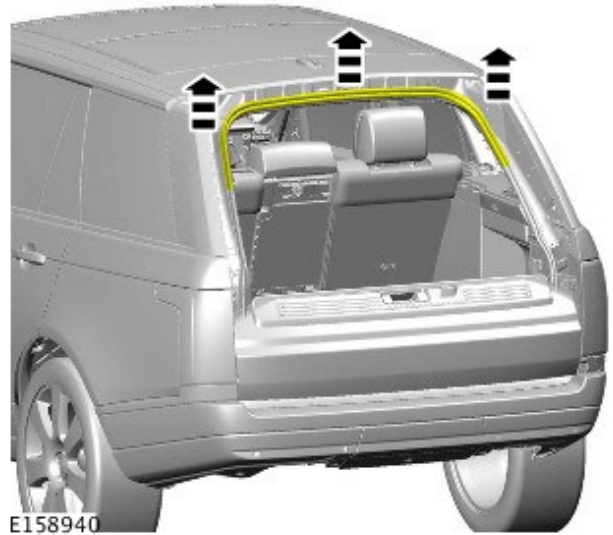

8.  **NOTE: The step must be carried out on both sides.**

Remove the roof handle and position the front door seal to one side.

- Torque: 6 Nm

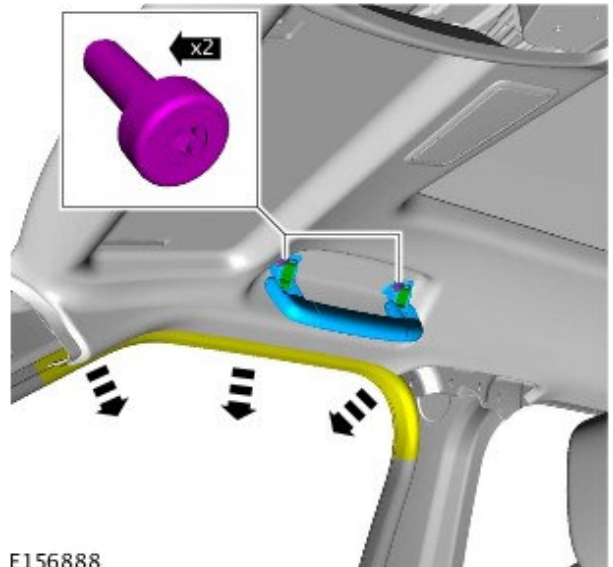

9.  **NOTE: The step must be carried out on both sides.**

Remove the roof handle and position the rear door seal to one side.

- Torque: 6 Nm

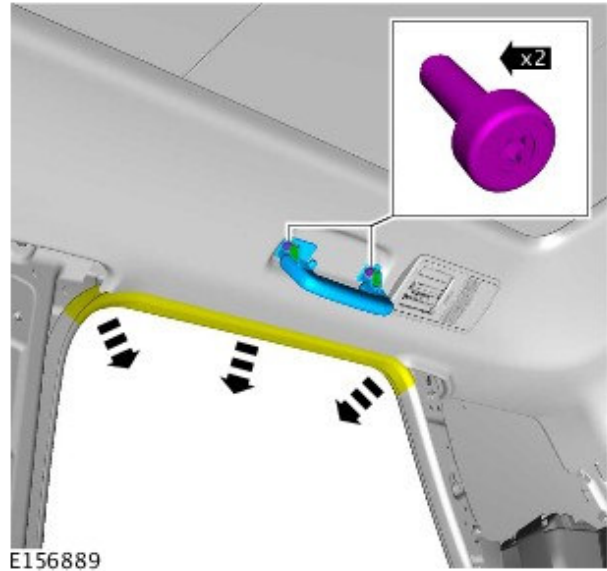

10.  **NOTE: The step must be carried out on both sides.**

Remove the interior lamp cover.

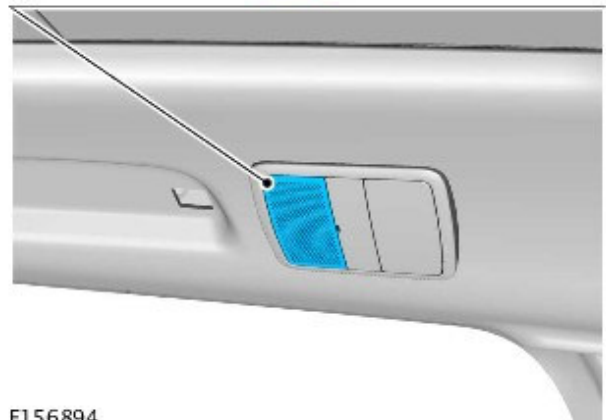

11.  **NOTE: The step must be carried out on both sides.**

Remove the interior lamp cover retaining bolt.

- Torque: 6 Nm

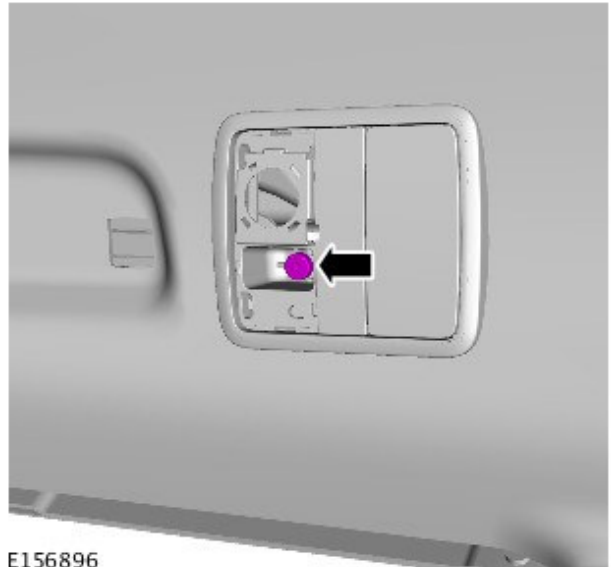

E156896

12.  **NOTE: The step must be carried out on both sides.**

 **NOTE: If equipped.**

Remove the roof air vents.

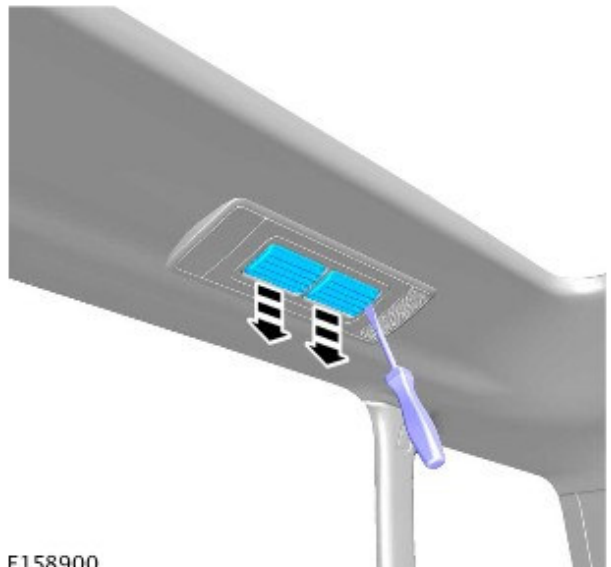

E158900

13.  **NOTE: The step must be carried out on both sides.**

 **NOTE: If equipped.**

Remove the roof air vent fixings.

- Torque: 6 Nm



14.  **CAUTION: Take extra care not to damage the component.**

 **NOTE: The step must be carried out on both sides.**

 **NOTE: If equipped.**

Detach the headliner retainers as illustrated.

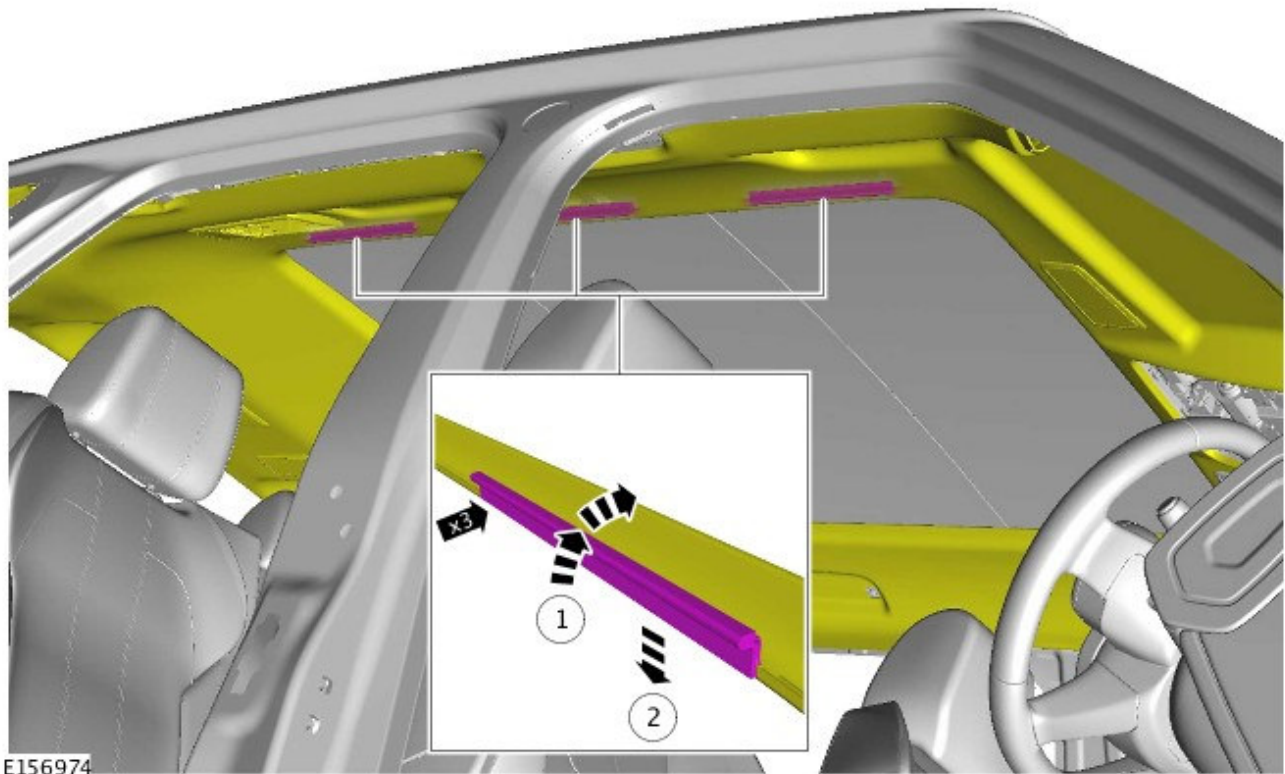

E156974

15.  **CAUTION: Take extra care not to damage the component.**

 **CAUTION: Using a suitable plastic trim tool, release the magnetic fixings.**

 **CAUTION: Make sure that there is at least 50mm clearance between the magnetic fixings and the headliner during the removal procedure. The fixings will engage if too close to each other.**

Remove the headliner retaining clips as shown.

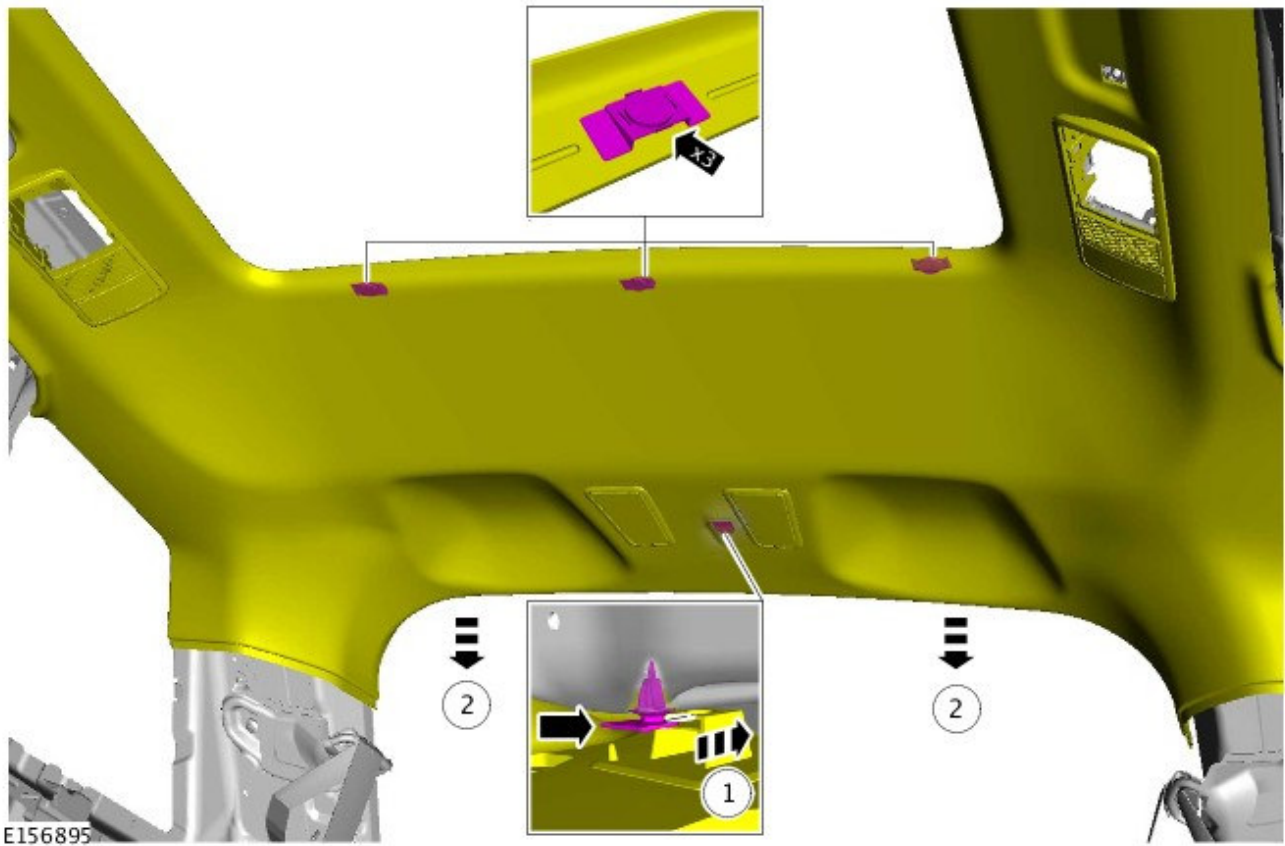

**16.** Remove the headliner retaining clips as illustrated.

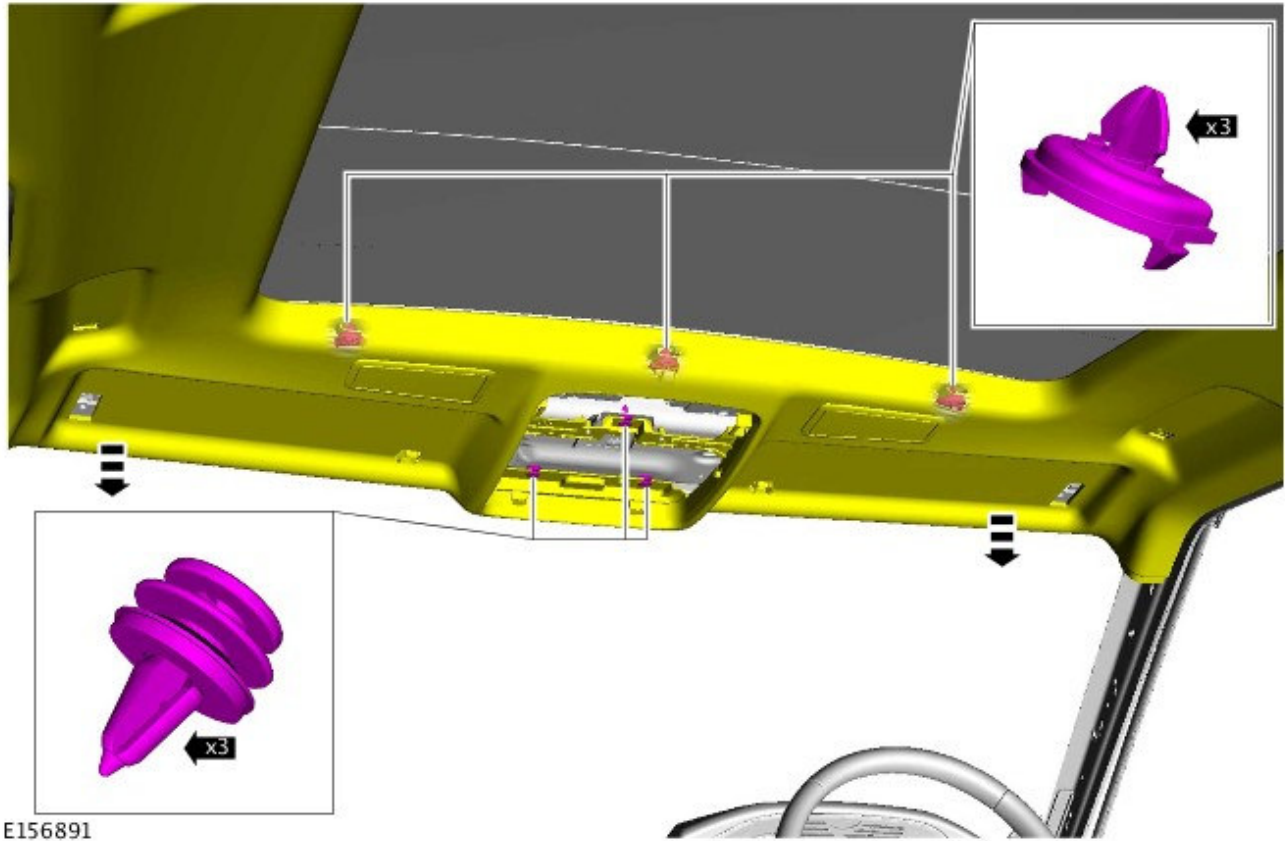

E156891

17.  **CAUTION:** Take extra care not to damage the component.

Lower the headliner.

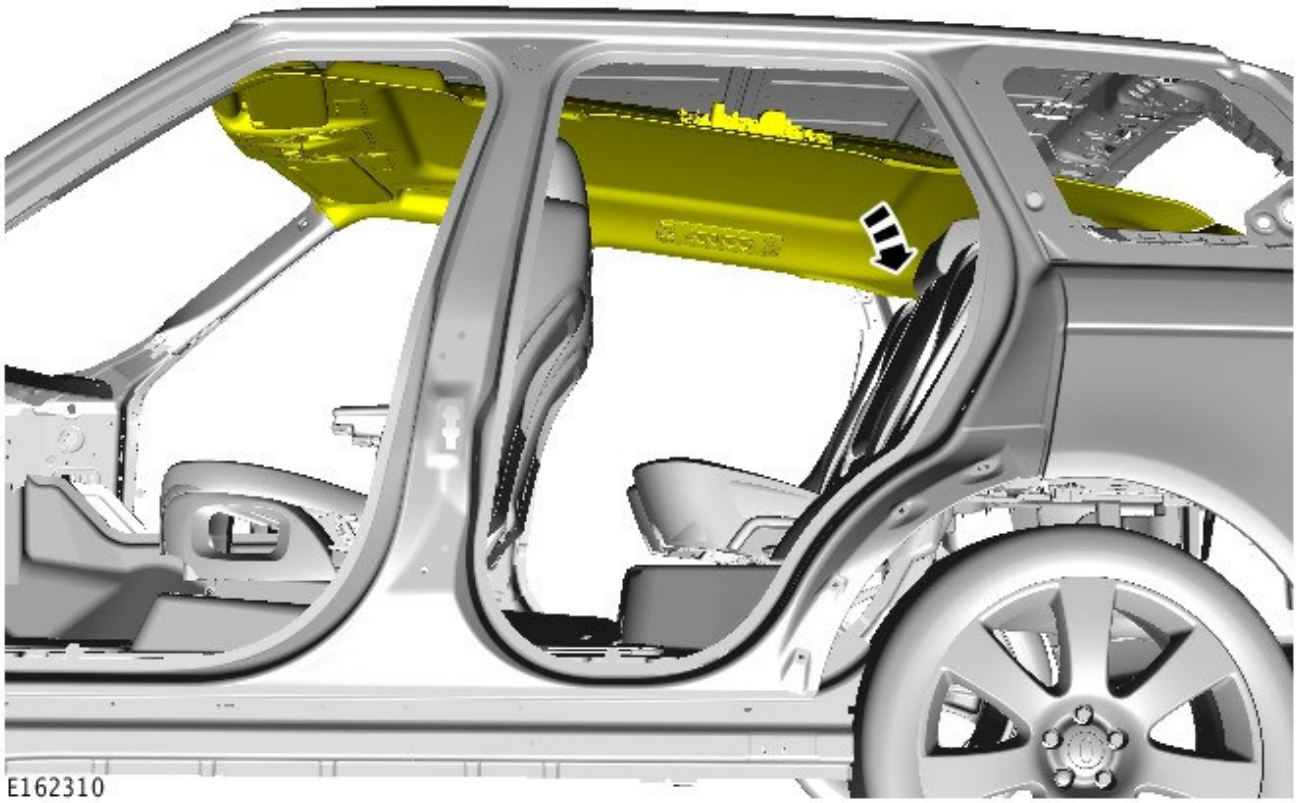

**18.** Disconnect the electrical connector C44-R2 from C44-R1.

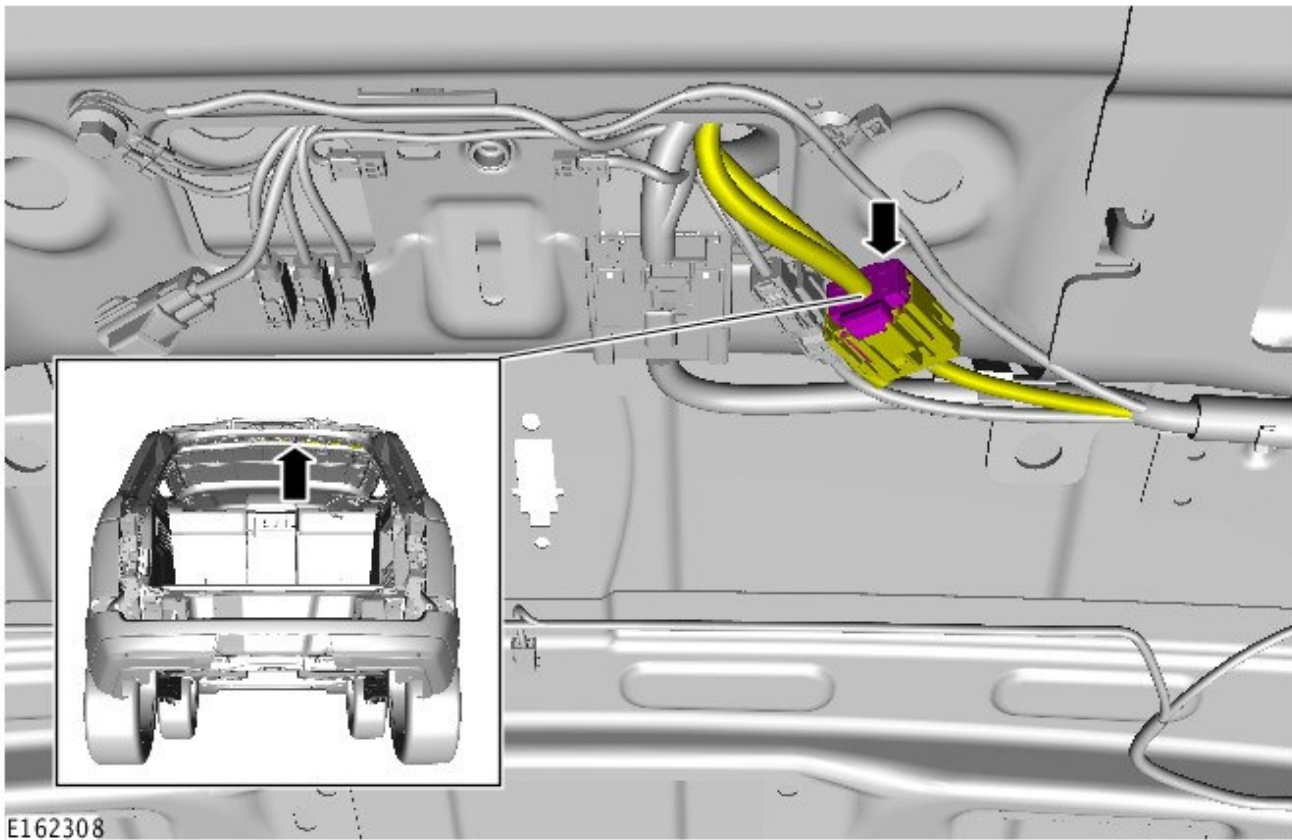

19. Remove the terminals in the positions 10, 17, 18, and 21 and carry out a pin drag test with each corresponding terminal of connector C44-R1.

- If any of the terminals show no sign of resistance to movement during the test, continue to step 20.
- If any of the terminals offer a small amount of resistance, refit the original terminals to connector C44-R2 and carry out a continuity test across the two connectors.
- If the joint has good continuity, continue with further diagnosis with reference to TOPIX and SDD.

20. **⚠ CAUTION: To reduce the chance of incorrect wiring of the harness, repair only one wire at a time.**

Carry out the wiring repair (see TOPIX Workshop Manual section 418-02). Remove any terminals found to be faulty by diagnosis in step 19 and install a new terminal as required (41841145). Make sure a sufficient length of wire is left on the electrical harness so the new terminal can be installed correctly using the recommended splice connector (418107). Make sure the correct black identification sleeve (418112) is fitted to the new terminal.

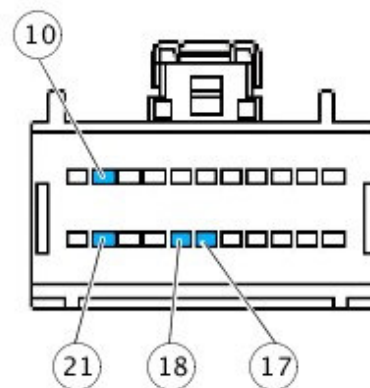

E162309

- 21.** Install connector C44-R2 to C44-R1 and check for correct continuity across the connector before continuing.
- 22.** To install, reverse steps 1-17.