



# Service Bulletin

## CUSTOMER SATISFACTION PROGRAM

**Subject:** 09132E – Power Steering Hose Leak (Program Expired)

**Models:** 2006 Chevrolet Impala, Monte Carlo (V6 & V8 Engine)  
2005-2006 Pontiac Grand Prix (V8 Engine)

*The expiration date of this bulletin is being extended to February 28, 2015. Discard all copies of bulletin 09132D.*

THIS PROGRAM EXPIRED.

### Condition

**Certain** 2006 model Chevrolet Impala and Monte Carlo vehicles equipped with a V6 or V8 engine, and 2005 and 2006 model year Pontiac Grand Prix vehicles equipped with a V8 engine may have a condition in which the power steering cooler line may leak or split. When these vehicles are started in cold weather, the pressure on the hose is substantially higher than in warmer weather and may exceed the strength of the power steering hose or clamps. If this were to occur, the driver would likely notice fluid spotting under the vehicle when the vehicle is parked and a decrease in the power steering assist. If enough fluid were lost, damage to the power steering pump could occur.

### Correction

Dealers are to replace the power steering hose assembly on vehicles with a V8 engine, or replace a length of hose and clamps on vehicles with a V6 engine.

### Vehicles Involved

Involved are **certain** 2006 model Chevrolet Impala and Monte Carlo vehicles equipped with a V6 or V8 engine, and 2005 and 2006 model year Pontiac Grand Prix vehicles equipped with a V8 engine, and built within these VIN breakpoints:

Year	Division	Model	From	Through
2006	Chevrolet	Impala	69100003	69438808
2006	Chevrolet	Monte Carlo	69100406	69438794
2005	Pontiac	Grand Prix	51230922	51356980
2006	Pontiac	Grand Prix	61100004	61315421

**Important:** Dealers are to confirm vehicle eligibility prior to beginning repairs by using Investigate Vehicle History. Not all vehicles within the above breakpoints may be involved.

For dealers with involved vehicles, a listing with involved vehicles containing the complete vehicle identification number, customer name, and address information has been prepared and will be provided to dealers through the GM GlobalConnect Recall Reports. Dealers will not have a report available if they have no involved vehicles currently assigned.

The listing may contain customer names and addresses obtained from Motor Vehicle Registration Records. The use of such motor vehicle registration data for any purpose other than follow-up necessary to complete this program is a violation of law in several states/provinces/countries. Accordingly, you are urged to limit the use of this report to the follow-up necessary to complete this program.

### Parts Information

Parts required to complete this program are to be obtained from General Motors Customer Care and Aftersales. Please refer to your “involved vehicles listing”

before ordering parts. Normal orders should be placed on a DRO = Daily Replenishment Order. In an emergency situation, parts should be ordered on a CSO = Customer Special Order.

Part Number	Description	Qty/ Vehicle
25793853	Pipe, P/S Fluid Clg (V6)	1
25793936	Clamp, P/S Gr Otlt P/S Fluid Rsvr Inl Hose (V6)	2
19177770	Pipe Kit, P/S Fluid Clg (V8 Impala/Monte Carlo)	1
19177771	Pipe Kit, P/S Fluid Clg (V8 Grand Prix)	1
10125439 Note: P/N 11516301, which is called out in kit instruction sheet, is not available	Rivet, Flat Hd (V8)	1
12345632 (US) 10953475 (Canada)	Adhesive Gel, Instant (or equivalent, such as SAF-T- LOK IB-45 (ETHILCIANOCRILATO) (V8)	1
89020661 (US) 89021186 (CN)	Fluid, Hydraulic Power Steering (32 oz)	V6 - ¼ container (submit as Net Item)  V8 - 1 container (submit under Part Quantity)

## Service Procedure

### V6 Engine

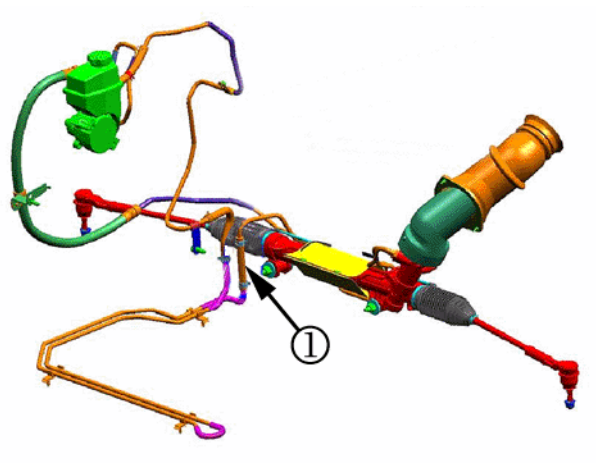

**Note:** The location of the leak (1) is shown above. The power steering cooler hose may leak from the hose clamp.

1. Raise and support the vehicle. Refer to the Lifting and Jacking the Vehicle procedure in SI.
2. Place a drain pan under the repair area.
3. Remove the power steering hose clamps.
4. Remove the power steering hose from the vehicle.



5. Measure 25 mm (1 in) from both ends of new power steering hose.
6. Mark the new power steering hose measurements with a white or yellow marker as shown in illustration.
7. Apply GM Super Lube®, P/N 12346241, or equivalent to the inside ends of the new power steering hose.
8. Slide the new clamps onto the new power steering hose.
9. Install the new power steering hose.

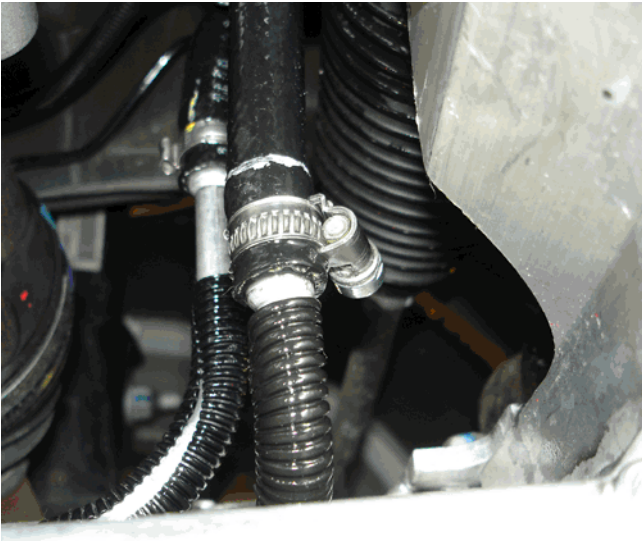

10. Position the power steering hose clamps between the white or yellow measurement lines created in Step 6 and the end of the new hose. **Ensure the clamp is NOT placed over the hard line flare.**
11. Tighten the clamps until the torque cap breaks off of the clamp.
12. Clean the fluid from the underbody of the vehicle.
13. Lower the vehicle.
14. Check the power steering fluid. Add power steering fluid and bleed the system. Refer to the Checking and Adding Power Steering Fluid procedure in SI.

#### V8 Engine

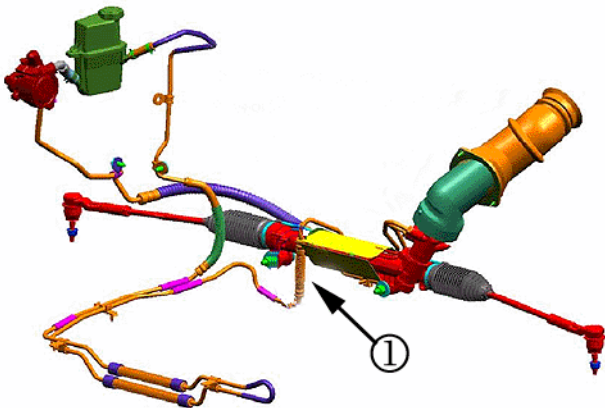

**Note:** The location of the leak (1) is shown above. Fittings on the hose are crimped socket and are not likely to leak.



**Note:**

- Two holes will be drilled for retro-fitting 2006 cradles with 2007 cooler pipe.
- Technician will need to remove one clip from cooler pipe on top and replace with isolator and move the other to the front face of the cradle (and replace with isolator).
- Technician will need to glue down the two isolators with Instant Adhesive-Gel, P/N 12345632 (US), 10953475 (CN), or equivalent, such as SAF-T-LOK IB-45 (ETHILCIANOCRILATO).

1. Raise and support the vehicle. Refer to the Lifting and Jacking the Vehicle procedure in SI.
2. Place a drain pan under the vehicle to capture the power steering fluid when disconnecting the power steering return line.
3. Remove the air deflector.
4. Remove the power steering cooler pipe/hose from the retaining clips on the frame.

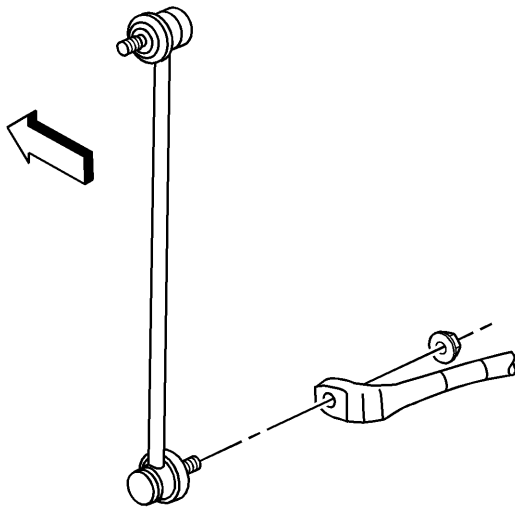

5. Disconnect both stabilizer shaft links from the shaft.

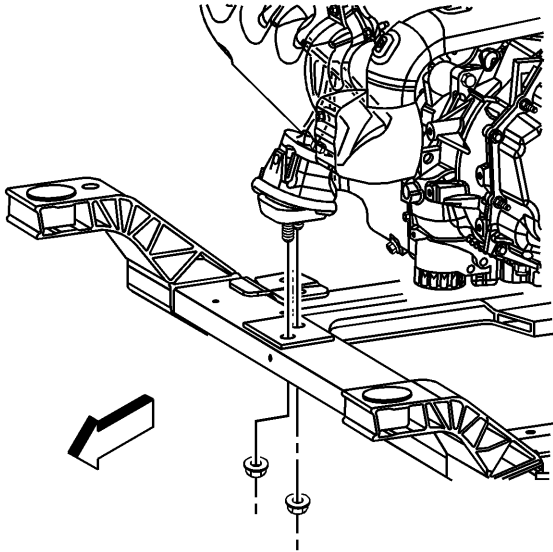

6. Remove the left side engine mount lower nuts from the frame.

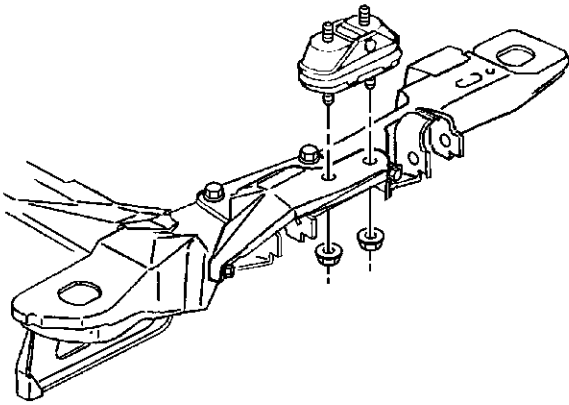

7. Remove the left side transmission mount lower nuts from the frame.

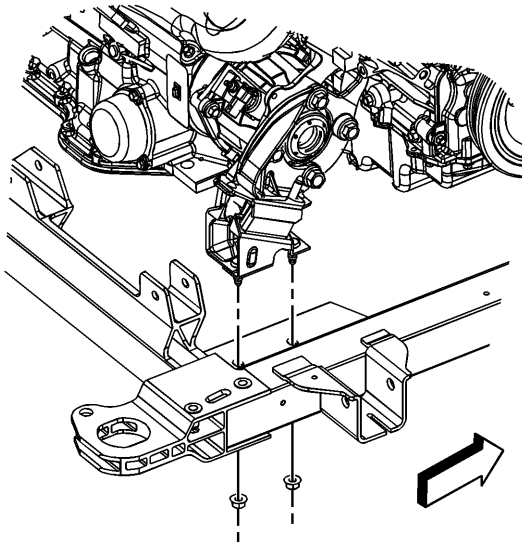

8. Remove the right side engine mount lower nuts from the frame.
  9. Support and raise the transmission. Raise the transmission about 51-76 mm (2-3 in).
  10. Support the rear of the frame (cradle) using an adjustable jackstand.
  11. Remove the rear frame bolts from the frame.
- Caution:** To avoid part damage, do NOT lower the rear frame (cradle) more than 76 mm (3 in).
12. Lower the rear frame (cradle) no more than 76 mm (3 in).

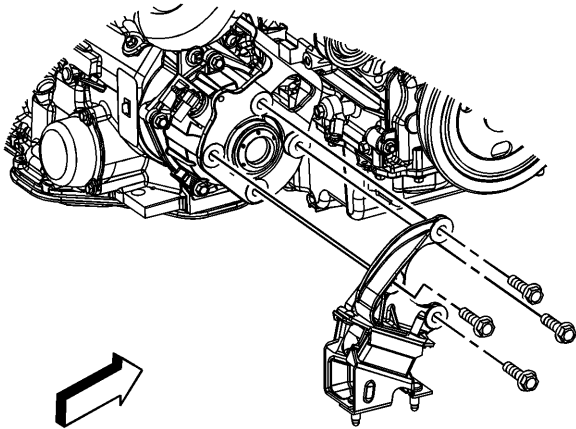

13. Remove the right side engine mount bracket bolts.
14. Remove the right side engine mount and bracket from the vehicle.
15. Disconnect the power steering cooler pipe/hose from the gear.
16. Remove the power steering cooler pipe/hose clamp from the pipe/hose and return line.
17. Disconnect the power steering cooler pipe/hose from the return line.
18. Remove the power steering cooler pipe/hose assembly from the vehicle.
19. Install the power steering cooler pipe/hose assembly to the vehicle with the new cooler installed over the front of the cradle as shown.
20. Connect the power steering cooler pipe/hose to the return line and install the clamp.
21. Connect the power steering cooler pipe/hose to the gear.

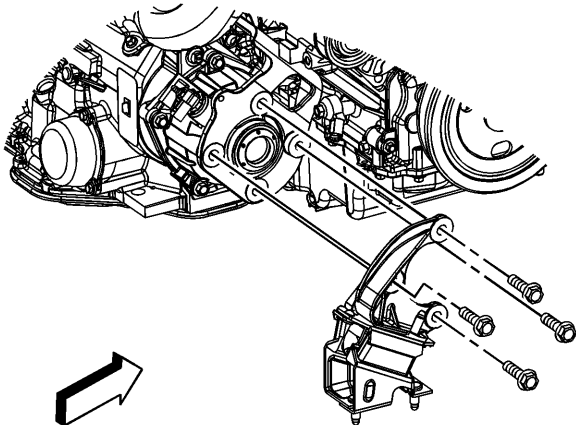

**Note:** Glue should be Instant Adhesive-Gel, P/N 12345632 (US), 10953475 (CN), or equivalent, such as SAF-T-LOK IB-45 (ETHILCIANOCRILATO).

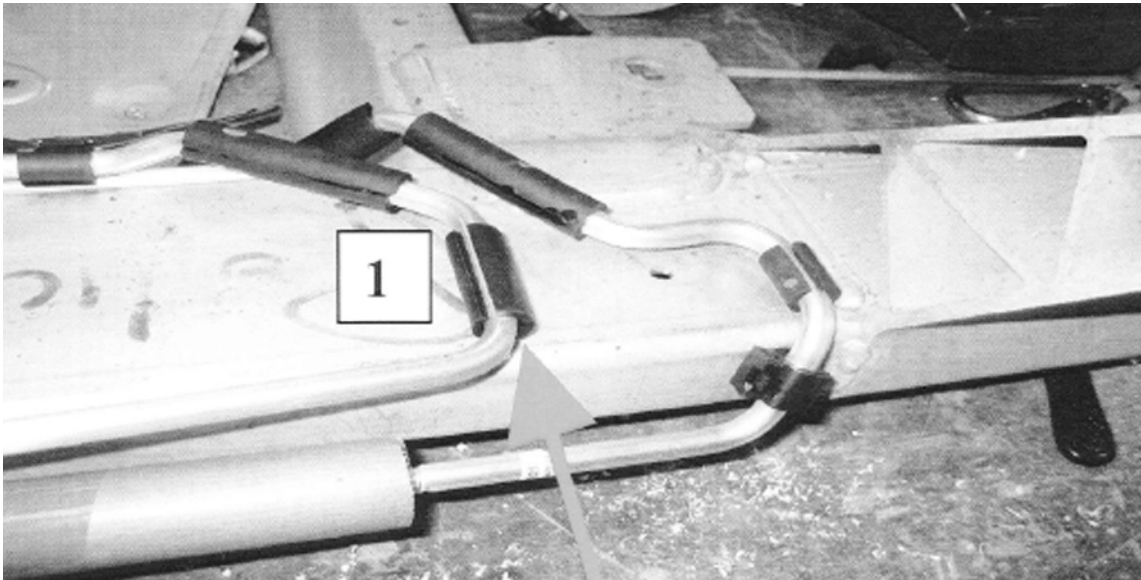

22. Remove the clip and replace with glued isolator (1). Isolator is smaller than what picture shows.

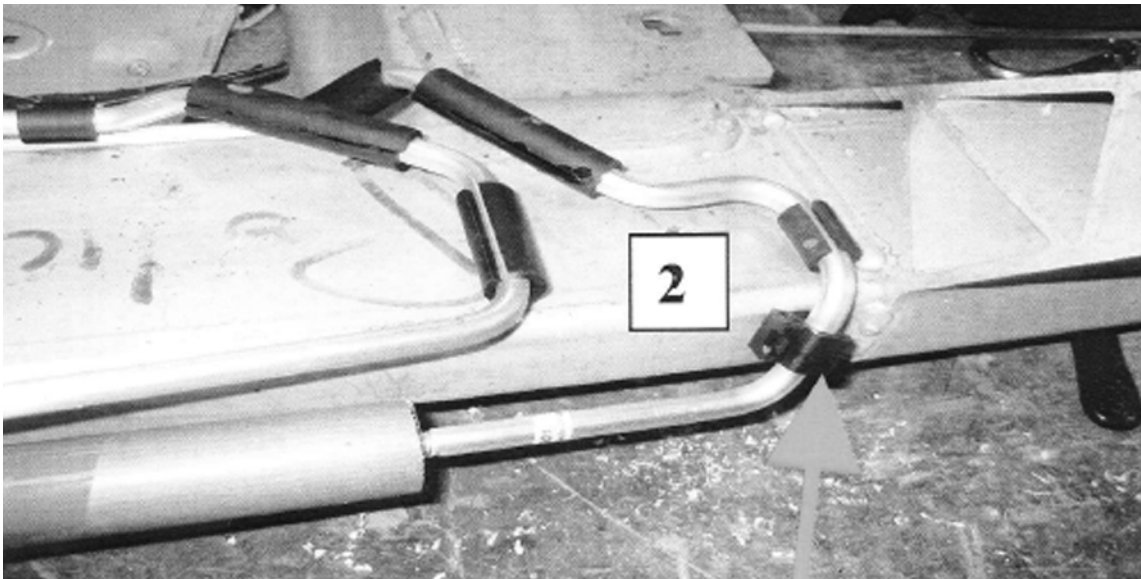

**Note:** Glue should be Instant Adhesive-Gel, P/N 12345632 (US), 10953475 (CN), or equivalent, such as SAF-T-LOK IB-45 (ETHILCIANOCRILATO).

23. Move the other clip to the front of the cradle and replace with glued isolator (2).

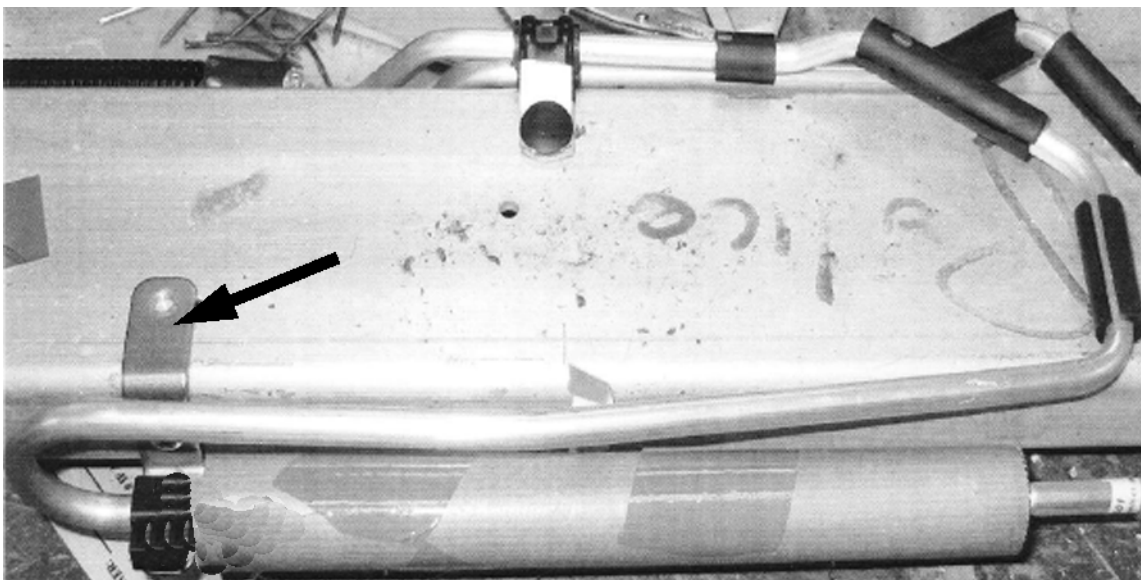

**Note:** The hole should be drilled using a 7/32 in drill bit and is located 402mm (15-13/16 in) from the weld and 19mm (3/4 in) from the top of the cradle.



The z-bracket should be riveted to the cradle using P/N 10125439 (instruction sheet may show P/N 11516301, but it may not be available).

24. Drill a hole in the cradle through the z-bracket.

**Note:** The hole should be drilled using 1/4 in drill bit and is located 40mm (1-9/16 in) from the weld and 16mm (5/8 in) from the top of the cradle.



25. Drill to fit clip in front of cradle (3).
26. Remove the cardboard protector from fin cooler.
27. Install the right side engine mount and bracket to the vehicle.
28. Install the right side engine mount bracket bolts.  
**Tighten:** Tighten the engine mount bracket bolts to 50 Y (37 lb ft).
29. Raise the rear of the frame (cradle) using an adjustable jackstand.
30. Install the rear frame bolts.  
**Tighten:** Tighten the rear frame bolts to 160 Y (118 lb ft).
31. Remove the adjustable jackstand from under the frame.
32. Lower the transmission and remove the support.

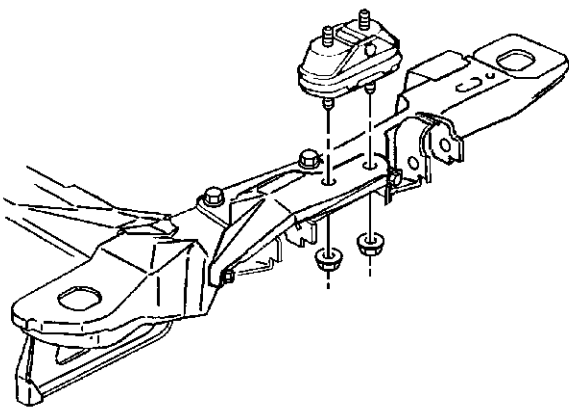

33. Install the left side transmission mount lower nuts to the frame.  
**Tighten:** Tighten the left side transmission mount lower nuts to 47 Y(35 lb ft).

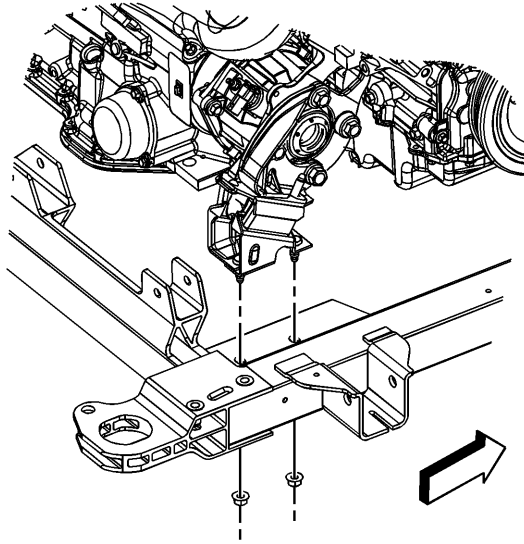

34. Install the right side engine mount lower nuts to the frame.

**Tighten:** Tighten the right side engine mount lower nuts to 50 Y (37 lb ft).

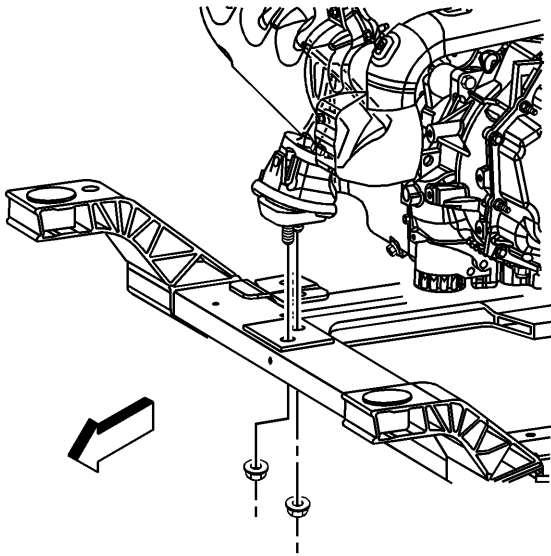

35. Install the left side engine mount lower nuts to the frame.

**Tighten:** Tighten the left side engine mount lower nuts to 50 Y (37 lb ft).

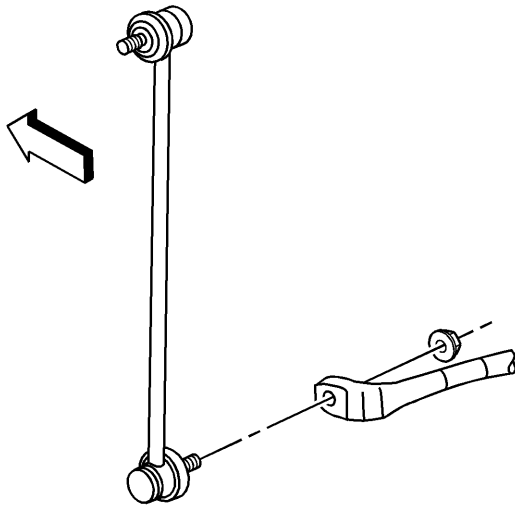

36. Connect both stabilizer shaft links to the shaft.  
**Tighten:** Tighten the stabilizer link nuts to 60 Y (44 lb ft).
37. Install the power steering cooler pipe/hose to the frame mounted retaining clips.
38. Install the air deflector.
39. Clean power steering fluid from the underbody of the vehicle.
40. Remove the drain pan.
41. Lower the vehicle.
42. Check the power steering fluid. Add fluid and bleed the system. Refer to Checking and Adding Power Steering Fluid procedure in SI.

## Customer Reimbursement – For US

All customer requests for reimbursement for previous repairs for the condition will be handled by the Customer Assistance Center, not by dealers.

A General Motors Customer Reimbursement Procedure and Claim Form is included with the customer letter.

**Important:** (For GM Only) Refer to the GM Service Policies and Procedures Manual, section 6.1.12, for specific procedures regarding customer reimbursement and the form.

## Customer Reimbursement – For Canada

Customer requests for reimbursement for previous repairs for the condition are to be submitted to the dealer by February 28, 2013.

All reasonable customer paid receipts should be considered for reimbursement. The amount to be reimbursed will be limited to the amount the repair would have cost if completed by an authorized General Motors dealer.

When a customer requests reimbursement, they must provide the following:

- Proof of ownership at time of repair.
- Original paid receipt confirming the amount of repair expense(s) that were not reimbursed, a description of the repair, and the person or entity performing the repair.

Claims for customer reimbursement on previously paid repairs are to be submitted as required by WINS.

**Important:** Refer to the GM Service Policies and Procedures Manual, section 6.1.12, for specific procedures regarding customer reimbursement verification.

## Courtesy Transportation

The General Motors Courtesy Transportation program is intended to minimize customer inconvenience when a vehicle requires a repair that is covered by the New Vehicle Limited Warranties. The availability of courtesy transportation to customers whose vehicles are within the warranty coverage period and involved in a product program is very important in maintaining customer satisfaction. Dealers are to ensure that these customers understand that shuttle service or some other form of courtesy transportation is available and will be provided at no charge. Dealers should refer to the General Motors Service Policies and Procedures Manual for Courtesy Transportation guidelines.

## Warranty Transaction Information

Submit a transaction using the table below.

Labor Operation	Description	Labor Time	Part Count	Net Item
Program Expired	Replace Power Steering Hose & Clamps (inc. system bleed) (V6)	0.5	3	*
Program Expired	Replace Power Steering Cooler Line (inc. system bleed) (V8)	1.7	4	N/A
Program Expired	Customer Reimbursement (not for use by US GM dealers)	0.2	N/A	**

\* The amount identified in "Net Item" should represent the actual sum total of the current GMCC&A Dealer net price for the ¼ container of power steering fluid (V6) needed to perform the required repairs, not to exceed \$1.40 USD, \$1.26 CAD, plus applicable Mark-Up.

\*\* The amount identified in "Net Item" should represent the dollar amount reimbursed to the customer.

## Customer Notification

General Motors will notify customers of this program on their vehicle (see copy of customer letter included with this bulletin).

## Dealer Program Responsibility

All unsold new vehicles in dealers' possession and subject to this program must be held and inspected/repared per the service procedure of this program bulletin before customers take possession of these vehicles.

Dealers are to service all vehicles subject to this program at no charge to customers, regardless of mileage, age of vehicle, or ownership, through February 28, 2015.

Customers who have recently purchased vehicles sold from your vehicle inventory, and for which there is no customer information indicated on the dealer listing, are to be contacted by the dealer. Arrangements are to be made to make the required correction according to the instructions contained in this bulletin. A copy of the customer letter is provided in this bulletin for your use in contacting customers. Program follow-up cards should not be used for this purpose, since the customer may not as yet have received the notification letter.

In summary, whenever a vehicle subject to this program enters your vehicle inventory, or is in your dealership for service through February 28, 2015, you must take the steps necessary to be sure the program correction has been made before selling or releasing the vehicle.

### Generic Owner Letter

Dear General Motors Customer:

We have learned that your 2005 or 2006 model year Pontiac Grand Prix or 2006 model year Chevrolet Impala or Monte Carlo, may have a condition in which the power steering cooler line may leak or split. If this were to occur, you would likely notice fluid spotting under the vehicle when the vehicle is parked and a decrease in the power steering assist. If enough fluid were lost, damage to the power steering pump could occur.

Your satisfaction with your 2005 or 2006 model year Pontiac Grand Prix or 2006 model year Chevrolet Impala or Monte Carlo is very important to us, so we are announcing a program to prevent this condition.

**What We Will Do:** Your GM dealer will replace the power steering cooler line on your vehicle. This service will be performed for you **at no charge until February 28, 2015**. (extended to February 28, 2015; new letters not sent)

**What You Should Do:** To limit any possible inconvenience, we recommend that you contact your dealer as soon as possible to schedule an appointment for this repair. By scheduling an appointment, your dealer can ensure that the necessary parts will be available on your scheduled appointment date.

**Reimbursement:** The enclosed form explains what reimbursement is available and how to request reimbursement if you have paid for repairs for this condition. Your request for reimbursement, including the information and documents mentioned on the enclosed form, must be received by GM by February 28, 2011. Because you have already had the hose replaced, you do not need to take your vehicle to your dealer for this repair. If you have any questions or need any assistance to better understand related repairs, please contact your dealer.

If you have questions related to a potential reimbursement, please contact the appropriate Customer Assistance Center at the number listed below.

Division	Number	Text Telephones
Chevrolet	1-800-630-2438	1-800-833-2438
GMC	1-866-996-9463	1-800-462-8583

Guam	1-671-648-8450	
Puerto Rico – English	1-800-496-9992	
Puerto Rico – Español	1-800-496-9993	
Virgin Islands	1-800-496-9994	

We sincerely regret any inconvenience or concern that this situation may cause you. We want you to know that we will do our best, throughout your ownership experience, to ensure that your GM vehicle provides you many miles of enjoyable driving.

Scott Lawson

Director,  
Customer and Relationship Services

Enclosure

09132

---

GM bulletins are intended for use by professional technicians, NOT a "do-it-yourselfer". They are written to inform these technicians of conditions that may occur on some vehicles, or to provide information that could assist in the proper service of a vehicle. Properly trained technicians have the equipment, tools, safety instructions, and know-how to do a job properly and safely. If a condition is described, DO NOT assume that the bulletin applies to your vehicle, or that your vehicle will have that condition. See your GM dealer for information on whether your vehicle may benefit from the information.



WE SUPPORT VOLUNTARY TECHNICIAN CERTIFICATION

GM CUSTOMER CARE AND AFTERSALES  
DCS3142  
URGENT - DISTRIBUTE IMMEDIATELY

Date: February 25, 2014

Subject: 09132E – Customer Satisfaction Program  
Power Steering Hose Leak  
Expiration Date Extended

Models: 2006 Chevrolet Impala, Monte Carlo (V6 & V8 Engine); 2005-06  
Pontiac Grand Prix (V8 Engine)

To: All Buick, Cadillac, Chevrolet, and GMC Dealers

Attention: General Manager, Service Advisor, Service Manager, Parts and  
Service Director, Parts Manager, New Vehicle Sales Manager,  
and Warranty Administrator

The expiration date for Customer Satisfaction Program 09132E has been  
extended to February 28, 2015. Please discard all copies of bulletin 09132D.

END OF MESSAGE  
GM CUSTOMER CARE AND AFTERSALES