



# Service Bulletin

File in Section: -

Bulletin No.: PIP4568Q

Date: January, 2014

## PRELIMINARY INFORMATION

**Subject:** Tick Noise And/Or Misfires On AFM Cylinders 1 4 6 And/or 7

**Models:** 2008-2009 Buick LaCrosse, Allure (Canada Only)  
2007 Buick Rainier  
2007-2014 Cadillac Escalade  
2011-2014 Caprice PPV  
2010-2014 Chevrolet Camaro SS  
2007-2013 Chevrolet Silverado  
2007-2014 Chevrolet Avalanche, Suburban, Tahoe  
2006-2009 Chevrolet Trailblazer  
2006-2009 Chevrolet Impala SS  
2006-2007 Chevrolet Monte Carlo SS  
2006-2009 GMC Envoy  
2007-2013 GMC Sierra  
2007-2014 GMC Yukon  
2008-2009 Pontiac G8  
2005-2008 Pontiac Grand Prix GXP  
2006-2009 Saab 97x  
With a V8 Engine and AFM (Active Fuel Management):  
RPO Codes L76, L77, L94, L99, LC9, LFA, LH6, LMG, LS4, LY5, LZ1

**This PI was superseded to add labor time information. Please discard PIP4568P.**

The following diagnosis might be helpful if the vehicle exhibits the symptom(s) described in this PI.

### Condition/Concern

Some customers may comment on an SES light, engine misfire on cylinder 1, 4, 6, or 7 and/or tick noise.

This may be the result of an AFM lifter that unlocks as soon as the engine is started or one that is mechanically collapsed/stuck all of the time.

If an AFM lifter unlocks as soon as the engine is started, low compression will be found on that cylinder during an AFM compression test, along with a SES light, DTC P0300, and engine misfires on the related cylinder but it is unlikely that any noise will be experienced.

If an AFM lifter is mechanically collapsed/stuck, low compression will be found on that cylinder during an AFM compression test, along with a consistent valve train tick noise, SES light, DTC P0300 and engine misfires on the related cylinder.

These lifter concerns may be the result of internal locking pin damage, which may occur if the response time of an AFM lifter unlocking event is decreased due to low oil pressure, oil aeration, internal engine sludge, or an internal concern with an AFM lifter, VLOM, plastic lifter guide, lifter bore, and/or cam lobe wear.

## Recommendation/Instructions

If SI diagnosis does not isolate the cause of this concern, perform the following diagnostic steps as necessary:

1. Perform a Cylinder Deactivation (Active Fuel Management) System Compression Test in SI. If the running compression of the misfiring cylinder stays below 25 PSI regardless of the AFM solenoid being commanded on or off, an AFM lifter is mechanically collapsed/stuck or unlocking as soon as the engine is started.
2. Perform the Cylinder Deactivation (Active Fuel Management) Valve Lifter Oil Manifold Diagnosis and Testing in SI. If the test above isolated a possible AFM lifter concern, it will lead to this test, which tests the VLOM (Valve Lifter Oil Manifold) for proper operation. SI states a limited amount of air will leak from the bleed holes and outlet ports even when the solenoids are off, compare the amount of leakage to verify all 4 solenoids are operating the same. If it isolates a concern with the VLOM, replace it and reevaluate the concern.
3. The AFM lifters can also be monitored for proper operation by carefully inspecting the cylinder 1, 4, 6, and 7 rockers and valves while cranking or briefly and safely running the engine with the valve covers removed in the service bay. If the valve(s) of an AFM cylinder stop moving while doing this test, the AFM lifter is causing the concern.

**Notice:** If SI diagnosis or any of the steps above indicate that any AFM lifters are unlocking or collapsed as described above, follow the applicable notes below and replace the VLOM, all AFM lifters, and all plastic lifter guides.

- Reprogram the ECM with the latest calibrations if you are working on a 2008-2009 Full Size Truck/SUV or a 2007-2009 Chevrolet Tahoe with the Police Package.
- On the 2008-2009 Pontiac G8, 2010-2011 Camaro, and 2007-2010 Full Size Trucks with AFM, also determine if the AFM pressure relief valve shield that is listed in the latest version of 10-06-01-008 has ever been installed for anything else. If not, remove the oil pan and install the AFM shield. If the shield has been installed before, disregard this step. On Passenger Cars with the LS4 engine, determine if the updated oil pan gasket that is listed in the latest version of 11-06-01-007 has ever been installed. If not, remove the oil pan and install this updated oil pan gasket. It is also important to thoroughly clean the inside of the oil pan while it is removed. Due to oil pan differences, this shield and gasket will not fit Mid-Size Utility Vehicles with the LH6 Engine.
- Carefully inspect the camshaft lobes through the lifter bores with a pen light or bore scope to ensure that they are not obviously worn. It is suggested to rotate the crankshaft and camshaft so the entire circumference of all cam lobes can be inspected. Also inspect the lifter bores for any obvious scoring/damage that could be a concern.
- When reassembling, ensure that the lifters are properly aligned to the new plastic lifter guides before they are installed. If they are not aligned properly, it may damage the plastic lifter guide once it is torqued, which may allow the lifter to turn in the guide.
- Clean out the related lifter control oil passages (item 1 below) while the old lifters are removed. Generally, it is only necessary to blow through the passages with shop air but if a lot of debris is noted, it may also be necessary to flush the passages out with brake cleaner. The oil should be changed after doing this since the cylinder heads will be off to replace the lifters anyhow.
- Low oil pressure to the VLOM can also cause AFM lifter damage. As a result, it is suggested to note the Tech 2 oil pressure parameter at a hot idle. This is located in the Cylinder Deactivation Data List of the Tech 2. Generally most known good vehicles will have around 25 PSI (172 KPA) or greater oil pressure at a hot idle with new engine oil. As long as there are no oil pressure sensor DTCs, such as a P0522 or P0523, the oil pressure sensor is fairly accurate. If the sensor reads 19 PSI (131 KPA) or less while at a hot idle with new oil, also perform the Cylinder Deactivation (Active Fuel Management) Oil Pressure Relief Valve Diagnosis and Testing as outlined in SI and repair as necessary. In some cases, the new VLOM could correct a low oil pressure concern if there is an internal leak or plugged VLOM filter screen.

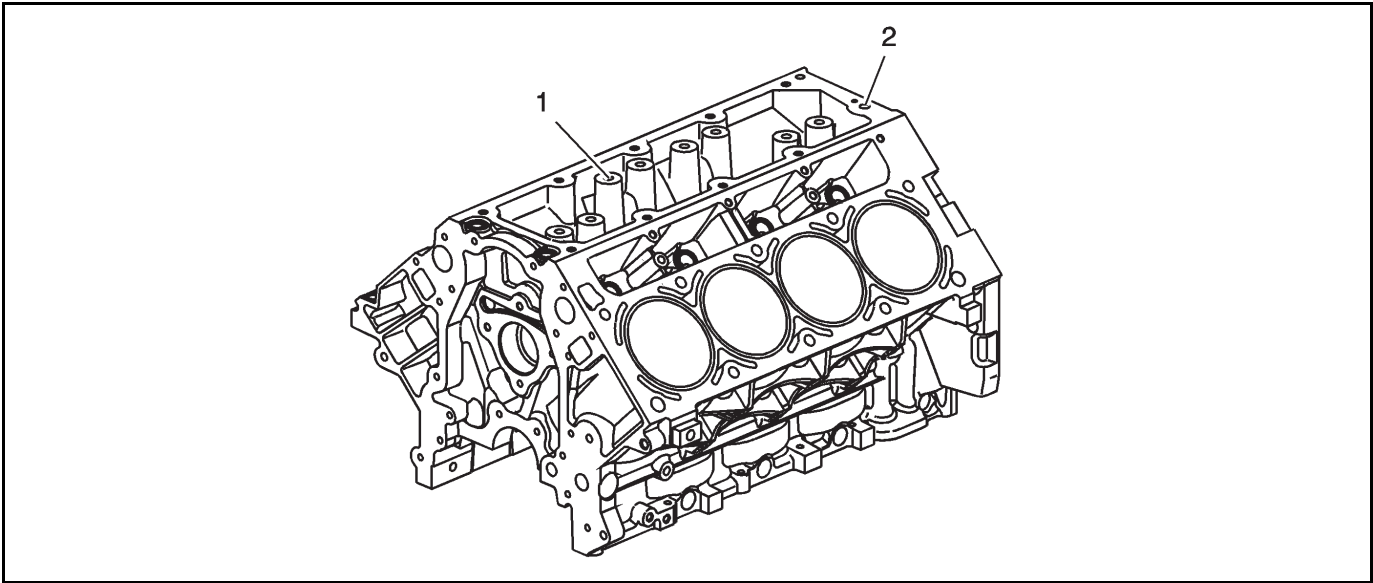

1403340

## Warranty Information

For vehicles repaired under warranty use:

Labor Operation	Description	Labor Time
4062391	Lifter replacement	Use Published Labor Operation Time
2810075	Engine Control module SPS programming	Use Published Labor Operation Time
4065870	Oil Pan replacment	Use Published Labor Operation Time

### ADDITIONAL SI KEYWORDS:

removal replacement installation

Please follow this diagnostic or repair process thoroughly and complete each step. If the condition exhibited is resolved without completing every step, the remaining steps do not need to be performed.