

Front License Place & Mounting Bracket Installation

Service
Category General

Section Pre-Delivery Service

Market USA

Lexus Supports
ASE Certification 

Applicability

YEAR(S)	MODEL(S)	ADDITIONAL INFORMATION
2015	RC350	

Introduction

The Front License Plate Mounting Bracket and two Self-tapping Screws for the 2015 model year RC 350 are placed in the luggage compartment of the vehicle at the assembly plant. For states that require a Front License Plate, install the bracket and bolts on the bumper cover during Pre-Delivery Service (PDS) according to the following procedures.

Warranty Information

OP CODE	DESCRIPTION	TIME	OFF	T1	T2
N/A	Not Applicable to Warranty	-	-	-	-

Front License Place & Mounting Bracket Installation

Installation Procedure

1. Position Front License Mounting Bracket over radiator grille.
2. Align holes "A" of the Mounting Bracket with the dimples on the radiator grille.

NOTE

- Holes "A" are used to install the Mounting Bracket to the radiator grille.
- Holes "B" are used for installation of the Front License Plate to the Mounting Bracket.
- Do NOT pre-drill holes in the dimples.
- Do NOT over-tighten the Self-tapping Screws.

Figure 1.

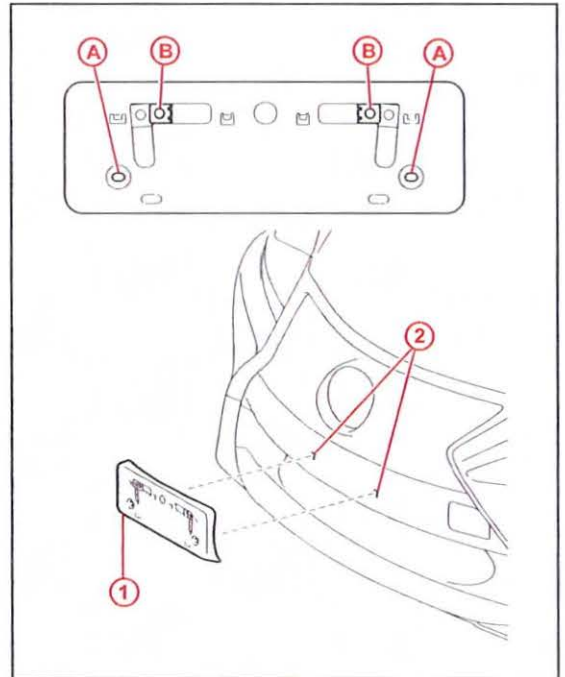

1	Mounting Bracket
2	Dimples

3. Install the Mounting Bracket to the radiator grille at holes "A" using the 2 supplied Self-tapping Screws.

NOTE

- Do NOT pre-drill holes in the dimples.
- Do NOT over-tighten the Self-tapping Screws.

Figure 2.

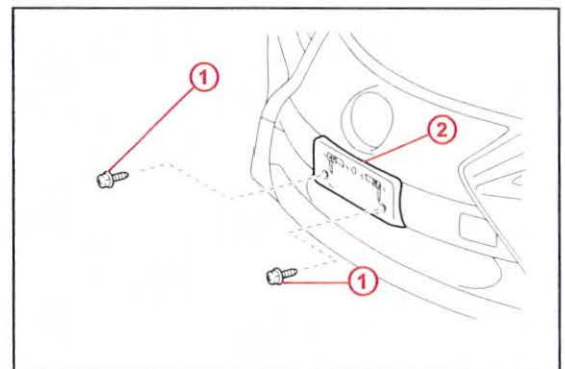

1	Self-tapping Screws into Holes "A"
2	Mounting Bracket

Front License Place & Mounting Bracket Installation

Installation Procedure (Continued)

4. Install the Front License Plate to the Mounting Bracket at holes "B" using two non-corroding bolts with the following dimensions:

Nominal Length: 15.0 mm (0.59 in.)

Diameter: 6.0 mm (0.24 in.)

Figure 3.

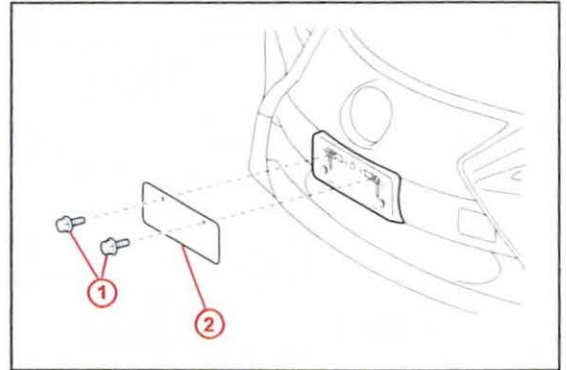

1	Non-corroding bolts into Holes "B"
2	License Plate

Figure 4.

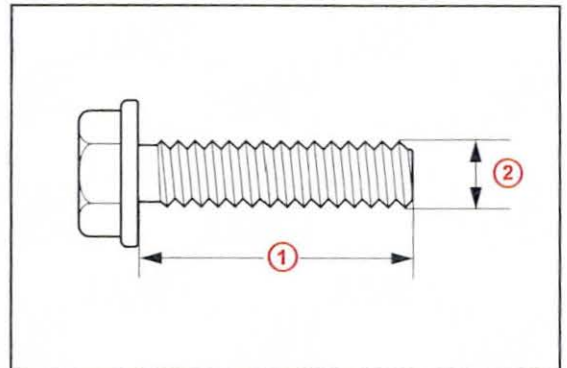

1	Nominal Length
2	Diameter