



Recall Bulletin



PRODUCT SAFETY RECALL

SUBJECT: Passenger Seat Side Impact Airbag

MODELS: 2014 Chevrolet Corvette
Equipped with Competition Sport Seat (RPO AE4)

It is a violation of Federal law for a dealer to deliver a new motor vehicle or any new or used item of motor vehicle equipment (including a tire) covered by this notification under a sale or lease until the defect or noncompliance is remedied.

Vehicles involved in this recall were placed on stop delivery June 11, 2014. Once the service procedure contained in this bulletin has been performed on the vehicle, the vehicle is released from stop delivery and the vehicle can be delivered to the customer.

All involved vehicles that are in dealer inventory must be held and not delivered to customers, dealer traded, or used for demonstration purposes until the repair contained in this bulletin has been performed on the vehicle.

CONDITION

General Motors has decided that a defect which relates to motor vehicle safety exists in certain 2014 model year Chevrolet Corvette vehicles with an optional Sport Seat. The optional Sport Seat in these vehicles contain Side Impact Airbags (SIAB) that, when used in the Sport Seat, do not meet a Technical Working Group (TWG) Side Airbag Injury Assessment Reference Value (IARV) for an unbelted, out-of-position, three-year-old child. General Motors, however, reported to NHTSA that the Corvette with the optional Sport Seat met the TWG IARVs. This information is reported on NHTSA's website www.safercar.gov in the "Meets Side Air Bag Out-of-Position Testing" area. The risk of a neck injury to a three-year-old in a crash who is unbelted, out-of-position, and leaning against the side airbag in the front passenger seat is greater than in a vehicle that meets the TWG criteria.

Drivers should not allow a small child passenger to sit in the right front seat until serviced by the dealer, and should always use proper child restraints.

CORRECTION

Dealers are to replace the passenger side airbag.

VEHICLES INVOLVED

All involved vehicles are identified by Vehicle Identification Number on the Investigate Vehicle History screen in GM Global Warranty Management system. Dealership service personnel should always check this site to confirm vehicle involvement prior to beginning any required inspections and/or repairs. It is important to routinely use this tool to verify eligibility because not all similar vehicles may be involved regardless of description or option content.

For dealers with involved vehicles, a listing with involved vehicles containing the complete vehicle identification number, customer name, and address information has been prepared and will be provided to US and Canadian dealers through the GM GlobalConnect Recall Reports, or sent directly to export dealers. Dealers will not have a report available if they have no involved vehicles currently assigned.

The listing may contain customer names and addresses obtained from Motor Vehicle Registration Records. The use of such motor vehicle registration data for any purpose other than follow-up necessary to complete this recall is a violation of law in several states/provinces/countries. Accordingly, you are urged to limit the use of this report to the follow-up necessary to complete this recall.

PART INFORMATION

Parts Pre-Ship Information – For US and Canada (Export – To Be Determined)

Important: Parts required to complete this service update will be pre-shipped to involved dealers of record. This pre-shipment will take place starting June 18th, 2014 through July 1st, 2014. The pre-shipment will be 100% of each dealer's involved vehicles. Pre-shipped parts will be charged to dealer's open parts account. In the control field you will see "REC14240" for parts that have been pre-shipped for this field action.

Due to the small number of vehicles involved and due to limited initial part availability, dealers will not be allowed to order parts for shelf stock at this time. All orders placed by dealers will be cancelled. For related questions, please contact your District Manager Aftersales (DMA); Canada – District Managers-Customer Care and Aftersales (DMCCA).

Part Number	Description	Quantity/Vehicle
23452489	AIRBAG ASM-F/SEAT OUTBOARD ST BK	1

SERVICE PROCEDURE

3940858

1. Position the passenger seat as shown in the graphic above.
2. Disable the SIR system. Refer to *SIR Disabling and Enabling* in SI.



3940859

3. Remove the passenger seat back airbag opening rear cover (1). Refer to *Front Seat Back Airbag Opening Cover Replacement (Sport-Rear Cover)* in SI.

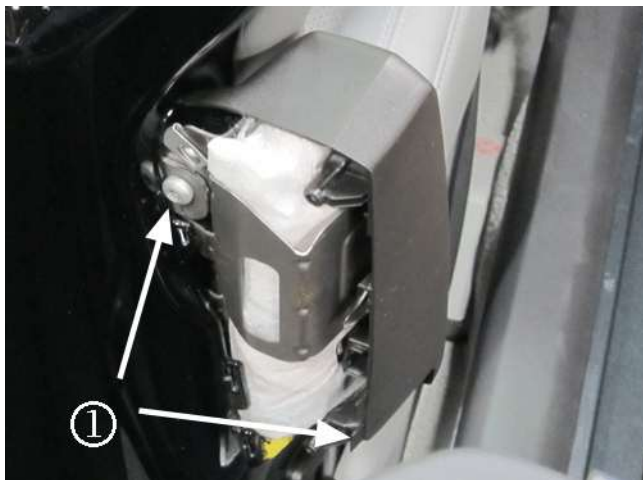

3940860

4. Remove the two retaining bolts (1) and remove the seat back airbag, brackets, and front cover from the seat cushion frame as an assembly.



3940862

5. Disengage the connector position assurance (CPA) (1) from the module electrical connector and disconnect the electrical connector.

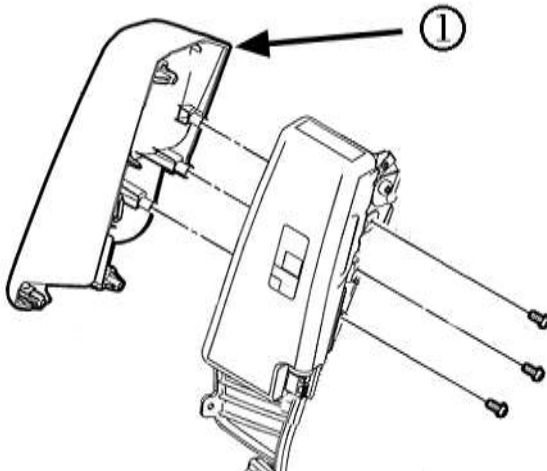

3940888

6. On a workbench, remove the passenger seat back airbag opening front cover (1). Refer to *Front Seat Back Airbag Opening Cover Replacement (Sport-Front Cover)* in SI.

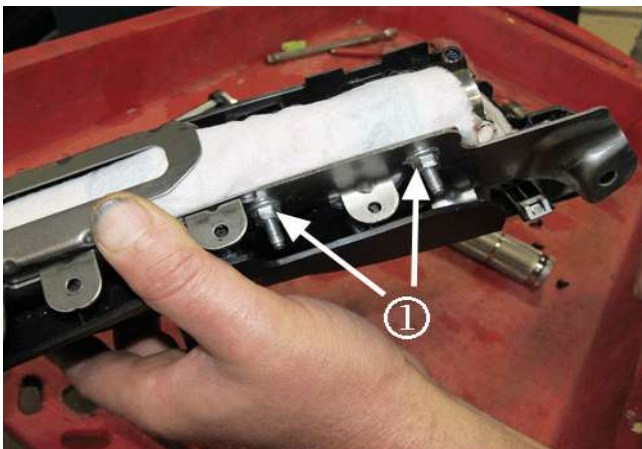

3940863

7. Remove the two nuts (1) retaining the seat back air bag and sleeve bracket to the main bracket.



3940865

- 8. Separate the brackets and remove the airbag.
- 9. Install the new seat back airbag to the sleeve bracket.

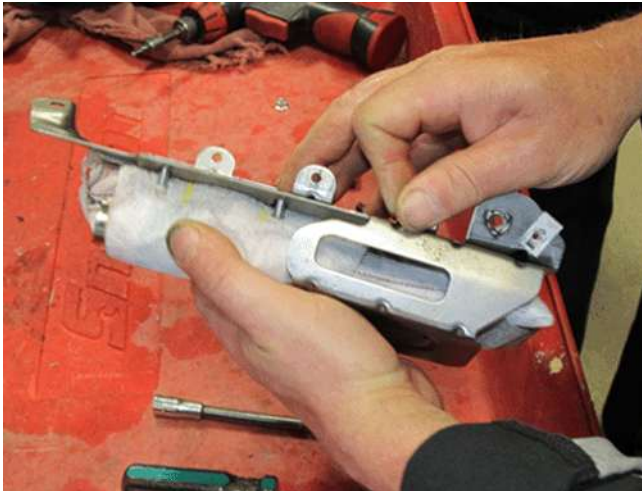

3940866

- 10. Position the sleeve bracket to the main bracket and install the retaining nuts. Tighten the

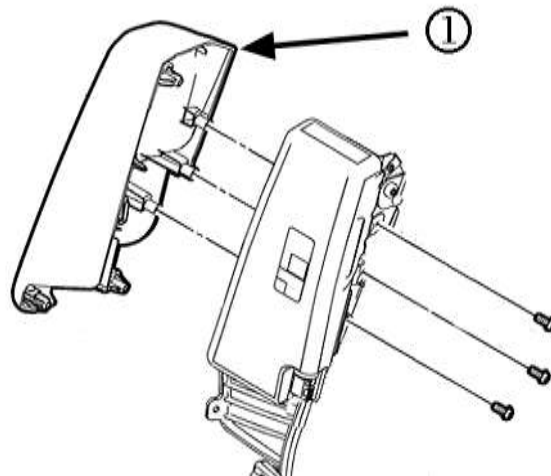

nuts to 4.5 N·m (40 lb in).

3940888

- 11. Install the passenger seat back airbag opening front cover (1). Refer to *Front Seat Back Airbag Opening Cover Replacement (Sport-Front Cover)* in SI.

12. Connect the electrical connector and engage the connector position assurance (CPA) on the module electrical connector.



3940869

13. Position the seat back airbag, brackets, and front cover to the seat cushion frame and install the retaining bolts. Tighten the nuts to 7 N·m (62 lb in).



3940859

14. Install the passenger seat back airbag opening rear (1) cover. Refer to *Front Seat Back Airbag Opening Cover Replacement (Sport-Rear Cover)* in SI.
15. Enable the SIR system. Refer to *SIR Disabling and Enabling* in SI.
16. Program the window motor relearn. Refer to *Window Motor Programming – Express Function* in SI.
17. Refer to *Inflatable Restraint Module Handling and Scrapping* in SI.

FLOOR PLAN REIMBURSEMENT

Dealers in possession of vehicles included in the Stop Delivery are eligible for reimbursement of floor plan expense upon completion of this recall. This reimbursement is limited to the number of days from the Stop Delivery message to receipt of the recall parts and/or repair procedures. Floor plan reimbursement beyond these dates is not allowed. The amount of reimbursement should be charged as a net amount expense using the recall labor operation provided.

COURTESY TRANSPORTATION – For US and Canada

The General Motors Courtesy Transportation program is intended to minimize customer inconvenience when a vehicle requires a repair that is covered by the New Vehicle Limited Warranties. The availability of courtesy transportation to customers whose vehicles are within the warranty coverage period and involved in a product program is very important in maintaining customer satisfaction. Dealers are to ensure that these customers understand that shuttle service or some other form of courtesy transportation is available and will be provided at no charge. Dealers should refer to the General Motors Service Policies and Procedures Manual for Courtesy Transportation guidelines.

WARRANTY TRANSACTION INFORMATION

Submit a transaction using the table below. All transactions should be submitted as a ZFAT transaction type, unless noted otherwise.

Note: To avoid having to "H" route the floor plan transaction for approval, it must be submitted prior to the repair transaction.

Labor Code	Description	Labor Time	Net Item
9100660	Replace Front Passenger Seat Back Airbag (Incl. Deploy Pyrotechnic Device)	0.7	NA
9100661	Floor Plan Reimbursement	N/A	*

* The amount identified in "Net Item" should represent the product of the vehicle's average daily interest rate (see table below) multiplied by the actual number of days the vehicle was in dealer inventory and not available for sale. This reimbursement is limited to the number of days from the date of the stop delivery message (June 11, 2014) to the date the repair is completed and the vehicle is ready for sale (not to exceed 10 days):

Vehicle	US Reimbursement Amount	Canadian Reimbursement Amount
2014 Chevrolet Corvette	\$ 8.42	\$ 10.67

CUSTOMER NOTIFICATION – For US and Canada

General Motors will notify customers of this recall on their vehicle.

CUSTOMER NOTIFICATION – For Export

Letters will be sent to known owners of record located within areas covered by the US National Traffic and Motor Vehicle Safety Act. For owners outside these areas, dealers should notify customers using the attached sample letter.

DEALER RECALL RESPONSIBILITY – For US and Export (US States, Territories, and Possessions)

It is a violation of Federal law for a dealer to deliver a new motor vehicle or any new or used item of motor vehicle equipment (including a tire) covered by this notification under a sale or lease until the defect or noncompliance is remedied.

The US National Traffic and Motor Vehicle Safety Act provides that each vehicle that is subject to a recall of this type must be adequately repaired within a reasonable time after the customer has tendered it for repair. A failure to repair within sixty days after tender of a vehicle is prima facie evidence of failure to repair within a reasonable time. If the condition is not adequately repaired within a reasonable time, the customer may be entitled to an identical or reasonably equivalent vehicle at no charge or to a refund of the purchase price less a reasonable allowance for depreciation. To avoid having to provide these burdensome remedies, every effort must be made to promptly schedule an appointment with each customer and to repair their vehicle as soon as possible. In the recall notification letters, customers are told how to contact the US National Highway Traffic Safety Administration if the recall is not completed within a reasonable time.

DEALER RECALL RESPONSIBILITY – All

All unsold new vehicles in dealers' possession and subject to this recall must be held and inspected/repaired per the service procedure of this recall bulletin before customers take possession of these vehicles.

Dealers are to service all vehicles subject to this recall at no charge to customers, regardless of mileage, age of vehicle, or ownership, from this time forward.

Customers who have recently purchased vehicles sold from your vehicle inventory, and for which there is no customer information indicated on the dealer listing, are to be contacted by the dealer. Arrangements are to be made to make the required correction according to the instructions contained in this bulletin. A copy of the customer letter is provided in this bulletin for your use in contacting customers. Recall follow-up cards should not be used for this purpose, since the customer may not as yet have received the notification letter.

In summary, whenever a vehicle subject to this recall enters your vehicle inventory, or is in your dealership for service in the future, you must take the steps necessary to be sure the recall correction has been made before selling or releasing the vehicle.



