



Program Bulletin



CUSTOMER SATISFACTION PROGRAM

SUBJECT: Passenger Airbag Status Indicator Illumination

MODELS: 2014 Cadillac CTS (VIN A)

Vehicles involved in this recall were placed on stop delivery April 17, 2014. Once the service procedure contained in this bulletin has been performed on the vehicle, the vehicle is released from stop delivery and the vehicle can be delivered to the customer.

All involved vehicles that are in dealer inventory must be held and not delivered to customers, dealer traded, or used for demonstration purposes until the repair contained in this bulletin has been performed on the vehicle.

CONDITION

Certain 2014 model year Cadillac CTS (VIN A) vehicles may have a condition in which the "Passenger Air Bag" wording on the AOS (Automatic Occupant Sensing) display is not back lit. This condition would cause the "Passenger Air Bag" wording to not be visible during nighttime driving, which could result in a driver and/or passenger who is not familiar with the vehicle being unable to tell why the "On" and/or "Off" telltales are being illuminated.

CORRECTION

Dealers are to rework the headliner side of the inline harness to enable illumination of the "Passenger Air Bag" wording.

VEHICLES INVOLVED

All involved vehicles are identified by Vehicle Identification Number on the Investigate Vehicle History screen in GM Global Warranty Management system. Dealership service personnel should always check this site to confirm vehicle involvement prior to beginning any required inspections and/or repairs. It is important to routinely use this tool to verify eligibility because not all similar vehicles may be involved regardless of description or option content.

For dealers with involved vehicles, a listing with involved vehicles containing the complete vehicle identification number, customer name, and address information has been prepared and will be provided to dealers through the GM GlobalConnect Recall Reports. Dealers will not have a report available if they have no involved vehicles currently assigned.

The listing may contain customer names and addresses obtained from Motor Vehicle Registration Records. The use of such motor vehicle registration data for any purpose other than follow-up necessary to complete this program is a violation of law in several states/provinces/countries. Accordingly, you are urged to limit the use of this report to the follow-up necessary to complete this program.

PART INFORMATION

Parts required to complete this program are to be obtained from General Motors Customer Care and Aftersales (GMCC&A). Please refer to your “involved vehicles listing” before ordering parts. Normal orders should be placed on a DRO = Daily Replenishment Order. In an emergency situation, parts should be ordered on a CSO = Customer Special Order.

Part Number	Description	Quantity/Vehicle
11611805	CLIP, W/S UPR GARN/MLDG	1
05297428	CLIP, WRG HARN SPLICE (merch pk of 10)	1
12355001	TUBING, SHRINK (1/4" BLACK) (merch pk of 8)	1
*	WOVEN POLYESTER ELECTRICAL TAPE (PET) P/N 1089482 (preferred)	As Req'd (submit as Net Item)

* To obtain the PET, contact Kent Automotive at 1-888-YES-KENT (1-888-937-5368) and request the special order part number 1089482. **Do not order from GMCCA.**

SERVICE PROCEDURE

Tools Required

- J-38125-8, Splice Sleeve Crimp Tool
 - J-38125-5, Ultratorch, or equivalent butane fueled soldering iron
1. Remove the passenger side windshield garnish molding. Refer to *Windshield Garnish Molding Replacement* in SI.



3902195

2. Locate and disconnect the IP to headliner harness connector.



3902199

3. Working with the headliner side of the in-line, detach the harness connector push pin from the sheet metal, and pull the harness free from the retaining clips along the A-Pillar.
4. Carefully remove approximately 76 mm (3 in) of conduit and tape from the connector end of the harness.

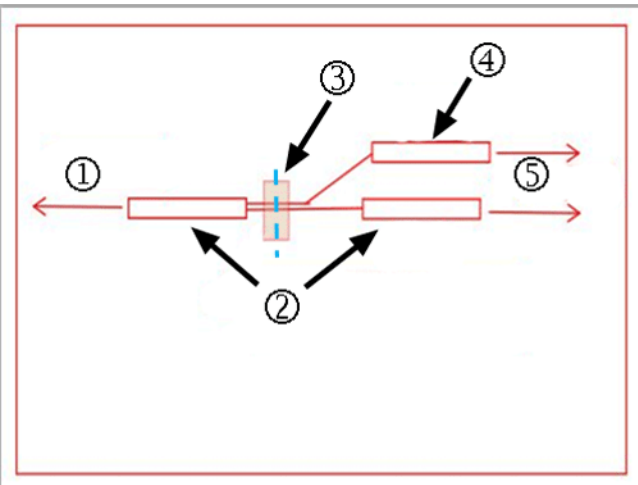

3902204

Note: The illustration above shows a representation of the completed splice.

Key to Call-outs Noted Above

- (1) To connector end
- (2) Circuit 539
- (3) Solder joint and splice clip
- (4) Circuit 1139
- (5) To bundle end

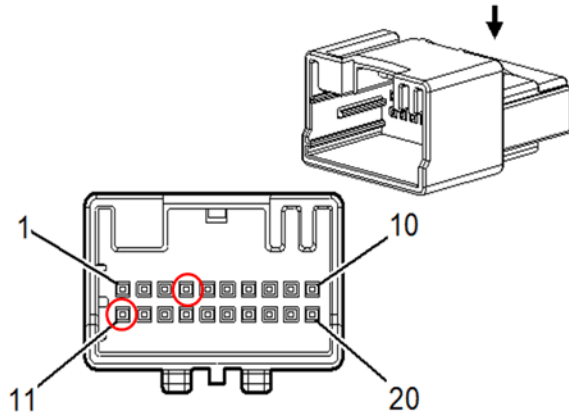

3902207

- 5. Cut circuit 1139 (in cavity 11 of connector), 50mm (2.0 in) above the connector.
- 6. Take the free end of circuit 1139 (still in the harness bundle) and strip off approximately 10mm (0.40 in) of insulation.
- 7. Cut circuit 539 (in cavity 4 of connector), 50mm (2 in) above the connector and strip off approximately 10mm (0.40 in) of insulation from each side

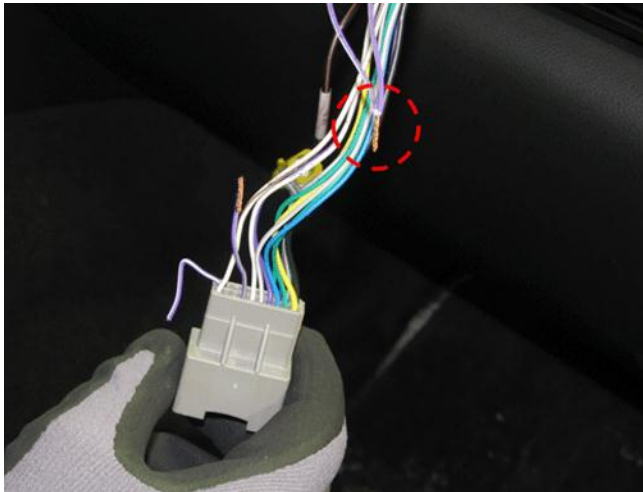

3902210

- 8. Take circuit 1139 and circuit 539 (coming down from the bundle), and twist wrap them together.

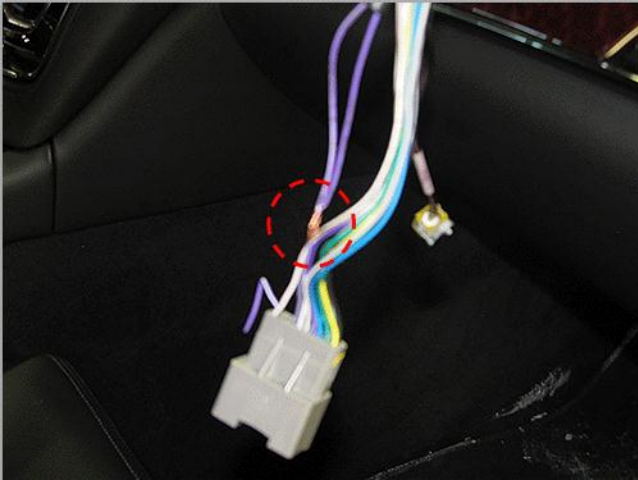

3902213

Note: Only use heat shrink tube, P/N 12355001, or an equivalent flexible adhesive-lined/moisture resistant heat shrink tube to perform the repair in this bulletin

9. Install one 38 mm (1.5 in) section of heat shrink tube onto the wrapped wires, take circuit 539 (coming from the connector) and wrap it together with the two previously wrapped wires.

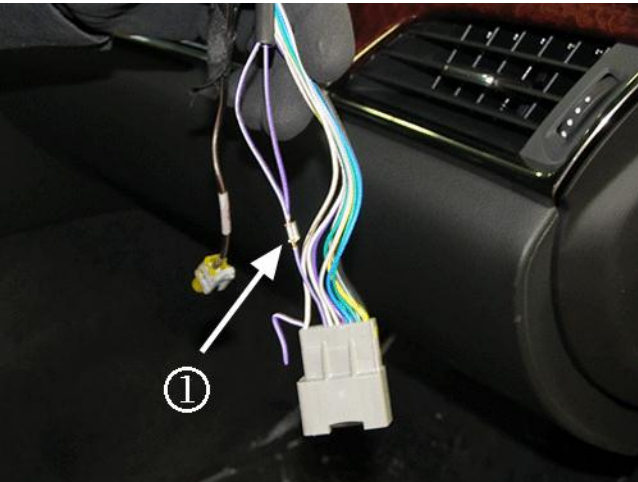

3902214

10. Crimp the splice clip (1) over the three wires using Special Tool J-38125-8, crimp nest F. Verify the crimp quality.

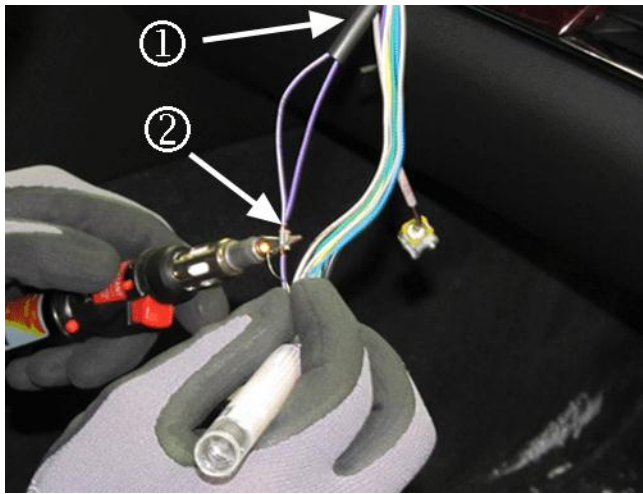

3902217

Warning: DO NOT use soldering equipment that is battery or electric powered. These types of soldering irons can induce voltage into the circuit, which may cause inflator module deployment and/or damage to electrical components. Use only the EL-28125-5 Ultra Torch or another butane fueled soldering iron when working on SIR circuits

Caution: Keep the heat shrink tube (1) above the splice when soldering the splice (2) to ensure that the heat shrink is not prematurely shrunk and closed down over the wire or splice area due to the heat from the soldering iron.

11. Solder the crimp and splice clip using the Ultratorch, part number J-38125-5, or another butane fueled soldering iron.

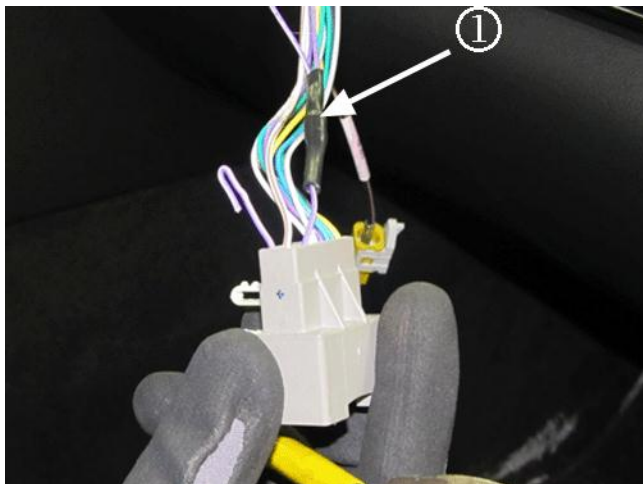

3902218

12. Center the heat shrink tube (1) over the splice and shrink/seal the heat shrink tube securely over the splice crimp and insulated wires.

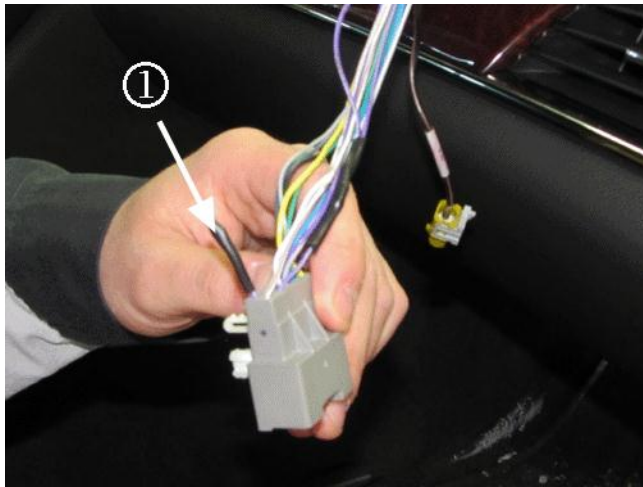

3902219

- 13. Install 1/4" heat shrink tube (1) and shrink the short end of circuit 1139 coming from the connector.



3902221

- 14. Wrap woven polyester electrical tape (PET) or equivalent anti-abrasion tape (1) around the spliced section of the harness wires.
- 15. Reposition the harness to the A-Pillar retainers, reconnect the IP harness and install the connector push pin.



3902224

- 16. In Key-on position, verify the words "Passenger Air Bag" are properly back-lit in the overhead console display.

17. Reinstall the passenger windshield garnish molding. Refer to *Windshield Garnish Molding Replacement* in SI.

FLOOR PLAN REIMBURSEMENT

Dealers in possession of vehicles included in the Stop Delivery are eligible for reimbursement of floor plan expense upon completion of this program. This reimbursement is limited to the number of days from the Stop Delivery message to receipt of the program parts and/or repair procedures. Floor plan reimbursement beyond these dates is not allowed. The amount of reimbursement should be charged as a net amount expense using the program labor operation provided.

COURTESY TRANSPORTATION

The General Motors Courtesy Transportation program is intended to minimize customer inconvenience when a vehicle requires a repair that is covered by the New Vehicle Limited Warranties. The availability of courtesy transportation to customers whose vehicles are within the warranty coverage period and involved in a product program is very important in maintaining customer satisfaction. Dealers are to ensure that these customers understand that shuttle service or some other form of courtesy transportation is available and will be provided at no charge. Dealers should refer to the General Motors Service Policies and Procedures Manual for Courtesy Transportation guidelines.

WARRANTY TRANSACTION INFORMATION

Submit a transaction using the table below. All transactions should be submitted as a ZFAT transaction type, unless noted otherwise.

Note: To avoid having to "H" route the floor plan transaction for approval, it must be submitted prior to the repair transaction.

Labor Code	Description	Labor Time	Net Item
9100607	Headliner Harness Backlight Circuit Wiring Repair	0.7	*
9100618	Floor Plan Reimbursement	N/A	**

* The amount identified in "Net Item" should represent the actual sum total for the PET needed to perform the required repairs, not to exceed \$0.60 USD/CAD.

** The amount identified in "Net Item" should represent the product of the vehicle's average daily interest rate (see table below) multiplied by the actual number of days the vehicle was in dealer inventory and not available for sale. This reimbursement is limited to the number of days from the date of the stop delivery message (April 17, 2014) to the date the repair is completed and the vehicle is ready for sale (not to exceed 50 days):

Vehicle	US Reimbursement Amount
Cadillac CTS	\$ 9.33

CUSTOMER NOTIFICATION

General Motors will notify customers of this program on their vehicle.

DEALER PROGRAM RESPONSIBILITY

All unsold new vehicles in dealers' possession and subject to this program must be held and inspected/repaired per the service procedure of this program bulletin before customers take possession of these vehicles.

Dealers are to service all vehicles subject to this program at no charge to customers, regardless of mileage, age of vehicle, or ownership, from this time forward.

Customers who have recently purchased vehicles sold from your vehicle inventory, and for which there is no customer information indicated on the involved vehicle listing, are to be contacted by the dealer. Arrangements are to be made to make the required correction according to the instructions contained in this bulletin.

In summary, whenever a vehicle subject to this program enters your vehicle inventory, or is in your facility for service in the future, you must take the steps necessary to be sure the program correction has been made before selling or releasing the vehicle.

