



# Recall Bulletin



## F/CMVSS NONCOMPLIANCE RECALL

**SUBJECT:** Passenger Side Instrument Panel Performance

**MODELS:** 2009-2014 Chevrolet Express  
2009-2014 GMC Savana  
1500 Series Equipped with Passenger Side Airbag (AK5))

This bulletin has been revised to include labor codes for fleet repairs and for repairs made with parts shipped from the WPC. A copy of the customer letter has also been added. Please discard all copies of bulletin 14105.

It is a violation of Federal law for a dealer to deliver a new motor vehicle or any new or used item of motor vehicle equipment (including a tire) covered by this notification under a sale or lease until the defect or noncompliance is remedied.

Vehicles involved in this recall were placed on stop delivery March 7 and March 10, 2014.

All involved vehicles that are in dealer inventory must be held and not delivered to customers, dealer traded, or used for demonstration purposes until the repair contained in this bulletin has been performed on the vehicle.

### Important

- **This bulletin addresses the light duty vehicles ONLY (1500 series)**
- The heavy duty vehicles (2500/3500 series) are addressed under bulletin 14082

### CONDITION

General Motors has decided that certain 2009-2014 model year Chevrolet Express and GMC Savana 1500 series vehicles, equipped with front passenger airbags fail to conform to Federal/Canada Motor Vehicle Safety Standard 201, *Occupant Protection in Interior Impact*. On these vehicles, during a frontal impact below the air bag deployment threshold, if an unrestrained front passenger head hits the instrument panel above where the passenger airbag is located, it may decelerate at a rate exceeding the requirements of F/CMVSS 201, resulting in a greater risk of injury.

CORRECTION

Dealers are to install a trim piece on the passenger side instrument panel on all vehicles, and on 2012-2014 model year vehicles, dealers are to also replace the front passenger seat belt retractor.

VEHICLES INVOLVED

All involved vehicles are identified by Vehicle Identification Number on the Investigate Vehicle History screen in GM Global Warranty Management system. Dealership service personnel should always check this site to confirm vehicle involvement prior to beginning any required inspections and/or repairs. It is important to routinely use this tool to verify eligibility because not all similar vehicles may be involved regardless of description or option content.

For dealers with involved vehicles, a listing with involved vehicles containing the complete vehicle identification number, customer name, and address information has been prepared and will be provided to US and Canadian dealers through the GM GlobalConnect Recall Reports, or sent directly to export dealers. Dealers will not have a report available if they have no involved vehicles currently assigned.

The listing may contain customer names and addresses obtained from Motor Vehicle Registration Records. The use of such motor vehicle registration data for any purpose other than follow-up necessary to complete this recall is a violation of law in several states/provinces/countries. Accordingly, you are urged to limit the use of this report to the follow-up necessary to complete this recall.

PART INFORMATION

Parts required to complete this recall are to be obtained from General Motors Customer Care and Aftersales (GMCC&A). Parts are currently in limited supply. If a SPAC case is required, dealers should place a CSO order (not CSO3) and upgrade the order to a SPAC case themselves. **Do not place orders for unsold vehicles in dealer inventory at this time.**

**Note:** For specific large fleets, parts will be preshipped from the Warranty Parts Center (WPC) to identified fleet locations beginning April 25, 2014.

Part Number	Description	Quantity/Vehicle
23226083	TRAY, I/P STOW	1
21077323	RETAINER, PUSH IN	2
19303303	BELT KIT, P/SEAT(RETR SI) (MEDIUM NEUTRAL) (2012-2014 MODEL YEAR ONLY)	1
19303304	BELT KIT, P/SEAT(RETR SI) (MEDIUM DARK PEWTER) (2012-2014 MODEL YEAR ONLY)	1
19303305	BELT KIT,P/SEAT(RETR SI) (ORANGE) (2012-2014 MODEL YEAR ONLY)	1

**SERVICE PROCEDURE – Model Years 2009-2011**

1. Remove the instrument panel upper trim pad. *Refer to Instrument Panel Upper Trim Pad Replacement in SI.*

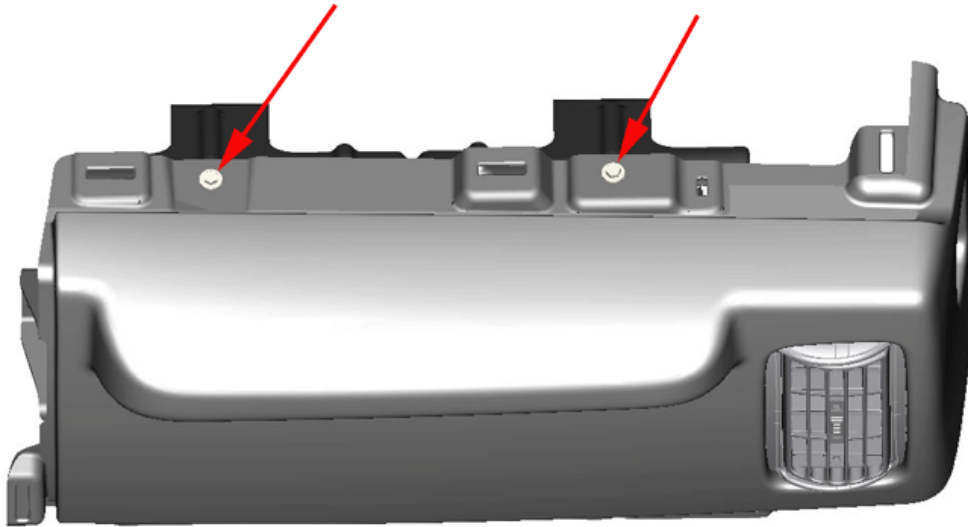

3785217

2. Remove the upper two screws that attach the instrument panel pad to the instrument panel bracket.



3804499

3. Inspect the brow assembly before installation to ensure the energy absorbing material is present.

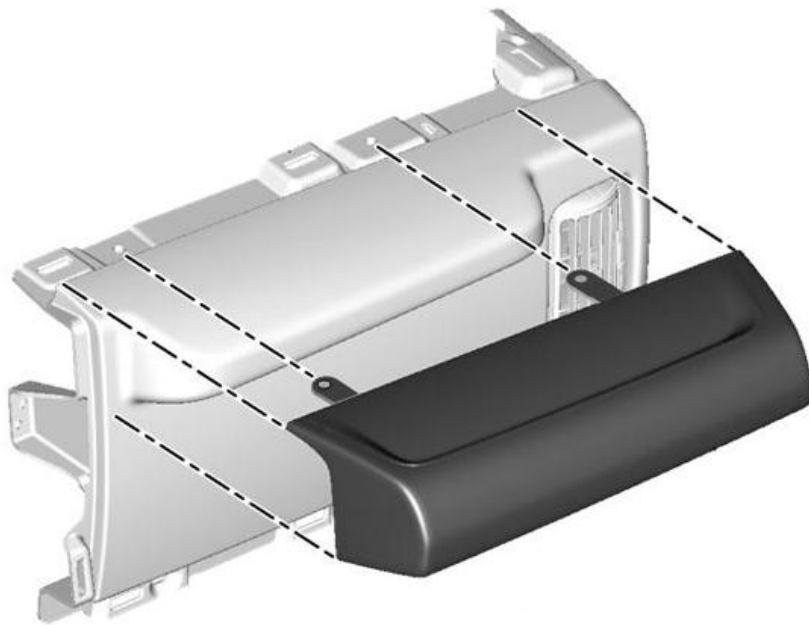

3785223

4. Install the brow assembly to the instrument panel.



3785220

5. Secure the brow assembly to the instrument panel using the two screws that were previously removed. Tighten the screws to 3 N-m (27 lb in).

- Using the brow assembly as the template, drill two holes using an 8 mm (5/16 in) bit. The depth of the hole should be no more than 30 mm (1.25 in) deep.



3785225

- Install the two retainers.
- Install the instrument panel upper trim pad. *Refer to Instrument Panel Upper Trim Pad Replacement in SI.*

**SERVICE PROCEDURE - Model Years 2012-2014**

1. Remove the instrument panel upper trim pad. *Refer to Instrument Panel Upper Trim Pad Replacement in SI.*

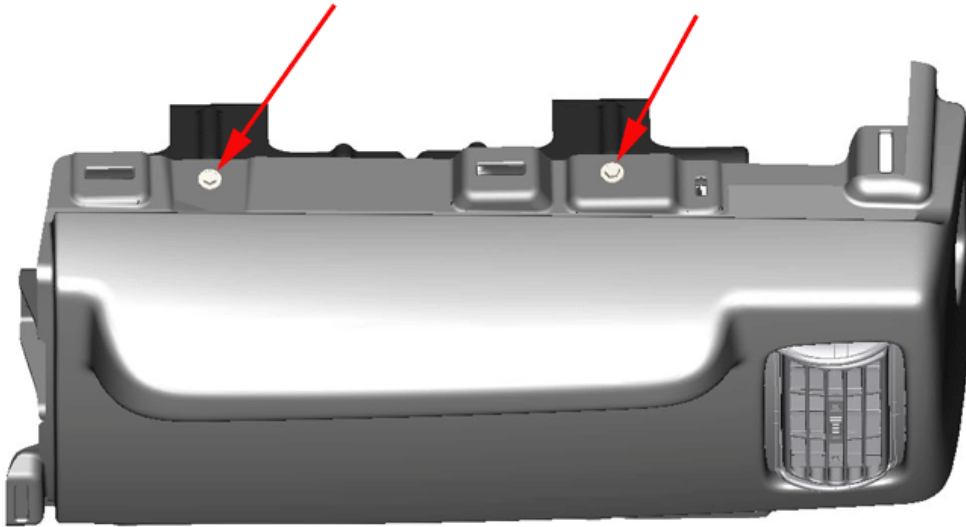

3785217

2. Remove the upper two screws that attach the instrument panel pad to the instrument panel bracket.



3804499

3. Inspect the brow assembly before installation to ensure the energy absorbing material is present.

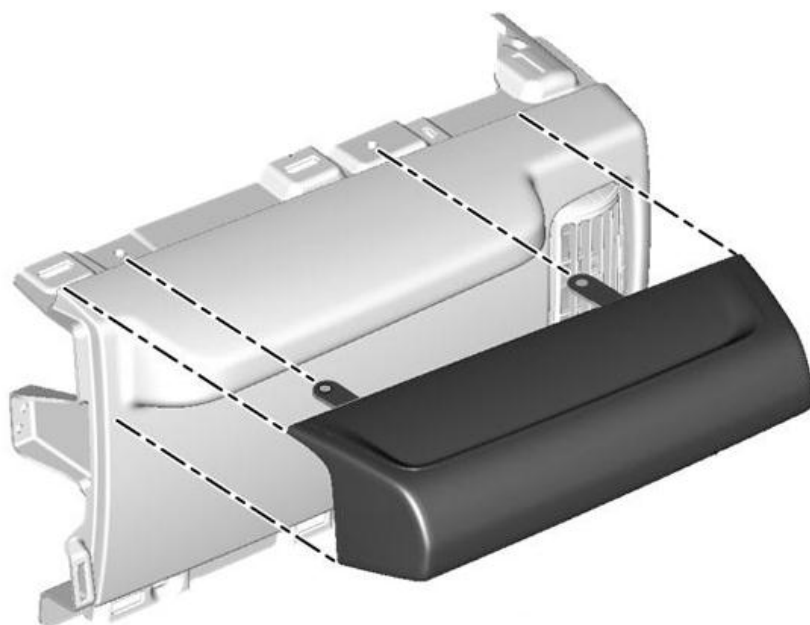

3785223

4. Install the brow assembly to the instrument panel.



3785220

5. Secure the brow assembly to the instrument panel using the two screws that were previously removed. Tighten the screws to 3 N-m (27 lb in).

- Using the brow assembly as the template, drill two holes using an 8 mm (5/16 in) bit. The depth of the hole should be no more than 30 mm (1.25 in) deep.



3785225

- Install the two retainers.
- Install the instrument panel upper trim pad. *Refer to Instrument Panel Upper Trim Pad Replacement in SI.*
- Remove the passenger front seat belt retractor. *Refer to Front Seat Belt Retractor Replacement in SI.*
- Install the passenger front seat belt retractor. *Refer to Front Seat Belt Retractor Replacement in SI.*

#### FLOOR PLAN REIMBURSEMENT

Dealers in possession of vehicles included in the Stop Delivery are eligible for reimbursement of floor plan expense upon completion of this recall. This reimbursement is limited to the number of days from the Stop Delivery message to receipt of the recall parts and/or repair procedures. Floor plan reimbursement beyond these dates is not allowed. The amount of reimbursement should be charged as a net amount expense using the recall labor operation provided.



**WARRANTY TRANSACTION INFORMATION**

Submit a transaction using the table below. All transactions should be submitted as a ZFAT transaction type, unless noted otherwise.

**Note: To avoid having to "H" route the floor plan reimbursement transaction for approval, it must be submitted prior to the repair transaction.**

<b>Labor Code</b>	<b>Description</b>	<b>Labor Time</b>	<b>Net Item</b>
9100436	Instrument Panel Modification (2009-2011 MY)	0.9	N/A
9100507	Instrument Panel Modification & Seat Belt Retractor Replace (2012-2014 MY)	1.3	N/A
9100532	Instrument Panel Modification for Fleet Customer (2009-2011 MY)	0.9	*
9100533	Instrument Panel Modification & Seat Belt Retractor Replace for Fleet Customer (2012-2014 MY)	1.3	*
9100508	Floor Plan Reimbursement (unsold vehicles in dealer inventory only)	N/A	**

\* Dealers that have performed repairs for fleet customers with fleet-provided parts, or who performed the repairs with a part shipped to their dealership from the WPC, are to submit for the applicable Mark-Up or Landed Cost (for Export) in the Net Item field.

\*\* The amount identified in the "Net Item" column should represent the product of the vehicle's average daily interest rate (see table below) multiplied by the actual number of days the vehicle was in dealer inventory and not available for sale. This reimbursement is limited to the number of days from the date of the stop delivery message (March 7, 2014) to the date the repair is completed and the vehicle is ready for sale (not to exceed 57 days):

<b>Vehicle</b>	<b>US Reimbursement Amount</b>	<b>Canadian Reimbursement Amount</b>
2013 Chevrolet Express	\$3.99	\$5.06
2013 GMC Savana	\$4.35	\$5.06
2014 Chevrolet Express	\$4.14	\$5.06
2014 GMC Savana	\$4.13	\$5.06

**CUSTOMER NOTIFICATION** – For US and Canada

General Motors will notify customers of this recall on their vehicle (see copy of customer letter included with this bulletin).

**CUSTOMER NOTIFICATION** – For Export

Letters will be sent to known owners of record located within areas covered by the US National Traffic and Motor Vehicle Safety Act. For owners outside these areas, dealers should notify customers using the attached sample letter.

## DEALER RECALL RESPONSIBILITY – For US and Export (US States, Territories, and Possessions)

It is a violation of Federal law for a dealer to deliver a new motor vehicle or any new or used item of motor vehicle equipment (including a tire) covered by this notification under a sale or lease until the defect or noncompliance is remedied.

The US National Traffic and Motor Vehicle Safety Act provides that each vehicle that is subject to a recall of this type must be adequately repaired within a reasonable time after the customer has tendered it for repair. A failure to repair within sixty days after tender of a vehicle is prima facie evidence of failure to repair within a reasonable time. If the condition is not adequately repaired within a reasonable time, the customer may be entitled to an identical or reasonably equivalent vehicle at no charge or to a refund of the purchase price less a reasonable allowance for depreciation. To avoid having to provide these burdensome remedies, every effort must be made to promptly schedule an appointment with each customer and to repair their vehicle as soon as possible. In the recall notification letters, customers are told how to contact the US National Highway Traffic Safety Administration if the recall is not completed within a reasonable time.

**This bulletin is notice to you that the new motor vehicles included in this recall may not comply with the standard identified above. Under Title 49, Section 30112 of the United States Code, it is illegal for a dealer to sell a new motor vehicle which the dealer knows does not comply with an applicable Federal Motor Vehicle Safety Standard. As a consequence, if you sell any of these motor vehicles without first performing the recall correction, your facility may be subject to a civil penalty for each such sale.**

### DEALER RECALL RESPONSIBILITY - All

All unsold new vehicles in dealer's possession and subject to this recall must be held and inspected/repaired per the service procedure of this recall bulletin before customers take possession of these vehicles.

Dealers are to service all vehicles subject to this recall at no charge to customers, regardless of mileage, age of vehicle, or ownership, from this time forward.

Customers who have recently purchased vehicles sold from your vehicle inventory, and for which there is no customer information indicated on the dealer listing, are to be contacted by the dealer. Arrangements are to be made to make the required correction according to the instructions contained in this bulletin. . A copy of the customer letter is provided in this bulletin for your use in contacting customers. Recall follow-up cards should not be used for this purpose, since the customer may not as yet have received the notification letter.

In summary, whenever a vehicle subject to this recall enters your vehicle inventory, or is in your facility for service in the future, you must take the steps necessary to be sure the recall correction has been made before selling or releasing the vehicle.



May 2014

Dear General Motors Customer:

This notice is sent to you in accordance with the National Traffic and Motor Vehicle Safety Act.

General Motors has decided that certain 2009-2014 model year Chevrolet Express and GMC Savana vehicles, equipped with front passenger airbags, fail to conform to Federal Motor Vehicle Safety Standard 201, *Occupant Protection in Interior Impact*. As a result, GM is conducting a recall. We apologize for this inconvenience. However, we are concerned about your safety and continued satisfaction with our products.

GM is recalling 1500, 2500, and 3500 series vehicles. However, this letter only applies to 1500 series vehicles. The 2500 and 3500 series vehicles are addressed in safety recall 14082.

**I M P O R T A N T**

- This notice applies to your 2009-2014 model year Chevrolet Express and GMC Savana vehicle, **VIN** \_\_\_\_\_.
- Your vehicle is involved in GM recall 14105.
- Schedule an appointment with your GM dealer.
- This service will be performed for you at **no charge**.

**Why is your vehicle being recalled?**

During a frontal impact below the air bag deployment threshold, if the passenger side occupant is unbelted, their head may hit the instrument panel above where the passenger airbag is located. This panel may not sufficiently absorb the impact of the unbelted passenger's head striking the panel, increasing the risk of injury to the passenger.

**What will we do?**

Your GM dealer will install a trim piece on the passenger side instrument panel on all vehicles, and on 2012-2014 model year vehicles, dealers are to also replace the front passenger seat belt retractor. This service will be performed for you at **no charge**. Because of service scheduling requirements, it is likely that your dealer will need your vehicle longer than the actual service correction time of approximately 55 minutes.

**What should you do?**

You should contact your GM dealer to arrange a service appointment as soon as possible.

Ensure that all passengers wear their safety belts at all times.

**Do you have questions?**

If you have questions or concerns that your dealer is unable to resolve, please contact the appropriate Customer Assistance Center at the number listed below.

Division	Number	Text Telephones (TTY)
Chevrolet	1-800-222-1020	1-800-833-2438
GMC	1-800-462-8782	1-888-889-2438
Guam	65-6267-1752	
Puerto Rico – English	1-800-496-9992	
Puerto Rico – Español	1-800-496-9993	
Virgin Islands	1-800-496-9994	

If after contacting your dealer and the Customer Assistance Center, you are still not satisfied we have done our best to remedy this condition without charge and within a reasonable time, you may wish to write the Administrator, National Highway Traffic Safety Administration, 1200 New Jersey Avenue, SE., Washington, DC 20590, or call the toll-free Vehicle Safety Hotline at 1.888.327.4236 (TTY 1.800.424.9153), or go to <http://www.safercar.gov>. The National Highway Traffic Safety Administration Campaign ID Number for this recall is 14V117.

Federal regulation requires that any vehicle lessor receiving this recall notice must forward a copy of this notice to the lessee within ten days.

Jim Moloney  
General Director,  
Customer and Relationship Services

GM Recall #14105