

TECHNICAL BULLETIN
K245 UPS5314-3bNAS1
29 SEP 2014



© Jaguar Land Rover North America, LLC

NOTE: The information in Technical Bulletins is intended for use by trained, professional Technicians with the knowledge, tools, and equipment required to do the job properly and safely. It informs these Technicians of conditions that may occur on some vehicles, or provides information that could assist in proper vehicle service. The procedures should not be performed by 'do-it-yourselfers'. If you are not a Retailer, do not assume that a condition described affects your vehicle. Contact an authorized Jaguar service facility to determine whether this bulletin applies to a specific vehicle.

SECTION: 205-01

Update Prior to Sale: Driveshaft Fixings

AFFECTED VEHICLE RANGE:

XJ Range (X351)

Model Year: 2014
VIN: V71369-V71498

Engine: V6 S/C 3.0L Petrol

MARKETS:

NAS

CONDITION SUMMARY:

Situation: A potential issue has been identified on a number of 2014 model year XJ (X351) vehicles, fitted with the 3.0L V6 supercharged engine only, where the driveshaft fixings may not have been tightened to the correct torque value.

Action: Retailers are required to **HOLD** only affected vehicles that are within your control and refrain from releasing the vehicles for new or used vehicle sale pending completion of the rework action detailed in this Technical Bulletin. Unsold vehicles should have this performed as part of the Pre-Delivery Inspection (PDI) process but **must** have it completed prior to vehicle handover to the customer.

PARTS:



NOTE: * when ordering parts, order only the expected percentage demand of parts identified

DESCRIPTION	PART No. / SUNDRY CODE	QTY. / VALUE	EXPECTED % of VEHICLES REQUIRING PARTS*
Bolt	C2D2087	12	100

SPECIAL TOOLS:

Refer to Workshop Manual / Service Instruction for any required tools

WARRANTY:



NOTE: Check DDW to ensure that a vehicle is affected by this program prior to undertaking any rework action. Repair procedures are under constant review, and therefore times / prices are subject to change; those quoted here must be taken as guidance only. Refer to TOPIx to obtain the latest repair time. At the time of confirming a booking for vehicle repair, ensure that all outstanding Service Actions are identified to ensure the correct parts are available and adequate workshop time is allocated for repairs to be completed at one visit.

Warranty claims must be submitted quoting Program Code '**K245**' together with the relevant Option Code from the table. The SRO and part information listed have been included for information only. The Option Code(s) that allows for the drive in / drive out allowance may only be claimed if the vehicle is brought into the workshop for this action alone to be undertaken.

This program is valid for a limited time only. Warranty claims with a repair date prior to the **16 March 2015** closure date must be submitted for payment within 30 calendar days of completion of the repair.

PROGRAM CODE	OPTION CODE	DESCRIPTION	SRO	TIME (HOURS)	PARTS / SUNDRY CODE	QTY. / VALUE
K245	B	Driveshaft fixings - Renew	47.91.17	1.90	C2D2087	12
K245	C	Driveshaft fixings - Renew Drive in/drive out	47.91.17 10.10.10	1.90 0.10	C2D2087 -	12 -

Normal Warranty policies and procedures apply

SERVICE INSTRUCTION 'A':

Rear Wheel Drive (RWD) Vehicles Only

1. Open the floor console stowage compartment lid.

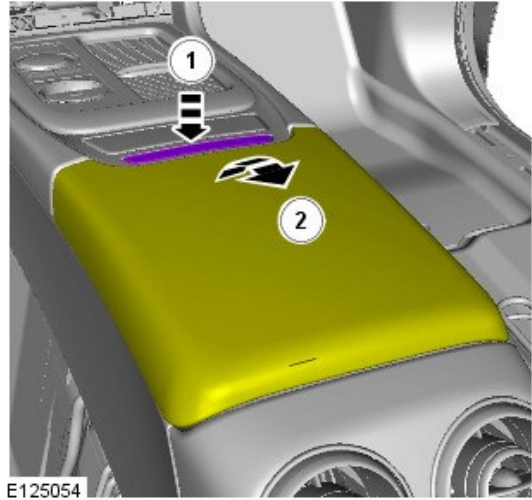

2. Remove the trim.

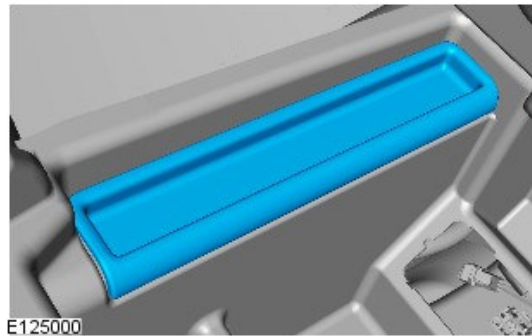

3. Release the emergency park release lever as shown.

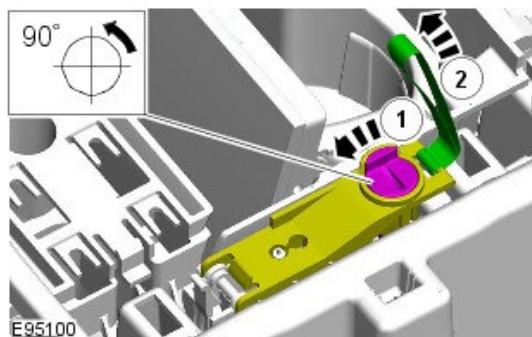

4. Disengage the parking brake.

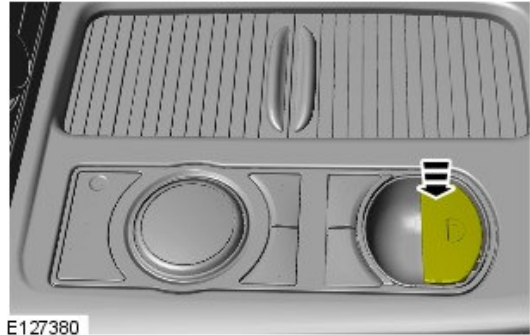

5. Disconnect the battery (see TOPIx Workshop Manual, section 414-01).

6.  **WARNING: Do not work on or under a vehicle supported only by a jack. Always support the vehicle on safety stands.**

Raise and support the vehicle.

7. Remove the exhaust system (see TOPIx Workshop Manual, section 309-00).

8.  **NOTE: Retain the locators for use with the new retaining bolts.**

 **NOTE: Tighten the fixings in sequence directly across/180 degrees (criss-cross).**

Install the six (6) new retaining bolts.

- Torque: 75 Nm

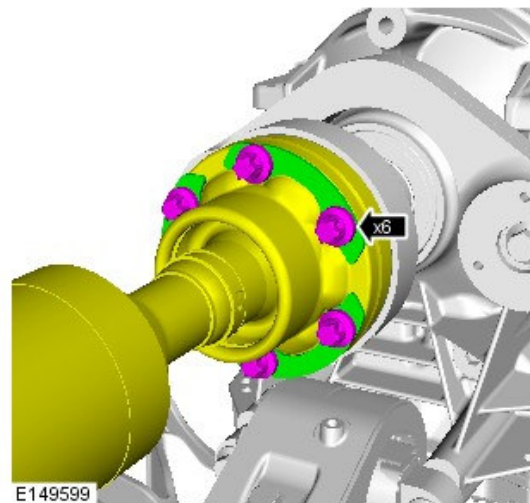

9.  **NOTE: Retain the locators for use with the new retaining bolts.**

 **NOTE: Tighten the fixings in sequence directly across/180 degrees (criss-cross).**

Install the six (6) new retaining bolts.

- Torque: 75 Nm

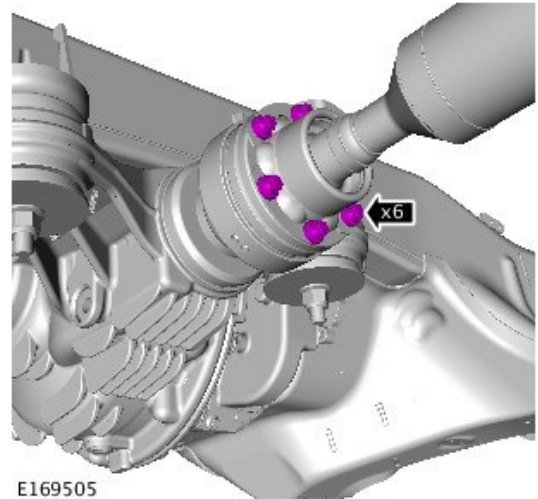

10. Reverse steps 1-7.

SERVICE INSTRUCTION 'B'

All Wheel Drive (AWD) Vehicles Only

1. Disconnect the battery (see TOPIx Workshop Manual, section 414-01).

2.  **WARNING: Do not work on or under a vehicle supported only by a jack. Always support the vehicle on safety stands.**

Raise and support the vehicle.

3. Remove the exhaust system (see TOPIx Workshop Manual, section 309-00).

4. Remove the retaining bolts and release the emergency park release lever cable.

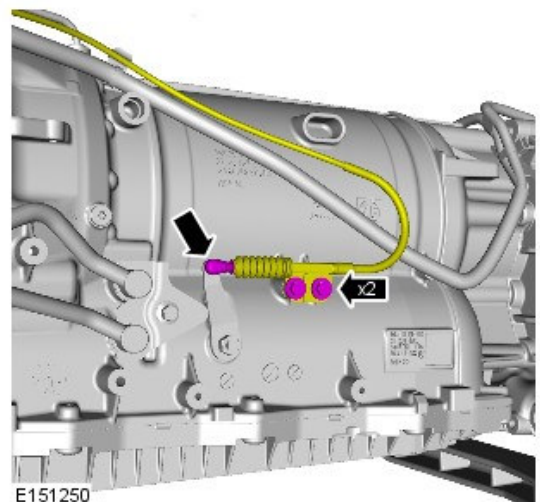

5. Release the emergency park release lever.

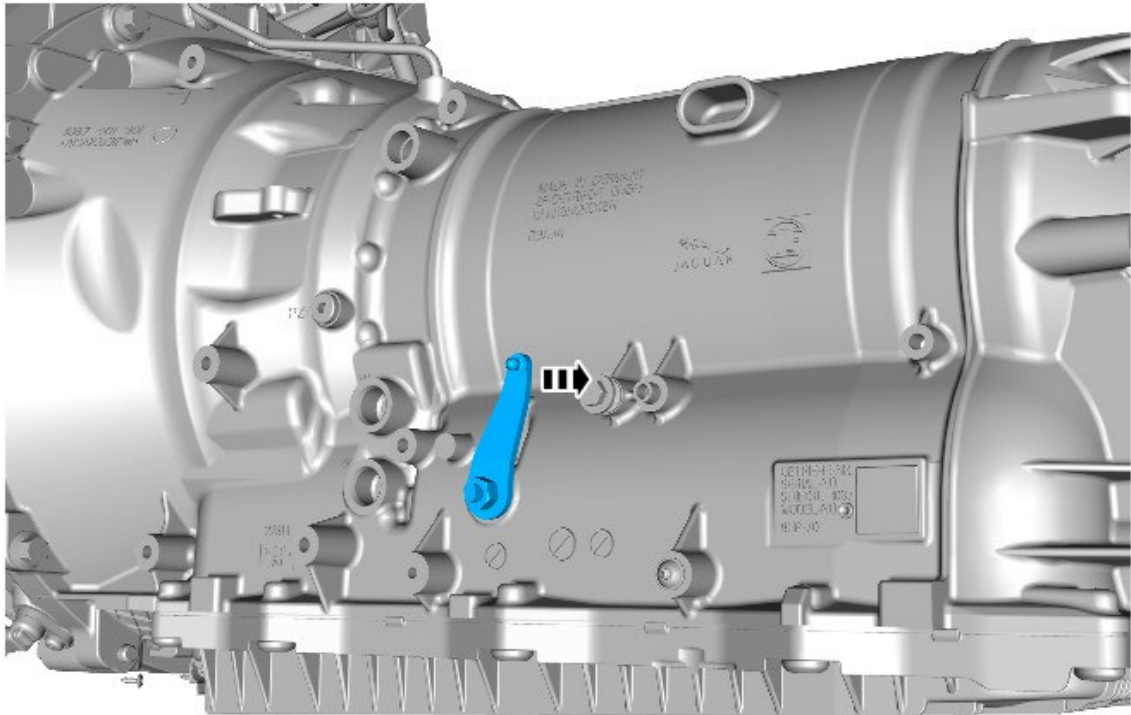

E 152566

6.  **NOTE: Retain the locators for use with the new retaining bolts.**

 **NOTE: Rear Wheel Drive (RWD) shown; All Wheel Drive (AWD) similar.**

 **NOTE: Tighten the fixings in sequence directly across/180 degrees (criss-cross).**

Install the six (6) new retaining bolts.

- Torque: 75 Nm

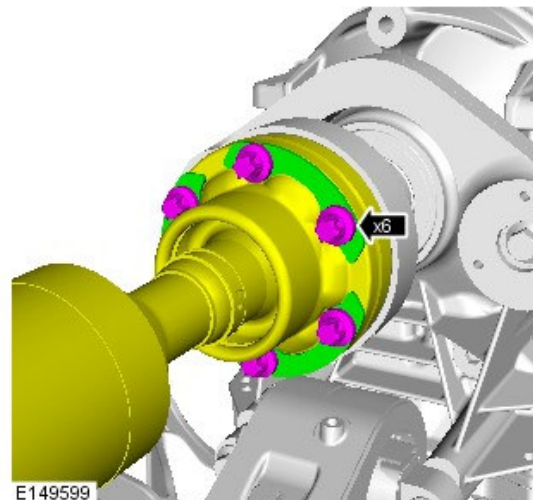

E 149599

7.  **NOTE: Retain the locators for use with the new retaining bolts.**

 **NOTE: Tighten the fixings in sequence directly across/180**

degrees (criss-cross).

Install the six (6) new retaining bolts.

- Torque: 75 Nm

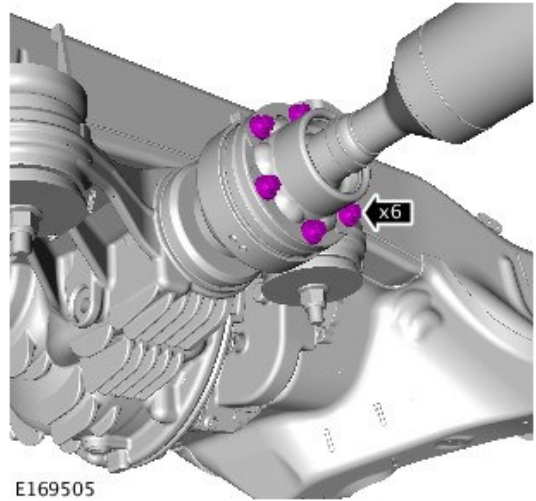

8. Reverse steps 1-5.