

TECHNICAL BULLETIN
K214 UPS0114-3bNAS1
11 APR 2014



© Jaguar Land Rover North America, LLC

NOTE: The information in Technical Bulletins is intended for use by trained, professional Technicians with the knowledge, tools, and equipment required to do the job properly and safely. It informs these Technicians of conditions that may occur on some vehicles, or provides information that could assist in proper vehicle service. The procedures should not be performed by 'do-it-yourselfers'. If you are not a Retailer, do not assume that a condition described affects your vehicle. Contact an authorized Jaguar service facility to determine whether this bulletin applies to a specific vehicle.

SECTION: 501-08

Update Prior to Sale: Door Sill Applique

AFFECTED VEHICLE RANGE:

F-TYPE (X152)

Model Year: 2014
VIN: K00001-K08070

MARKETS:

NAS

CONDITION SUMMARY:

Situation: A potential issue has been identified on 2014 model year F-TYPE (X152) vehicles within the listed VIN range where paint is not adhering to the rear panels and that the paint is peeling where the sill meets the rear quarter.

Action: Retailers are required to **HOLD** all affected vehicles within the listed VIN range that are in their control and refrain from releasing the vehicles for new or used vehicle sale pending completion of the rework action detailed in this Technical Bulletin. Unsold vehicles should have this performed as part of the Pre-Delivery Inspection (PDI) process but must have it completed prior to vehicle handover to the customer.

PARTS:



NOTE: Nitto EPT sealer EE-1010 3mm foam pad to be sourced from the Squeaks & Rattle kit; refer to Technical Bulletin JTB00231NAS and Service Bulletin 1-248NAS for more information and how to replenish the items in the Squeaks & Rattles Kit when necessary.

DESCRIPTION	PART No. / SUNDRY CODE	QTY. / VALUE	EXPECTED % of VEHICLES REQUIRING PARTS*
Cable Tie	XR818697	2	100
Mounting Bracket - Right-Side	T2R3970	1	10
Mounting Bracket - Left-Side	T2R3971	1	10
Body Side Moulding - Right-Side	T2R10391	1	10
Body Side Moulding - Left-Side	T2R10392	1	10
Foam Pad**	ZZZ001	\$1.00	100
Paint and lacquer***	ZZZ666	\$78.00	10

 **NOTE: * when ordering parts, order only the expected percentage demand of parts identified**

 **NOTE: ** an allowance equivalent of approximately \$1.00 (£0.60) has been provided to cover the cost of two (2) foam pads; claim using Sundry Code 'ZZZ001'.**

 **NOTE: *** an allowance equivalent of approximately \$78.00 (£47.00) has been provided to cover the cost of paint and lacquer; claim using Sundry Code 'ZZZ666'.**

SPECIAL TOOLS:

Refer to Workshop Manual / Service Instruction for any required tools

WARRANTY:

 **NOTE: Consumable cost of \$1.00 to be claimed as 'ZZZ001'.**

 **NOTE: Consumable cost of \$78.00 to be claimed as 'ZZZ666'. Dealers are NOT permitted to claim any additional allowance under ZZZ661 for this campaign.**

 **NOTE: Check DDW to ensure that the vehicle is affected by this program prior to undertaking any rework action. Repair procedures are under constant review, and therefore times / prices are subject to change; those quoted here must be taken as guidance only. Refer to TOPIX to obtain the latest repair time. At the time of confirming a booking for vehicle repair, ensure that all outstanding Service Actions are identified to ensure the correct parts are available and adequate workshop time is allocated for repairs to be completed at one visit.**

Warranty claims must be submitted quoting Program Code '**K214**', Option Code '**X**', and the relevant parts and labor. The drive in / drive out allowance may only be claimed if the vehicle is brought into the workshop for this action alone to be undertaken.

This program is valid for a limited time only. Warranty claims with a repair date prior to the **7 August 2014** closure date must be submitted for payment within 30 calendar days of completion of the repair.

DESCRIPTION	SRO	TIME (HOURS)
Remove, inspect rocker panels both sides, modify brackets	76.96.22	1.7
Remove, inspect rocker panels both sides, modify bracket 1 side, replace and modify bracket 1 side	76.96.22	1.7
Remove, inspect rocker panels both sides, replace both brackets and modify	76.96.22	1.7
Remove/replace rocker panel, modify bracket, re-spray - one side	76.96.23	2.3
Remove, inspect rocker panels both sides, modify bracket both sides, respray rocker panels both sides	76.96.23	2.3
Remove, inspect rocker panels both sides, modify bracket 1 side, replace and modify bracket 1 side, respray rocker panel 1 side	76.96.23	2.3
Remove, inspect rocker panels both sides, modify bracket 1 side, replace and modify bracket 1 side, respray rocker panels both sides	76.96.23	2.3
Remove, inspect rocker panels both sides, replace and modify bracket both sides,	76.96.23	2.3

respray rocker panel 1 side		
Remove, inspect rocker panels both sides, replace and modify bracket both sides, respray rocker panels both sides	76.96.23	2.3
Remove, inspect rocker panels both sides, modify bracket both sides, respray rocker panel 1 side, replace rocker panel 1 side	76.96.24	3.7
Remove, inspect rocker panels both sides, modify bracket 1 side, replace and modify bracket 1 side, respray rocker panel 1 side, replace rocker panel 1 side	76.96.24	3.7
Remove, inspect rocker panels both sides, replace and modify bracket both sides, respray rocker panel 1 side, replace rocker panel 1 side	76.96.24	3.7
Remove, inspect rocker panels both sides, replace and modify bracket both sides, replace rocker panel both sides	76.96.25	4.4
Drive in/drive out	10.10.10	0.1

 **NOTE: Normal Warranty policies and procedures apply**

SERVICE INSTRUCTION:

-  **NOTE: Right side shown; left side similar.**

Identify the area of damage.

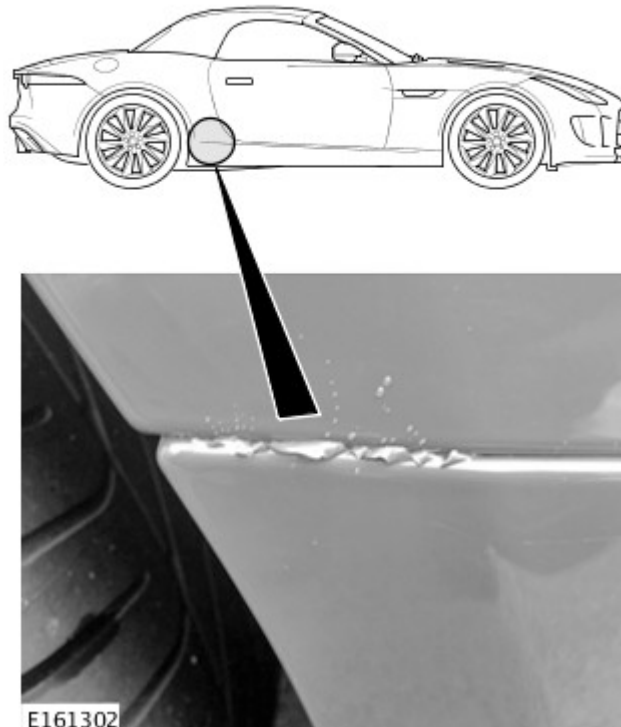

- Remove the rocker panel moulding (see TOPIX Workshop Manual, Section 501-08).

3. Repair and paint the damaged area on the rocker sill moulding.

4. Remove the three (3) mounting bracket bolts.



5. Remove the rocker panel moulding bracket.



6. Using a suitable drill, drill out an 8mm hole in the rocker panel mounting bracket

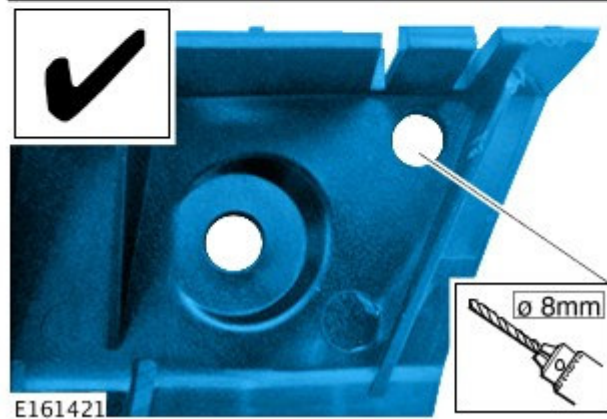
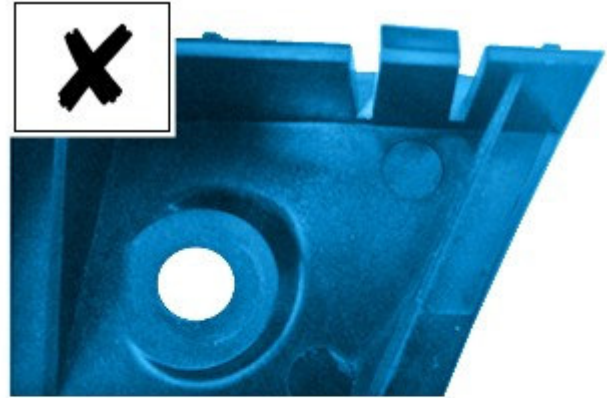

7.  **NOTE: Repeat this procedure for both sides.**

Cut the Nitto EPT sealer EE - 1010 3mm foam pad (from the Squeaks & Rattles kit) to 25mm in length.

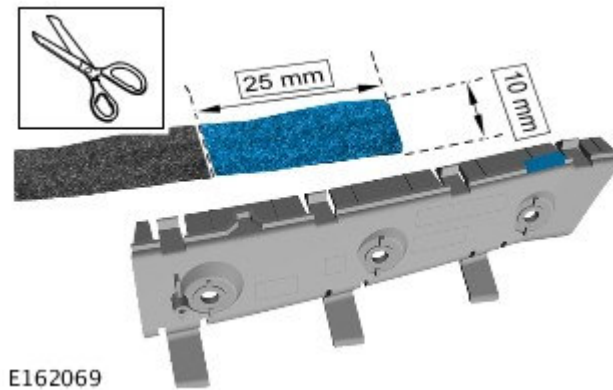

8.  **NOTE: Repeat this procedure on both side brackets.**

 **NOTE: The foam pad goes over the**

lip/rib on the bracket and not just parallel to the lip/rib.

Install the foam pad.

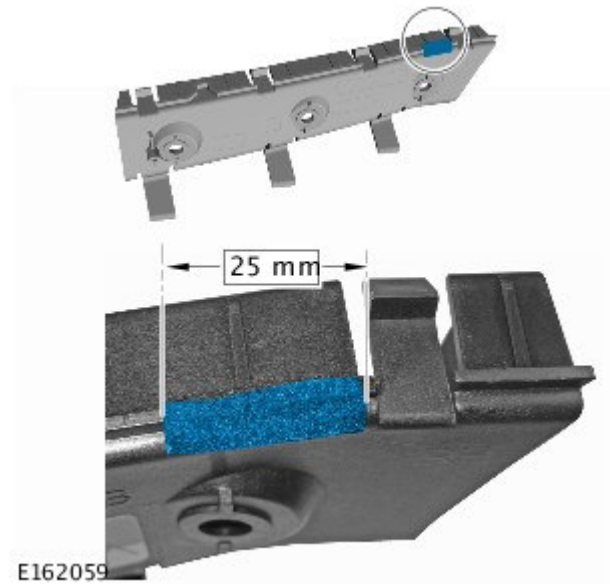

9. Install the rocker panel mounting bracket.

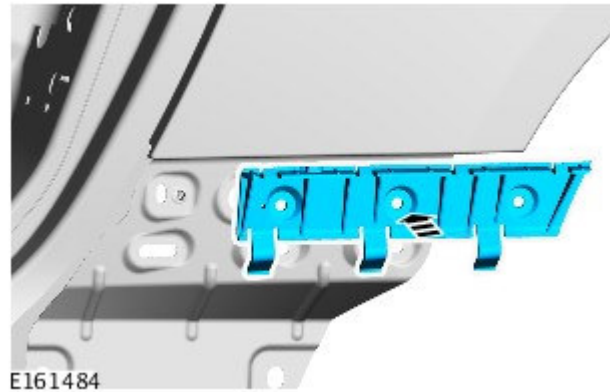

10.  **CAUTION: Make sure no damage is caused to the vehicle or bracket.**

Push the bracket down when installing the three bolts.

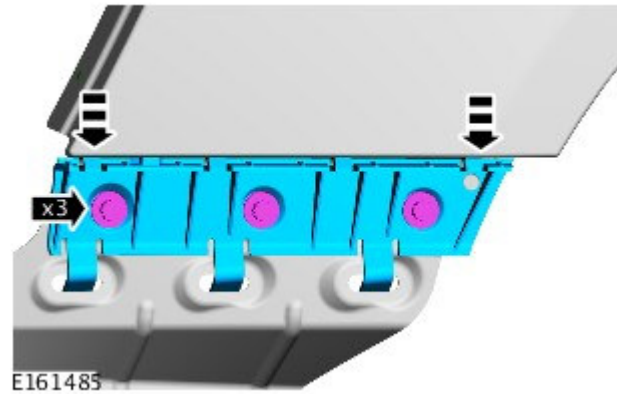

11. Install the rocker panel moulding (see TOPIx Workshop Manual, Section 501-08).

12. Insert a cable tie through the rocker panel location hole and the 8mm hole drilled through the location bracket.



13. Locate the rocker panel moulding onto the location bracket and pull the cable tie tight.

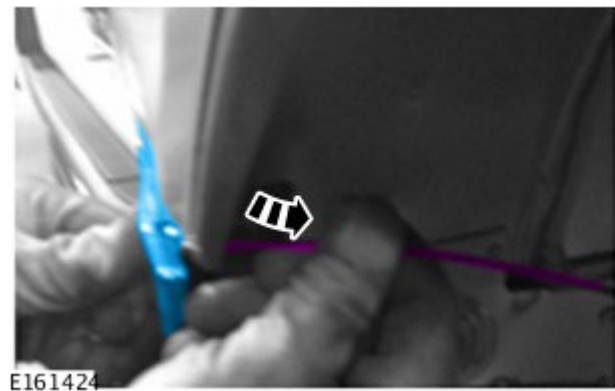

- 14.** Use a suitable tool to remove any excess cable tie.

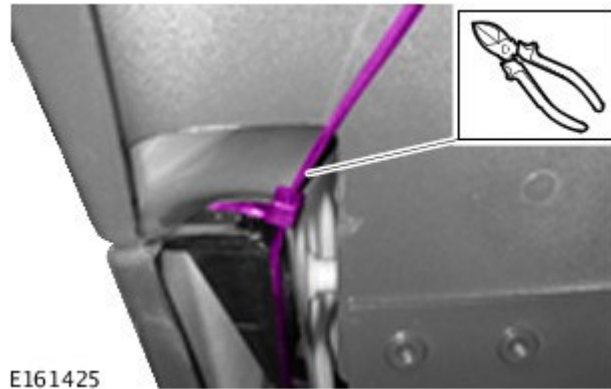

- 15.** Visual inspection of the fitted cable tie

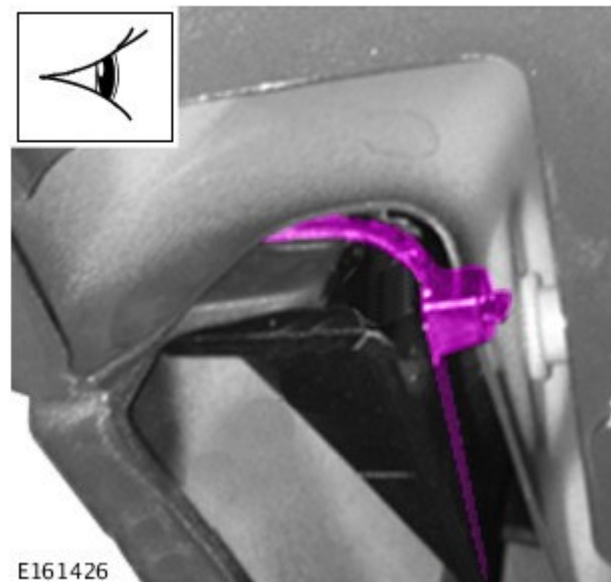

- 16.** Finish the Installation of the rocker panel moulding (see TOPIx Workshop Manual, Section 501-08).