

# Tire Pressure Warning System Activation & Initialization

Service Category General

Section Pre-Delivery Service

Market USA

Lexus Supports  
ASE Certification 

## Applicability

YEAR(S)	MODEL(S)	ADDITIONAL INFORMATION
2015	RX350, RX450H	

## Introduction

2015 model year RX 350 and RX 450h vehicles are equipped with a direct-type Tire Pressure Warning System (TPWS). Each tire (except the spare tire) has a tire pressure warning valve/sensor that measures tire pressure data. The data is transmitted to the Tire Pressure Warning System antenna/receiver and then to the Tire Pressure Warning System ECU.

During Pre-Delivery Service (PDS), the tire pressure warning valves/sensors must be **activated** for Japan-built vehicles by following the activation procedure in this bulletin. NAP-built vehicles do NOT require activation, but both Japan-built (VINs start with "J") and NAP-built (VINs start with "2") vehicles require the TPWS to be **initialized** by following the initialization procedure in this bulletin.

## Required Tools & Equipment

REQUIRED EQUIPMENT	SUPPLIER	PART NUMBER	QTY
Techstream 2.0*	ADE	TS2UNIT	1
TIS Techstream		TSPKG1	
Techstream Lite		TSLITEDLR01	

\* Essential SST.

### NOTE

- Only ONE of the Techstream units listed above is required.
- Software version 9.00.025 or later is required.
- Additional Techstream units may be ordered by calling Approved Dealer Equipment (ADE) at 1-800-368-6787.

## Warranty Information

OP CODE	DESCRIPTION	TIME	OFF	T1	T2
N/A	Not Applicable to Warranty	–	–	–	–

## Tire Pressure Warning System Activation & Initialization

### Reference

- After cycling the ignition to the "IG-ON" position, the Low Tire Pressure Warning Light will blink until all the tire pressure warning valves/sensors are activated.
- The Diagnostic Trouble Codes (DTCs) listed below may be stored in the TPWS ECU until the tire pressure warning valves/sensors are activated.
- The DTCs will automatically clear when the tire pressure warning valves/sensors are activated.

Figure 1.

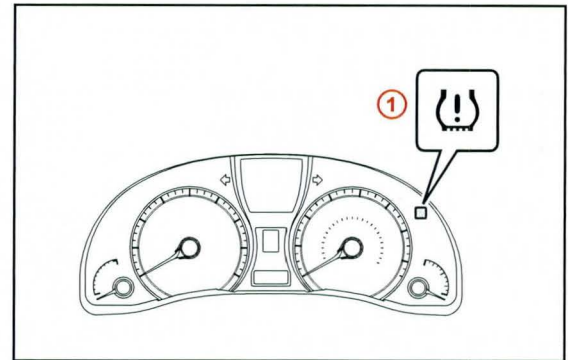

<b>1</b>	<b>Low Tire Pressure Warning Light</b>
----------	--

DTC NO. *1	DTC NO. *2	DTC EXPLANATION
11	C2111	Transmitter ID1 Operation Stop (Sleep Mode)
12	C2112	Transmitter ID2 Operation Stop (Sleep Mode)
13	C2113	Transmitter ID3 Operation Stop (Sleep Mode)
14	C2114	Transmitter ID4 Operation Stop (Sleep Mode)

\*1 : DTC No. indicated by blinking of the Low Tire Pressure Warning Light.

\*2 : DTC No. indicated on Techstream.

## Tire Pressure Warning System Activation & Initialization

### Activation Procedure

**NOTE**

**ONLY** perform the following activation procedure on Japan-built vehicles.

1. Connect Techstream.
2. Cycle the ignition switch to the "IG-ON" position and check that the Low Tire Pressure Warning Light blinks.

Figure 2.

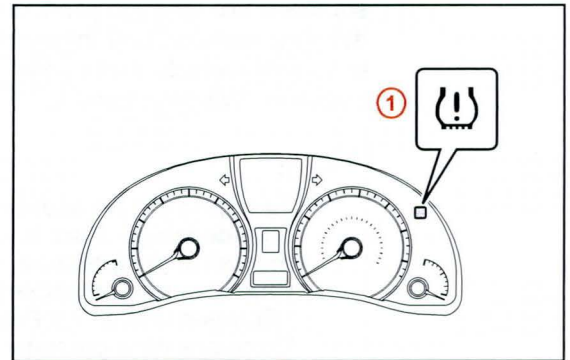

1 Low Tire Pressure Warning Light

3. Press or remove the valve core to reduce the tire inflation pressure rapidly by 6 psi (0.4 kgf/cm<sup>2</sup>, 40 kPa), or more, within 30 seconds.

If the tire inflation pressure is NOT reduced by 6 psi (0.4 kgf/cm<sup>2</sup>, 40 kPa), or more, within 30 seconds, the tire pressure warning valves/sensors will NOT be activated.

**NOTE**

**This operation is required for the system to be activated and MUST be performed for each tire (except the spare tire) one at a time.**

Figure 3.

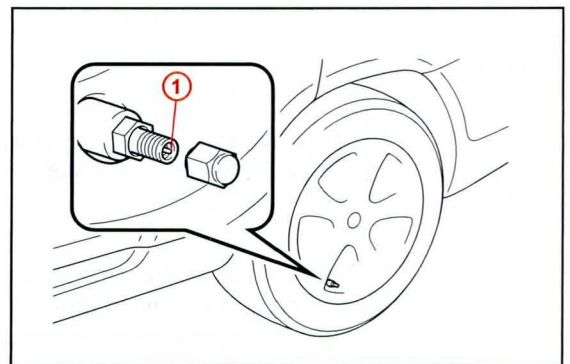

1 Core

4. Check that the Low Tire Pressure Warning Light goes OFF after all the tire pressure warning valves/sensors are activated.
5. Using Techstream, check for TPWS DTCs.
  - If NO DTCs are stored, go to step 1 of the Initialization Procedure.
  - If DTCs C2111 – C2114 are stored, repeat step 3.
  - If any other DTCs are stored, refer to the Repair Manual.

## Tire Pressure Warning System Activation & Initialization

### Initialization Procedure

**NOTE**

Perform the following initialization procedure for BOTH NAP-built and Japan-built vehicles.

1. Cycle the ignition switch to the "IG-ON" position and connect Techstream.
2. Adjust all tires (except the spare tire) to the standard tire inflation pressure, as indicated on the Tire and Loading Information label located inside the vehicle and confirm that the Low Tire Pressure Warning Light is OFF.

**NOTE**

- To adjust tire pressure correctly when outside temperature is significantly colder than shop temperature, perform a Health Check using Techstream and select the "Compensation Tire Pressure" checkbox. Compensation pressures will be displayed on the Health Check results screen.
- Adjust the tire pressure when the tires are cold.

**NAP-BUILT VEHICLES:**

Remove the ID number labels that are attached to each wheel and place the labels in the glove box.

3. Push and hold the Tire Pressure Warning "SET" Switch for 3 seconds until the Low Tire Pressure Warning Light blinks 3 times and then turns OFF to set the tire pressure initialization.

Figure 4.

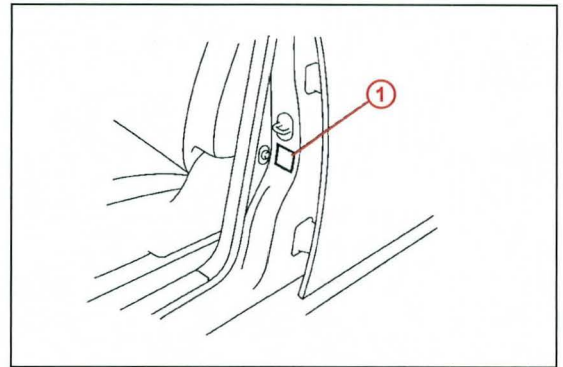

1 Tire and Loading Information Label

Figure 5.

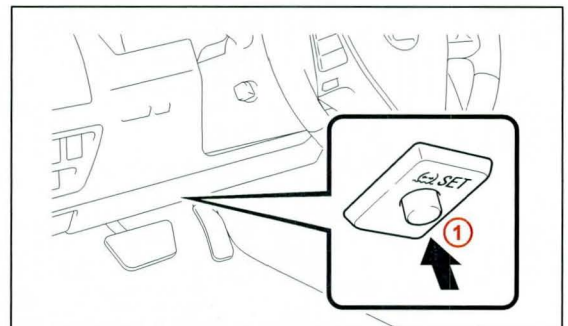

1 Tire Pressure Warning "SET" Switch

## Tire Pressure Warning System Activation & Initialization

---

### Initialization Procedure (Continued)

4. Cycle the ignition switch to the "OFF" position and then to the "IG-ON" position.

**NOTE**

It is necessary for the ignition to be in the "IG-ON" mode at **LEAST 5 minutes** for initialization to complete correctly.

5. Check the tire pressure values of all the tires using Techstream.

**NOTE**

- It can take 2 – 3 minutes for the tire pressure values to be displayed on the Techstream Data List.
- If the tire pressure values **CANNOT** be displayed on the Techstream screen, the initialization is **NOT** completed. Repeat steps 2 – 4.